

2021



SERVICE MANUAL

**CRF300L/LA
CRF300LR/LRA**

1. GENERAL INFORMATION

A Few Words About Safety	1-2	SPECIAL TOOL LIST	1-21
How To Use This Manual	1-3	CABLE & HARNESS ROUTING	1-22
MODEL IDENTIFICATION	1-5	EMISSION CONTROL SYSTEMS	1-65
SPECIFICATIONS	1-8	MAINTENANCE SCHEDULE	1-68
TORQUE VALUE	1-16		





A Few Words About Safety

Service Information

The service and repair information contained in this manual is intended for use by qualified, professional technicians.

Attempting service or repairs without the proper training, tools, and equipment could cause injury to you or others. It could also damage the vehicle or create an unsafe condition.

This manual describes the proper methods and procedures for performing service, maintenance and repairs. Some procedures require the use of specially designed tools and dedicated equipment. Any person who intends to use a replacement part, service procedure or a tool that is not recommended by Honda, must determine the risks to their personal safety and the safe operation of the vehicle.

If you need to replace a part, use genuine Honda parts with the correct part number or an equivalent part. We strongly recommend that you do not use replacement parts of inferior quality.

For Your Customer's Safety

Proper service and maintenance are essential to the customer's safety and the reliability of the vehicle. Any error or oversight while servicing a vehicle can result in faulty operation, damage to the vehicle, or injury to others.

⚠ WARNING

Improper service or repairs can create an unsafe condition that can cause your customer to be seriously hurt or killed.

Follow the procedures and precautions in this manual and other service materials carefully.

For Your Safety

Because this manual is intended for the professional service technician, we do not provide warnings about many basic shop safety practices (e.g., Hot parts—wear gloves). If you have not received shop safety training or do not feel confident about your knowledge of safe servicing practice, we recommended that you do not attempt to perform the procedures described in this manual.

Some of the most important general service safety precautions are given below. However, we cannot warn you of every conceivable hazard that can arise in performing service and repair procedures. Only you can decide whether or not you should perform a given task.

⚠ WARNING

Failure to properly follow instructions and precautions can cause you to be seriously hurt or killed.

Follow the procedures and precautions in this manual carefully.

Important Safety Precautions

Make sure you have a clear understanding of all basic shop safety practices and that you are wearing appropriate clothing and using safety equipment. When performing any service task, be especially careful of the following:

- Read all of the instructions before you begin, and make sure you have the tools, the replacement or repair parts, and the skills required to perform the tasks safely and completely.
- Protect your eyes by using proper safety glasses, goggles or face shields any time you hammer, drill, grind, pry or work around pressurized air or liquids, and springs or other stored-energy components. If there is any doubt, put on eye protection.
- Use other protective wear when necessary, for example gloves or safety shoes. Handling hot or sharp parts can cause severe burns or cuts. Before you grab something that looks like it can hurt you, stop and put on gloves.
- Protect yourself and others whenever you have the vehicle up in the air. Any time you lift the vehicle, either with a hoist or a jack, make sure that it is always securely supported. Use jack stands.

Make sure the engine is off before you begin any servicing procedures, unless the instruction tells you to do otherwise. This will help eliminate several potential hazards:

- Carbon monoxide poisoning from engine exhaust. Be sure there is adequate ventilation whenever you run the engine.
- Burns from hot parts or coolant. Let the engine and exhaust system cool before working in those areas.
- Injury from moving parts. If the instruction tells you to run the engine, be sure your hands, fingers and clothing are out of the way.

Gasoline vapors and hydrogen gases from batteries are explosive. To reduce the possibility of a fire or explosion, be careful when working around gasoline or batteries.

- Use only a nonflammable solvent, not gasoline, to clean parts.
- Never drain or store gasoline in an open container.
- Keep all cigarettes, sparks and flames away from the battery and all fuel-related parts.



How To Use This Manual

This manual is "Spec (Specific)" Service Manual. The service and repair information for this model is described in this manual as specific information. Refer to "Basic" Service Manual for basic/common service information and instructions.

Follow the Maintenance Schedule recommendations to ensure that the vehicle is in peak operating condition. Performing the first scheduled maintenance is very important. It compensates for the initial wear that occurs during the break-in period.

Find the section you want on this page, then turn to the table of contents on the first page of the section.

Your safety, and the safety of others, is very important. To help you make informed decisions we have provided safety messages and other information throughout this manual. Of course, it is not practical or possible to warn you about all the hazards associated with servicing this vehicle.

You must use your own good judgement.

You will find important safety information in a variety of forms including:

- Safety Labels – on the vehicle
- Safety Messages – preceded by a safety alert symbol  and one of three signal words, DANGER, WARNING, or CAUTION. These signal words mean:

 DANGER You WILL be KILLED or SERIOUSLY HURT if you don't follow instructions.

 WARNING You CAN be KILLED or SERIOUSLY HURT if you don't follow instructions.

 CAUTION You CAN be HURT if you don't follow instructions.

- Instructions – how to service this vehicle correctly and safely.

As you read this manual, you will find information that is preceded by a **NOTICE** symbol. The purpose of this message is to help prevent damage to your vehicle, other property, or the environment.

ALL INFORMATION, ILLUSTRATIONS, DIRECTIONS AND SPECIFICATIONS INCLUDED IN THIS PUBLICATION ARE BASED ON THE LATEST PRODUCT INFORMATION AVAILABLE AT THE TIME OF APPROVAL FOR PRINTING. Honda Motor Co., Ltd. RESERVES THE RIGHT TO MAKE CHANGES AT ANY TIME WITHOUT NOTICE AND WITHOUT INCURRING ANY OBLIGATION WHATSOEVER. NO PART OF THIS PUBLICATION MAY BE REPRODUCED WITHOUT WRITTEN PERMISSION. THIS MANUAL IS WRITTEN FOR PERSONS WHO HAVE ACQUIRED BASIC KNOWLEDGE OF MAINTENANCE ON Honda MOTORCYCLES, MOTOR SCOOTERS OR ATVS.

© Honda Motor Co., Ltd.
SERVICE PUBLICATION OFFICE

Date of Issue: January, 2021



















GENERAL INFORMATION







SYMBOLS

The symbols used throughout this manual show specific service procedures. If supplementary information is required pertaining to these symbols, it would be explained specifically in the text without the use of the symbols.

INSTRUCTION SYMBOL

	Removal or Disassembly procedure. Disconnect the connector.		Installation or Assembly procedure. Connect the connector.
	Order of removal/disassembly with a point of note.		Order of installation/assembly with a point of note.
	Tighten specified torque.		Replace with a new one before assembly.
	Check the part for an inspection.		Measure the part for an inspection.
	Turn ignition switch to OFF.		Turn ignition switch to ON.
	Start the engine.		Measure a resistance or check continuity.
	Measure a voltage.		Measure an ampere.
	Use the Honda special tool.		Refer to "Basic" Service Manual for the instruction.

LUBRICATION AND SEAL SYMBOL

	Use the recommend engine oil.		Apply molybdenum oil solution (mixture of an engine oil and molybdenum grease in a ration of 1:1).
	Apply a specified grease. Use a multi-purpose grease unless otherwise specified.		Apply a liquid sealant.
	Apply a locking agent. Use a medium strength one unless otherwise specified.		Use DOT 4 brake fluid.
	Use a specified fork oil or suspension fluid.		



MODEL IDENTIFICATION

- Model name: CRF300LR/LRA/L/LA

DESTINATION CODES

Throughout this manual, the following codes are used to identify individual types for each region.

DESTINATION CODE	REGION
AC	USA 50 state (meet California)
CM	Canada

TYPES and MODELS

Type	Model	Destination code	Anti-lock Brake System	EVAP canister	LED headlight
Rally	CRF300LR	AC	–	0	0
		CM	–	–	0
	CRF300LRA	AC	0	0	0
		CM	0	–	0
Standard	CRF300L	AC	–	0	–
		CM	–	–	–
	CRF300LA	AC	0	0	–
		CM	0	–	–



GENERAL INFORMATION

Rally type

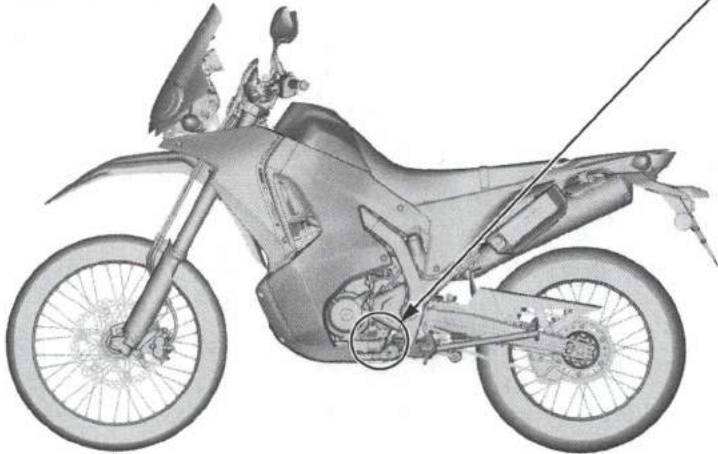
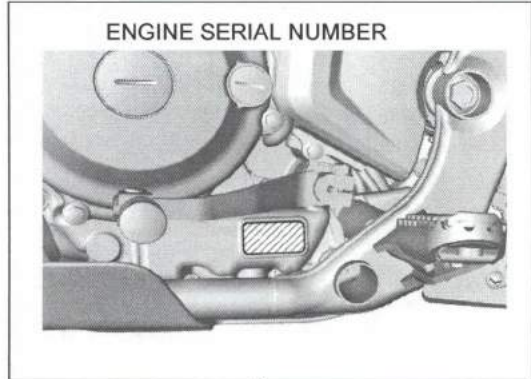
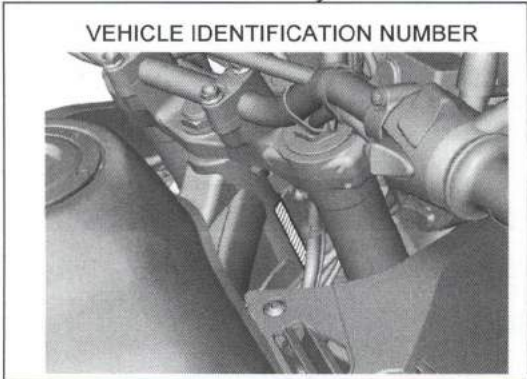



Standard type

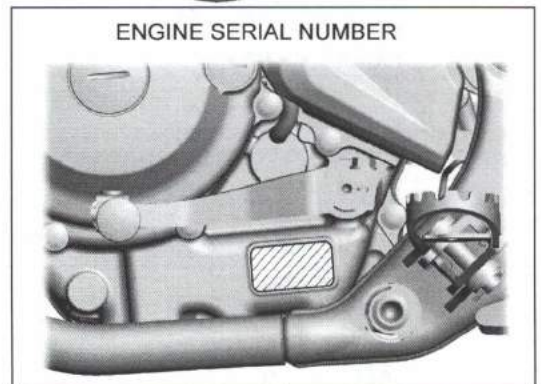
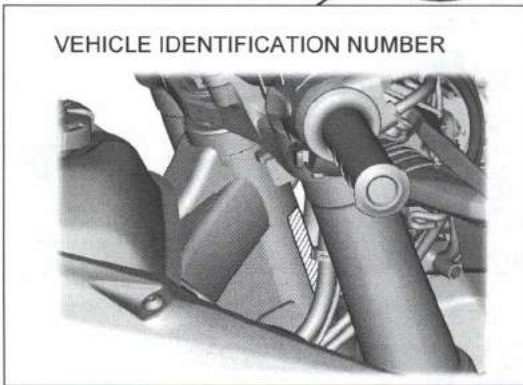



GENERAL INFORMATION

SPECIFICATIONS

GENERAL SPECIFICATIONS

Rally type

ITEM		SPECIFICATIONS	
DIMENSIONS	Overall length	2,230 mm (87.8 in)	
	Overall width	920 mm (36.2 in)	
	Overall height	1,415 mm (55.7 in)	
	Wheelbase	1,455 mm (57.3 in)	
	Seat height	885 mm (34.8 in)	
	Footpeg height	369 mm (14.5 in)	
	Ground clearance	275 mm (10.8 in)	
	Curb weight	LR	150 kg (331 lbs)
		LRA	152 kg (335 lbs)
Maximum weight capacity	AC type	148 kg (326 lbs)	
	CM type	145 kg (320 lbs)	
FRAME	Frame type	Semi-double cradle type	
	Front suspension	Telescopic fork	
	Front axle travel	234 mm (9.2 in)	
	Rear suspension	Pro-link	
	Rear axle travel	260 mm (10.2 in)	
	Front tire size	80/100-21M/C 51P	
	Rear tire size	120/80-18M/C 62P	
	Front tire brand	GP-21F (IRC)	
	Rear tire brand	GP-22R (IRC)	
	Front brake	Hydraulic disc brake	
	Rear brake	Hydraulic disc brake	
	Caster angle	27°30'	
	Trail length	109 mm (4.3 in)	
	Fuel tank capacity	12.8 liter (3.38 US gal, 2.82 Imp gal)	
	Fuel tank reserve capacity	2.3 liter (0.61 US gal, 0.51 Imp gal)	
ENGINE	Cylinder arrangement	Single cylinder 25° inclined from vertical	
	Bore and stroke	76.0 x 63.0 mm (3.00 x 2.50 in)	
	Displacement	286 cm ³ (17.5 cu-in)	
	Compression ratio	10.7:1	
	Valve train	Chain driven, DOHC	
	Intake valve	opens	12° BTDC at 1.0 mm (0.04 in) lift
		closes	31° ABDC at 1.0 mm (0.04 in) lift
	Exhaust valve	opens	40° BBDC at 1.0 mm (0.04 in) lift
		closes	0° ATDC at 1.0 mm (0.04 in) lift
	Lubrication system	Forced pressure and wet sump	
	Oil pump type	Trochoid	
	Cooling system	Liquid cooled	
	Air filtration	Viscous paper filter	
	Engine dry weight	35.9 kg (79.1 lbs)	
	Emission control system	AC type	Crankcase emission control system Secondary air supply system Three-way catalytic converter Evaporative emission control system
		CM type	Crankcase emission control system Secondary air supply system Three-way catalytic converter
	FUEL SYSTEM	Type	PGM-FI
Throttle bore		38 mm (1.5 in)	



ITEM		SPECIFICATIONS	
DRIVE TRAIN	Clutch system	Multi-plate, wet	
	Clutch operation system	Cable operating	
	Transmission	6 speed	
	Primary reduction	2.807 (73/26)	
	Final reduction	2.857 (40/14)	
	Gear ratio	1st	3.538 (46/13)
		2nd	2.250 (36/16)
		3rd	1.650 (33/20)
		4th	1.346 (35/26)
5th		1.115 (29/26)	
6th		0.925 (25/27)	
Gearshift pattern	Left foot operated return system 1 - N - 2 - 3 - 4 - 5 - 6		
ELECTRICAL	Ignition system	Full transistorized	
	Starting system	Electric starter motor	
	Charging system	Triple phase output alternator	
	Regulator/rectifier	FET shorted, triple phase full-wave rectification	
	Lighting system	Battery	



GENERAL INFORMATION

Standard type

ITEM		SPECIFICATIONS	
DIMENSIONS	Overall length	2,230 mm (87.8 in)	
	Overall width	820 mm (32.3 in)	
	Overall height	1,200 mm (47.2 in)	
	Wheelbase	1,455 mm (57.3 in)	
	Seat height	880 mm (34.6 in)	
	Footpeg height	365 mm (14.4 in)	
	Ground clearance	285 mm (11.2 in)	
	Curb weight	L	139 kg (306 lbs)
		LA	141 kg (311 lbs)
Maximum weight capacity	AC type	148 kg (326 lbs)	
	CM type	145 kg (320 lbs)	
FRAME	Frame type	Semi-double cradle type	
	Front suspension	Telescopic fork	
	Front axle travel	234 mm (9.2 in)	
	Rear suspension	Pro-link	
	Rear axle travel	260 mm (10.2 in)	
	Front tire size	80/100-21M/C 51P	
	Rear tire size	120/80-18M/C 62P	
	Front tire brand	GP-21F (IRC)	
	Rear tire brand	GP-22R (IRC)	
	Front brake	Hydraulic disc brake	
	Rear brake	Hydraulic disc brake	
	Caster angle	27°30'	
	Trail length	109 mm (4.3 in)	
	Fuel tank capacity	7.8 liter (2.06 US gal, 1.72 Imp gal)	
	Fuel tank reserve capacity	2.0 liter (0.53 US gal, 0.44 Imp gal)	
ENGINE	Cylinder arrangement	Single cylinder 25° inclined from vertical	
	Bore and stroke	76.0 x 63.0 mm (3.00 x 2.50 in)	
	Displacement	286 cm ³ (17.5 cu-in)	
	Compression ratio	10.7:1	
	Valve train	Chain driven, DOHC	
	Intake valve	opens	12° BTDC at 1.0 mm (0.04 in) lift
		closes	31° ABDC at 1.0 mm (0.04 in) lift
	Exhaust valve	opens	40° BBDC at 1.0 mm (0.04 in) lift
		closes	0° ATDC at 1.0 mm (0.04 in) lift
	Lubrication system	Forced pressure and wet sump	
	Oil pump type	Trochoid	
	Cooling system	Liquid cooled	
	Air filtration	Viscous paper filter	
	Engine dry weight	35.9 kg (79.1 lbs)	
	Emission control system	AC type	Crankcase emission control system Secondary air supply system Three-way catalytic converter Evaporative emission control system
CM type		Crankcase emission control system Secondary air supply system Three-way catalytic converter	
FUEL SYSTEM	Type	PGM-FI	
	Throttle bore	38 mm (1.5 in)	



ITEM		SPECIFICATIONS	
DRIVE TRAIN	Clutch system	Multi-plate, wet	
	Clutch operation system	Cable operating	
	Transmission	6 speed	
	Primary reduction	2.807 (73/26)	
	Final reduction	2.857 (40/14)	
	Gear ratio	1st	3.538 (46/13)
		2nd	2.250 (36/16)
		3rd	1.650 (33/20)
4th		1.346 (35/26)	
5th		1.115 (29/26)	
6th		0.925 (25/27)	
Gearshift pattern		Left foot operated return system 1 - N - 2 - 3 - 4 - 5 - 6	
ELECTRICAL	Ignition system	Full transistorized	
	Starting system	Electric starter motor	
	Charging system	Triple phase output alternator	
	Regulator/rectifier	FET shorted, triple phase full-wave rectification	
	Lighting system	Battery	

FUEL & ENGINE SPECIFICATIONS

FUEL SYSTEM

ITEM	SPECIFICATIONS
Throttle body identification number	GQ9UA
Idle speed	1,450 ± 100 rpm
Throttle grip freeplay	2 – 6 mm (0.1 – 0.2 in)
Fuel pressure at idle	288 – 300 kPa (2.9 – 3.1 kgf/cm ² , 42 – 44 psi)
Fuel pump flow (at 12 V)	55.6 cm ³ (1.88 US oz, 1.96 Imp oz) minimum/10 seconds

LUBRICATION SYSTEM

Unit: mm (in)

ITEM		STANDARD	LIMIT
Engine oil capacity	After draining	1.4 liter (1.5 US qt, 1.2 Imp qt)	–
	After draining/filter change	1.5 liter (1.6 US qt, 1.3 Imp qt)	–
	After disassembly	1.8 liter (1.9 US qt, 1.6 Imp qt)	–
Recommended engine oil		Pro Honda GN4 4-stroke oil (U.S.A. & Canada) or equivalent motorcycle oil API service classification: SJ or higher JASO T903 standard: MA Viscosity: SAE 10W-30	–
Oil pump rotor	Tip clearance	0.15 (0.006)	0.20 (0.008)

COOLING SYSTEM

ITEM	SPECIFICATIONS	
Coolant capacity	Replacement	0.77 liter (0.81 US qt, 0.68 Imp qt)
	After disassembly	0.86 liter (0.91 US qt, 0.76 Imp qt)
Radiator cap relief pressure	107.9 – 137.3 kPa (1.1 – 1.4 kgf/cm ² , 16 – 20 psi)	
Thermostat	Begin to open	81 – 84°C (178 – 183°F)
	Fully open	95°C
	Valve lift	4.5 mm (0.2 in) minimum
Recommended antifreeze		Pro Honda HP Coolant or an equivalent high quality ethylene glycol antifreeze containing corrosion protection inhibitors
Standard coolant concentration		1:1 mixture with distilled water



GENERAL INFORMATION

CYLINDER HEAD/VALVE

Unit: mm (in)

ITEM		STANDARD	LIMIT
Cylinder compression at 490 rpm		1,294 kPa (132 kgf/cm ² , 188 psi)	–
Valve clearance	IN	0.16 ± 0.03 (0.006 ± 0.001)	–
	EX	0.27 ± 0.03 (0.011 ± 0.001)	–
Camshaft	Cam lobe height	IN	30.6878 – 30.8478 (1.20818 – 1.21448)
		EX	30.879 – 31.039 (1.2157 – 1.2220)
Rocker arm, rocker arm shaft	Shaft O.D.	IN/EX	9.972 – 9.987 (0.3926 – 0.3932)
	Arm I.D.	IN/EX	10.000 – 10.015 (0.3937 – 0.3943)
Valve, valve guide	Valve stem O.D.	IN	4.475 – 4.490 (0.1732 – 0.1768)
		EX	4.465 – 4.480 (0.1758 – 0.1764)
	Valve guide I.D.	IN/EX	4.500 – 4.512 (0.1772 – 0.1776)
	Valve guide projection above cylinder head	IN/EX	13.8 – 14.0 (0.54 – 0.55)
	Valve seat width	IN/EX	0.90 – 1.10 (0.035 – 0.043)
Valve spring free length	Inner		35.24 (1.387)
	Outer		39.85 (1.569)
Cylinder head warpage		–	0.10 (0.004)

CYLINDER/PISTON

Unit: mm (in)

ITEM		STANDARD	LIMIT
Cylinder	I.D.	76.000 – 76.010 (2.9921 – 2.9926)	76.1 (3.00)
	Warpage	–	0.10 (0.004)
Piston, Piston pin	Piston O.D. at 11 mm (0.4 in) from bottom of skirt		75.960 – 75.980 (2.9905 – 2.9913)
	Piston pin bore I.D.		17.002 – 17.008 (0.6694 – 0.6694)
	Piston pin O.D.		16.994 – 17.000 (0.6691 – 0.6693)
Piston rings	Piston ring end gap	Top	0.28 – 0.38 (0.011 – 0.015)
		Second	0.40 – 0.55 (0.016 – 0.022)
		Oil (side rail)	0.20 – 0.70 (0.008 – 0.028)
	Piston ring-to-ring groove clearance	Top	0.040 – 0.080 (0.0016 – 0.0031)
		Second	0.015 – 0.050 (0.0006 – 0.0020)
Connecting rod small end I.D.		17.016 – 17.034 (0.6699 – 0.6706)	17.044 (0.6710)

CLUTCH/GEARSHIFT LINKAGE

Unit: mm (in)

ITEM		STANDARD	LIMIT
Clutch lever freeplay		10 – 20 (0.4 – 0.8)	–
Clutch	Disc thickness	2.92 – 3.08 (0.115 – 0.121)	2.70 (0.106)
	Plate warpage	–	0.15
	Clutch spring free length	35.79 (1.409)	34.79 (1.370)
Clutch outer guide I.D.		19.978 – 19.992 (0.7865 – 0.7871)	–
Mainshaft O.D. at clutch outer guide		19.966 – 19.980 (0.7861 – 0.7866)	–

ALTERNATOR/STARTER CLUTCH

Unit: mm (in)

ITEM	STANDARD	LIMIT
Starter driven gear O.D.	51.705 – 51.718 (2.0356 – 2.0361)	–



CRANKCASE/CRANKSHAFT/BALANCER

Unit: mm (in)

ITEM		STANDARD	LIMIT
Connecting rod	Side clearance	0.05 – 0.50 (0.002 – 0.020)	0.60 (0.024)
	Radial clearance	0 – 0.012 (0 – 0.0005)	0.05 (0.002)
Crankshaft	Runout	Right	–
		Left	0.03 (0.001)
	Main journal oil clearance	0.018 – 0.045 (0.0007 – 0.0018)	0.05 (0.002)

TRANSMISSION

Unit: mm (in)

ITEM		STANDARD	LIMIT
Transmission	Gear I.D.	M5, M6	23.000 – 23.021 (0.9055 – 0.9063)
		C1	23.020 – 23.041 (0.9063 – 0.9071)
		C2	25.000 – 25.021 (0.9843 – 0.9851)
		C3, C4	28.000 – 28.021 (1.1024 – 1.1032)
	Gear bushing O.D.	M5, M6	22.959 – 22.980 (0.9039 – 0.9047)
		C1	22.984 – 23.005 (0.9049 – 0.9057)
		C2	24.959 – 24.980 (0.9826 – 0.9835)
		C3, C4	27.959 – 27.980 (1.1007 – 1.1016)
	Gear bushing I.D.	M5, C1	20.000 – 20.021 (0.7874 – 0.7882)
		C2	22.000 – 22.021 (0.8661 – 0.8670)
		C3	25.000 – 25.021 (0.9843 – 0.9851)
	Mainshaft O.D.	at M5 bushing	19.959 – 19.980 (0.7858 – 0.7866)
	Countershaft O.D.	at C1 bushing	19.959 – 19.980 (0.7858 – 0.7866)
		at C2 bushing	21.959 – 21.980 (0.8645 – 0.8854)
		at C3 bushing	24.959 – 24.980 (0.9826 – 0.9835)
Shift fork, shift fork shaft	Fork I.D.	12.000 – 12.018 (0.4724 – 0.4731)	
	Fork shaft O.D.	11.957 – 11.968 (0.4707 – 0.4712)	
	Fork claw thickness	4.93 – 5.00 (0.194 – 0.197)	
Shift drum	Shift drum O.D.	Left side	13.966 – 13.984 (0.5498 – 0.5506)
	Shift drum journal I.D.	Left side	14.000 – 14.027 (0.5512 – 0.5522)

FRAME & CHASSIS SPECIFICATIONS

FRONT WHEEL/SUSPENSION/STEERING

Unit: mm (in)

ITEM		STANDARD	LIMIT
Cold tire pressure	Up to 90 kg (200 lbs) load	150 kPa (1.5 kgf/cm ² , 22 psi)	–
	Up to maximum weight capacity	150 kPa (1.5 kgf/cm ² , 22 psi)	–
Axle runout		–	0.2 (0.01)
Wheel rim runout	Radial	–	2.0 (0.08)
	Axial	–	2.0 (0.08)
Fork (Right)	Spring free length	Rally type	544.9 (21.45)
		Standard type	536.1 (21.11)
	Recommended fluid	Fork Fluid (viscosity: 10W)	
	Fluid level	Rally type	182 (7.2)
		Standard type	171 (6.7)
	Fluid capacity	Rally type	626 ± 2.5 cm ³ (21.2 ± 0.08 US oz, 22.0 ± 0.08 Imp)
Standard type		638 ± 2.5 cm ³ (21.6 ± 0.08 US oz, 22.5 ± 0.08 Imp)	
Fork (Left)	Recommended fluid	Fork Fluid (viscosity: 10W)	
	Fluid level	54 (2.1)	
	Fluid capacity	696 ± 2.5 cm ³ (23.5 ± 0.08 US oz, 24.5 ± 0.08 Imp)	



GENERAL INFORMATION

REAR WHEEL/SUSPENSION

Unit: mm (in)

ITEM		STANDARD	LIMIT
Cold tire pressure	Up to 90 kg (200 lbs) load	150 kPa (1.5 kgf/cm ² , 22 psi)	–
	Up to maximum weight capacity	175 kPa (1.5 kgf/cm ² , 22 psi)	–
Axle runout		–	0.2 (0.01)
Wheel rim runout	Radial	–	2.0 (0.08)
	Axial	–	2.0 (0.08)
Drive chain slack		50 – 55 (2.0 – 2.2)	57 (2.2)
Drive chain size/link		DID 520VF-106LE	–

HYDRAULIC BRAKE

Unit: mm (in)

ITEM		STANDARD	LIMIT
Front	Specified brake fluid	DOT 3 or 4 brake fluid	–
	Brake disc thickness	3.5 ± 0.2 (0.14 ± 0.01)	3.0 (0.12)
	Brake disc warpage	–	0.30 (0.012)
	Master cylinder I.D.	12.700 – 12.743 (0.5000 – 0.5017)	–
	Master piston O.D.	12.657 – 12.684 (0.4983 – 0.4994)	–
	Caliper cylinder I.D.	27.000 – 27.050 (1.0630 – 1.0650)	–
	Caliper piston O.D.	26.918 – 26.968 (1.0598 – 1.0617)	–
Rear	Specified brake fluid	DOT 3 or 4 brake fluid	–
	Brake disc thickness	4.5 ± 0.2 (0.18 ± 0.01)	4.0 (0.16)
	Brake disc warpage	–	0.30 (0.012)
	Master cylinder I.D.	12.700 – 12.743 (0.5000 – 0.5017)	–
	Master piston O.D.	12.657 – 12.684 (0.4983 – 0.4994)	–
	Caliper cylinder I.D.	27.000 – 27.050 (1.0630 – 1.0650)	–
	Caliper piston O.D.	26.918 – 26.968 (1.0598 – 1.0617)	–

ELECTRICAL SYSTEM SPECIFICATIONS

PGM-FI SYSTEM

ITEM	SPECIFICATIONS
Fuel injector resistance	11 – 13 Ω
PAIR control solenoid valve resistance (20°C/68°F)	24 – 28 Ω
EVAP purge control solenoid valve resistance (20°C/68°F)	AC type only 30 – 34 Ω

ABS SYSTEM

Unit: mm (in)

ITEM	SPECIFICATIONS	
Air gap	Front	0.8 – 1.4 (0.03 – 0.06)
	Rear	0.7 – 1.3 (0.03 – 0.05)

IGNITION SYSTEM

ITEM	SPECIFICATIONS
Spark plug	SIMR8A9 (NGK)
Spark plug gap	0.8 – 0.9 mm (0.03 – 0.04 in)
Ignition coil peak voltage	100 V minimum
CKP sensor peak voltage	0.7 V minimum
Ignition timing ("F"mark)	10° BTDC at idle speed



BATTERY/CHARGING SYSTEM

ITEM		SPECIFICATIONS	
Battery	Type	YTZ8V	
	Capacity	12 V – 7 Ah (10 HR)	
	Voltage	Fully charged	12.8 V minimum
		Needs charging	Below 12.4 V
	Charging current	Normal	0.7 A/5 – 10 h
Quick		3.5 A/1 h	
Current leakage		0.105 mA maximum	
Alternator	Capacity	0.34 kW/5,000 rpm	
	Charging coil resistance (20°C/68°F)	0.1 – 1.0 Ω	

LIGHTS/METERS/SWITCHES

ITEM		SPECIFICATIONS	
Bulbs	Headlight	Standard type 12 V - 55/60 W	
	Brake/taillight	12 V - 21/5 W	
	Front position/turn signal light	12 V - 5/21 W	
	Rear turn signal light	12 V - 21 W	
Fuse	Main fuse	30 A	
	Sub fuse	Standard type	10 A x 5
		Rally type	10 A x 6
ABS fuse	ABS type only	10 A, 30A x 2	



GENERAL INFORMATION

TORQUE VALUE

- Each fastener should be tightened to the standard torque value except the fasteners specified torque value.
- Q'TY: Quantity, DIA: Thread diameter [mm], TRQ: Tightening torque [N·m (kgf·m, lbf·ft)]

STANDARD TIGHTENING TORQUE

FASTENER TYPE	TRQ	FASTENER TYPE	TRQ
5 mm hex bolt and nut	5.2 (0.5, 3.8)	5 mm screw	4.2 (0.4, 3.1)
6 mm hex bolt and nut	10 (1.0, 7)	6 mm screw	9.0 (0.9, 6.6)
8 mm hex bolt and nut	22 (2.2, 16)	6 mm flange bolt	12 (1.2, 9)
10 mm hex bolt and nut	34 (3.5, 25)	8 mm flange bolt and nut	27 (2.8, 20)
12 mm hex bolt and nut	54 (5.5, 40)	10 mm flange bolt and nut	39 (4.0, 29)

FUEL PUMP UNIT

ITEM	Q'TY	DIA	TRQ	REMARKS
Fuel pump setting plate nut	4	6	12 (1.2, 9)	→2-4

FUEL TANK

ITEM	Q'TY	DIA	TRQ	REMARKS
Fuel filler cap bolt (Rally type only)	3	4	1.8 (0.2, 1.3)	

AIR CLEANER

ITEM	Q'TY	DIA	TRQ	REMARKS
Air cleaner cover screw	4	5	1.2 (0.1, 0.9)	
Air cleaner housing mounting bolt	1	6	7.0 (0.7, 5)	
Air cleaner connecting hose band screw	1	4	1.5 (0.2, 1.1)	

THROTTLE BODY

ITEM	Q'TY	DIA	TRQ	REMARKS
Throttle cable A lock nut (throttle body side)	1	6	3.0 (0.3, 2.2)	
Throttle cable B lock nut (throttle body side)	1	6	3.0 (0.3, 2.2)	
Sensor unit torx screw	3	5	3.4 (0.3, 2.5)	
IACV setting plate torx screw	2	4	2.1 (0.2, 1.5)	
Throttle cable holder screw	2	5	3.4 (0.3, 2.5)	
Injector joint mounting bolt	2	5	5.1 (0.5, 3.8)	

SECONDARY AIR SUPPLY SYSTEM

ITEM	Q'TY	DIA	TRQ	REMARKS
PAIR check valve cover bolt	2	5	5.2 (0.5, 3.8)	

LUBRICATION SYSTEM

ITEM	Q'TY	DIA	TRQ	REMARKS
Oil drain bolt	1	12	24 (2.4, 18)	

COOLING SYSTEM

ITEM	Q'TY	DIA	TRQ	REMARKS
Cooling fan nut	1	3	1.0 (0.1, 0.7)	Apply locking agent.
Fan motor screw	3	4	2.7 (0.3, 2.0)	
Water pump impeller	1	7	10 (1.0, 7)	

CYLINDER HEAD

ITEM	Q'TY	DIA	TRQ	REMARKS
Crankshaft hole cap	1	30	8.0 (0.8, 5.9)	Apply engine oil.
Timing hole cap	1	14	6.0 (0.6, 4.4)	Apply engine oil.
Cylinder head cover bolt	2	6	10 (1.0, 7)	
Cam chain tensioner lifter plug	1	6	4.2 (0.4, 3.1)	
Camshaft holder mounting bolt	8	6	12 (1.2, 9)	Apply engine oil.
Cylinder head mounting nut	4	10	45 (4.6, 33)	Apply engine oil.
Cylinder head sealing bolt	2	12	15 (1.5, 11)	

CYLINDER/PISTON

ITEM	Q'TY	DIA	TRQ	REMARKS
Cylinder stud bolt	4	10	–	→2-29

CLUTCH/GEARSHIFT LINKAGE

ITEM	Q'TY	DIA	TRQ	REMARKS
Clutch center lock nut	1	16	108 (11.0, 80)	Lock nut; replace with a new one and stake. Apply engine oil.
Clutch lifter plate bolt	3	6	12 (1.2, 9)	
Primary drive gear lock nut	1	16	108 (11.0, 80)	Apply engine oil.
Shift drum stopper arm bolt	1	6	10 (1.0, 7)	Apply locking agent.*
Shift drum stopper plate bolt	1	6	10 (1.0, 7)	Apply locking agent.*

ALTERNATOR/STARTER CLUTCH

ITEM	Q'TY	DIA	TRQ	REMARKS
Starter clutch socket bolt	6	8	30 (3.1, 22)	Apply locking agent.
Flywheel bolt	1	12	128 (13.1, 94)	Apply engine oil.
CKP sensor mounting socket bolt	2	6	10 (1.0, 7)	Apply locking agent.*
Stator mounting socket bolt	3	6	10 (1.0, 7)	

CRANKCASE/TRANSMISSION/BALANCER

ITEM	Q'TY	DIA	TRQ	REMARKS
Cam chain tensioner pivot bolt	1	6	10 (1.0, 7)	Apply locking agent.*
Balancer shaft nut	1	14	69 (7.0, 51)	Apply engine oil.

ENGINE UNIT

ITEM	Q'TY	DIA	TRQ	REMARKS	
Engine hanger plate bolt	4	8	27 (2.8, 20)		
Engine hanger nut	Front upper	1	10	55 (5.6, 41)	
	Front lower	1	10	55 (5.6, 41)	
	Rear upper	1	10	45 (4.6, 33)	
	Rear lower	1	10	45 (4.6, 33)	
Drive sprocket fixing plate bolt	2	6	10 (1.0, 7)		

BODY PANELS

ITEM	Q'TY	DIA	TRQ	REMARKS
Wind screen screw (Rally type only)	3	5	0.75 (0.1, 0.6)	
Hook bolt	4	8	21 (2.1, 15)	
Brake lever pivot bolt	1	6	1.0 (0.1, 0.7)	
Brake lever pivot nut	1	6	5.9 (0.6, 4.4)	
Battery box bolt	3	6	7.0 (0.7, 5.2)	
Rearview mirror lock nut	2	10	20 (2.0, 15)	Left-hand threads
Rearview mirror adaptor bolt	2	10	20 (2.0, 15)	

SIDESTAND

ITEM	Q'TY	DIA	TRQ	REMARKS
Sidestand pivot bolt	1	10	10 (1.0, 7)	
Sidestand pivot nut	1	10	30 (3.1, 22)	Self lock nut
Sidestand switch bolt	1	6	10 (1.0, 7)	Pre-coated (ALOC) bolt, replace with a new one.



GENERAL INFORMATION

EXHAUST PIPE/MUFFLER

ITEM	Q'TY	DIA	TRQ	REMARKS
Exhaust pipe stud bolt	2	8	–	→3-24
Exhaust pipe joint nut	2	8	18 (1.8, 13)	
Muffler mounting bolt	2	8	32 (3.3, 24)	
Muffler band bolt	1	8	23 (2.3, 17)	
Exhaust pipe protector bolt (Standard type only)	2	6	12 (1.2, 9)	

FRONT WHEEL

ITEM	Q'TY	DIA	TRQ	REMARKS
Front axle bolt	1	14	69 (7.0, 51)	
Front axle holder bolt	2	8	22 (2.2, 16)	
Front brake disc bolt	6	6	20 (2.0, 15)	Pre-coated (ALOC) bolt, re- place with a new one.
Front spoke	36	BC 3.2	3.7 (0.4, 2.7)	

FORK

ITEM	Q'TY	DIA	TRQ	REMARKS
Top bridge pinch bolt	4	8	29 (3.0, 21)	
Bottom bridge pinch bolt	4	8	29 (3.0, 21)	
Fork center bolt	1	8	20 (2.0, 15)	Apply locking agent.
Fork rod nut	2	10	20 (2.0, 15)	
Fork cap	2	50	35 (3.6, 26)	
Fork protector bolt	6	6	7.0 (0.7, 5.2)	Pre-coated (ALOC) bolt, re- place with a new one.

HANDLEBAR

ITEM	Q'TY	DIA	TRQ	REMARKS
Left handlebar switch screw	2	5	2.5 (0.3, 1.8)	
Right handlebar switch screw	2	5	2.5 (0.3, 1.8)	

STEERING STEM

ITEM	Q'TY	DIA	TRQ	REMARKS
Steering stem nut	1	24	103 (10.5, 76)	
Steering stem adjusting nut	1	26	–	→3-33
Front brake hose guide bolt	2	6	10 (1.0, 7)	
Front brake hose clamp bolt	2	6	10 (1.0, 7)	

REAR WHEEL

ITEM	Q'TY	DIA	TRQ	REMARKS
Rear axle nut	1	16	88 (9.0, 65)	Self lock nut
Driven sprocket nut	6	8	32 (3.3, 24)	Self lock nut
Drive chain adjuster lock nut	2	8	27 (2.8, 20)	UBS nut
Rear brake disc bolt	4	8	42 (4.3, 31)	Pre-coated (ALOC) bolt, re- place with a new one.
Rear spoke	32	BC 3.2	3.7 (0.4, 2.7)	

REAR SUSPENSION

ITEM	Q'TY	DIA	TRQ	REMARKS
Shock absorber upper nut	1	10	44 (4.5, 32)	Self lock nut
Shock absorber lower nut	1	10	44 (4.5, 32)	Self lock nut
Shock link bolt (Frame side)	1	10	44 (4.5, 32)	Self lock nut
Shock link nut (Shock arm side)	1	10	44 (4.5, 32)	Self lock nut
Shock arm-to-swingarm nut	1	12	74 (7.5, 55)	Self lock nut Apply engine oil.
Swingarm pivot nut	1	14	88 (9.0, 65)	Self lock nut
Drive chain slider bolt	4	5	4.2 (0.4, 3.1)	Pre-coated (ALOC) bolt, re- place with a new one.
Drive chain slider side bolt	1	5	4.2 (0.4, 3.1)	Pre-coated (ALOC) bolt, re- place with a new one.
Drive chain guide bolt	2	6	10 (1.0, 7)	Pre-coated (ALOC) bolt, re- place with a new one.
Drive chain slider guide nut	2	6	2.5 (0.3, 1.8)	Self lock nut
Rear brake hose guide mounting screw	2	5	1.2 (0.1, 0.9)	

FRONT BRAKE

ITEM	Q'TY	DIA	TRQ	REMARKS
Front brake hose oil bolt	2	10	34 (3.5, 25)	
Front master cylinder holder bolt	2	6	9.8 (1.0, 7.2)	
Front master cylinder reservoir cover screw	2	4	1.5 (0.2, 1.1)	
Front brake light switch screw	1	4	1.2 (0.1, 0.9)	
Front brake caliper mounting bolt	2	8	30 (3.1, 22)	Pre-coated (ALOC) bolt, re- place with a new one.
Front brake caliper bleed valve	1	8	5.4 (0.6, 4.0)	
Front brake caliper torque nut	1	8	22 (2.2, 16)	Apply locking agent.
Front brake caliper pin bolt	1	8	17 (1.7, 13)	
Front brake pad hanger pin	1	10	17 (1.7, 13)	

REAR BRAKE

ITEM	Q'TY	DIA	TRQ	REMARKS
Rear brake hose oil bolt	2	10	34 (3.5, 25)	
Rear master cylinder bolt	2	6	14 (1.4, 10)	Pre-coated (ALOC) bolt, re- place with a new one.
Rear master cylinder reservoir cover screw	2	4	1.5 (0.2, 1.1)	
Rear master cylinder push rod nut	1	8	17 (1.7, 13)	
Rear brake caliper nut	1	8	22 (2.2, 16)	Apply locking agent.
Rear brake caliper pin bolt	1	8	12 (1.2, 9)	Apply locking agent.
Rear brake pad hanger pin	1	10	17 (1.7, 13)	
Rear brake caliper bleed valve	1	8	5.4 (0.6, 4.0)	

PGM-FI SYSTEM

ITEM	Q'TY	DIA	TRQ	REMARKS
ECT sensor	1	12	25 (2.5, 18)	
O ₂ sensor	1	12	25 (2.5, 18)	
Bank angle sensor nut	2	6	9.0 (0.9, 6.6)	

IGNITION SYSTEM

ITEM	Q'TY	DIA	TRQ	REMARKS
Spark plug	1	10	16 (1.6, 12)	

ELECTRICAL STARTER

ITEM	Q'TY	DIA	TRQ	REMARKS
Negative brush screw	1	5	3.7 (0.4, 2.7)	
Starter motor assembly bolt	2	5	4.9 (0.5, 3.6)	
Gear position switch	1	6	10 (1.0, 7)	



GENERAL INFORMATION

ABS

ITEM	Q'TY	DIA	TRQ	REMARKS
Brake pipe joint nut	4	10	14 (1.4, 10)	

LIGHTING SYSTEM

ITEM	Q'TY	DIA	TRQ	REMARKS
Headlight unit mounting bolt (Rally type)	4	6	8.5 (0.9, 6.3)	
Headlight unit mounting screw (Rally type)	3	5	1.2 (0.1, 0.9)	
Brake/taillight mounting bolt	2	6	4.5 (0.5, 3.3)	
Turn signal light screw (Rally type)	2	6	2.5 (0.3, 1.8)	
Turn signal light screw (Standard type)	4	6	2.5 (0.3, 1.8)	
Turn signal light lens screw	4	4	1.5 (0.2, 1.1)	

COMBINATION METER

ITEM	Q'TY	DIA	TRQ	REMARKS
Meter screw	4	5	1.0 (0.1, 0.7)	

ELECTRICAL COMPONENT

ITEM	Q'TY	DIA	TRQ	REMARKS
Ignition switch bolt	2	8	24 (2.4, 18)	One-way bolt, replace with a new one.

OTHERS

ITEM	Q'TY	DIA	TRQ	REMARKS
Throttle cable A lock nut (grip side)	1	10	1.5 (0.2, 1.1)	
Throttle cable A lock nut (adjust nut)	1	7	3.8 (0.4, 2.8)	
Throttle cable B lock nut (grip side)	1	12	1.5 (0.2, 1.1)	
Brake/taillight cover mounting screw	2	5	4.5 (0.5, 3.3)	
Headlight unit plate screw (Standard type)	2	5	1.5 (0.2, 1.1)	
Rear reflector nut	1	5	1.7 (0.2, 1.3)	Self lock nut
Side reflector nut	2	6	1.7 (0.2, 1.3)	Self lock nut
License light mounting screw	2	4	2.0 (0.2, 1.5)	
Clutch lever pivot bolt	1	6	1.0 (0.1, 0.7)	
Clutch lever pivot nut	1	6	5.9 (0.6, 4.4)	
Gearshift spindle return spring pin	1	8	30 (3.1, 22)	Apply locking agent.

- *: Apply locking agent to the threads as shown.

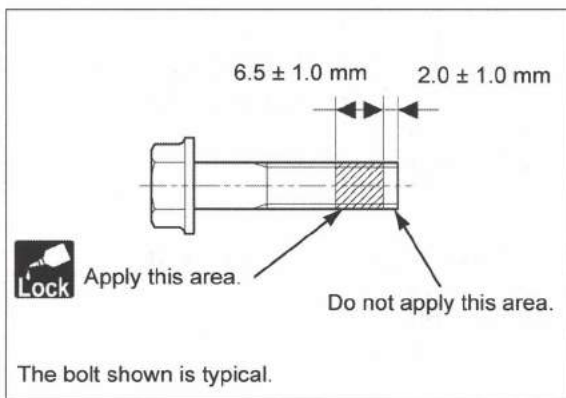



SPECIAL TOOL LIST

TOOL No./TOOL NAME		U.S.A. TOOL No./U.S.A. TOOL NAME
Fuel & Engine		
07406-0040004	Fuel pressure gauge	07406-004000B
070MJ-K260100	Fuel pressure gauge attachment	07AMJ-K26A100 (Use With: 07AMJ-HW1A100, 07AAJ-S6MA200, 07406-004000C)
070MF-KVS0300	Fuel pump case remover	
070MZ-0010300	SCS connector	070MZ-001A300
07HMF-KR10101	Oil seal driver 30 x 36 mm	
07709-0010001	Timing cap wrench	
070MG-0010100	Cam chain tensioner lifter stopper	07AMG-001A100 or 07AMG-MFJA100
07757-0010000	Valve spring compressor	
07959-KM30101	Valve spring compressor attachment	
07HMH-ML00101	Valve guide reamer, 4.5 mm	07HMH-ML0010B
07HMD-ML00101	Valve guide driver, 4.3 mm	
07743-0020000	Valve guide driver	07742-0010100
07724-0050002	Clutch center holder	equivalent commercially available in U.S.A.
07724-0010200	Gear holder, M1.5	strap wrench equivalent commercially available in U.S.A.
07PAF-0010620	Pilot collar, 16 mm	U.S.A. Use commercially available tool
07746-0050200	Bearing remover head, 10 mm	U.S.A. Use commercially available tool
07725-0040001	Flywheel holder	equivalent commercially available in U.S.A.
07733-0020001	Flywheel puller	07933-2160000
07724-0010100	Gear holder, M2.5	U.S.A. use 07724-001A100
070MF-KYJ0100	Metal installer set	U.S.A. use 070MF-KYJA100
Frame & Chassis		
07746-0050500	Remover head, 17 mm	
07746-0050100	Bearing remover shaft	equivalent commercially available in U.S.A.
07746-0010100	Attachment, 32 x 35 mm	
07746-0040400	Pilot 17 mm	
07749-0010000	Driver	
07KMD-KZ30100	Fork seal driver, 45.2 mm	07KMD-KZ3010A
07NMD-KZ30101	Fork seal driver attachment	07NMD-KZ3010A
07916-3710101	Steering stem socket	07702-0020001
07948-4630100	Ball race remover	07953-MJ1000B
07GMD-KS40100	Ball race remover 36 x L340	
07946-4300101	Driver, 28 mm I.D.	07946-MB0000D and 07946-KA6000A
07746-0010300	Attachment, 42 x 47 mm	
07914-SA50001	Snap ring pliers	07914-SA50001
Electrical System		
07HGJ-0020100	Peak voltage adapter	commercially available digital multimeter (impedance 10M)



CABLE & HARNESS ROUTING

Rally type:

ABS:

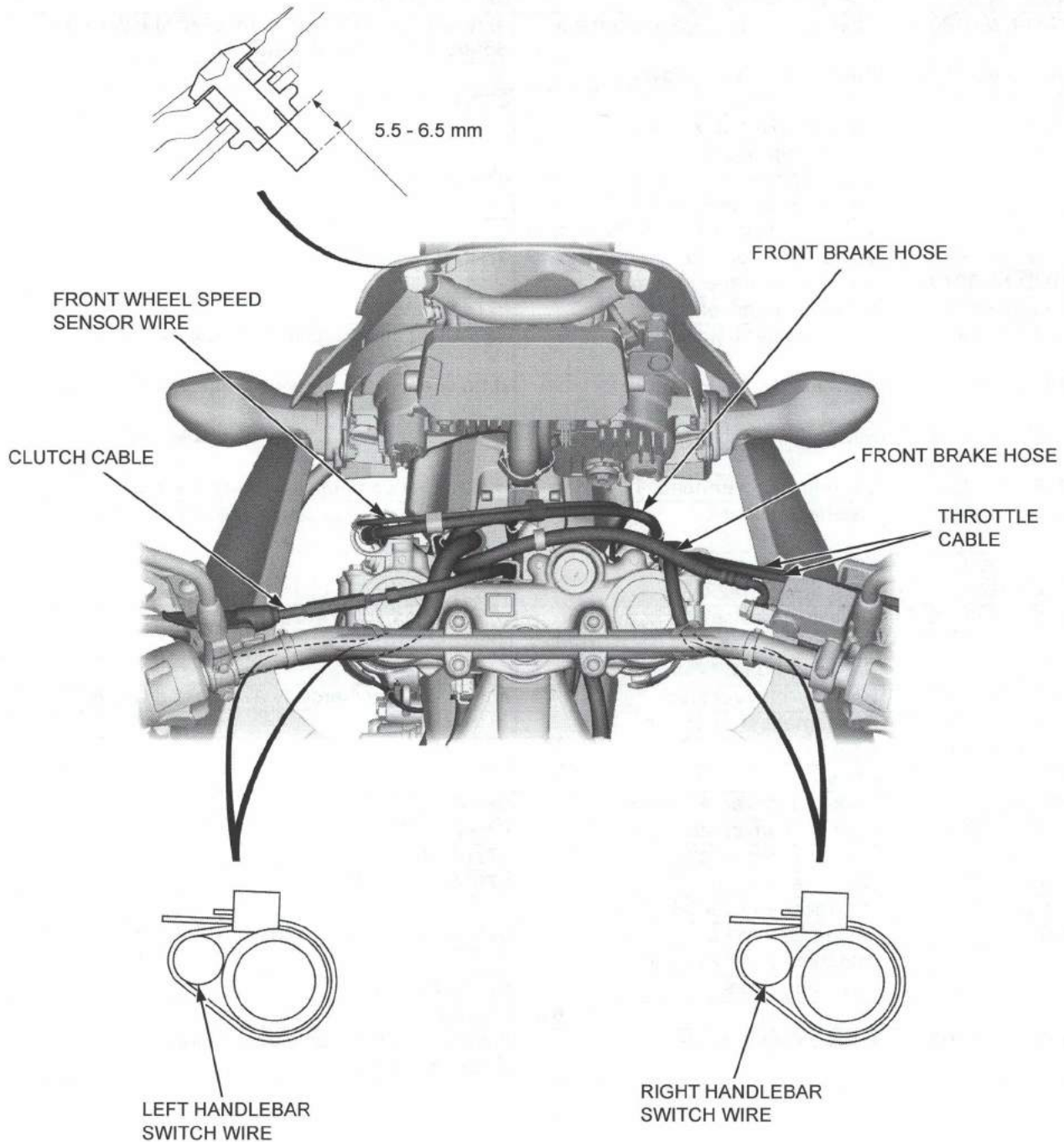



Except ABS:

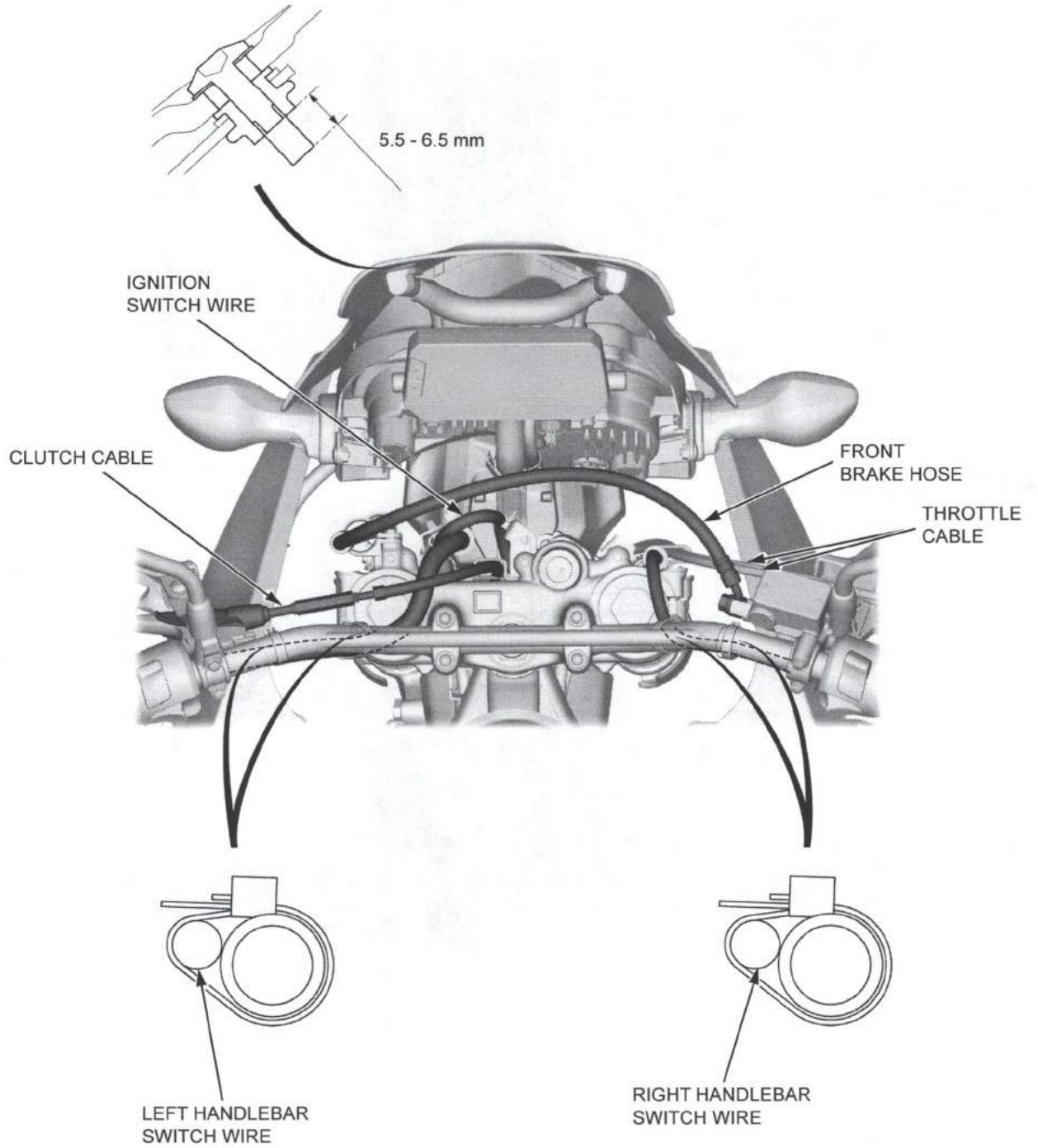



GENERAL INFORMATION

ABS:

COMBINATION METER
28P CONNECTOR

REAR ABS CANCEL
SWITCH WIRE

REAR ABS CANCEL SWITCH
2P CONNECTOR

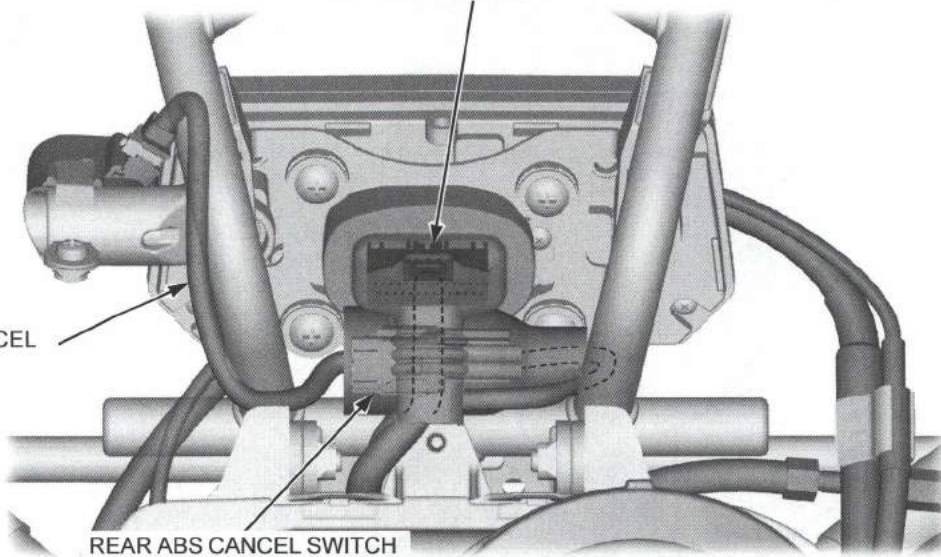

Except ABS:

COMBINATION METER
28P CONNECTOR

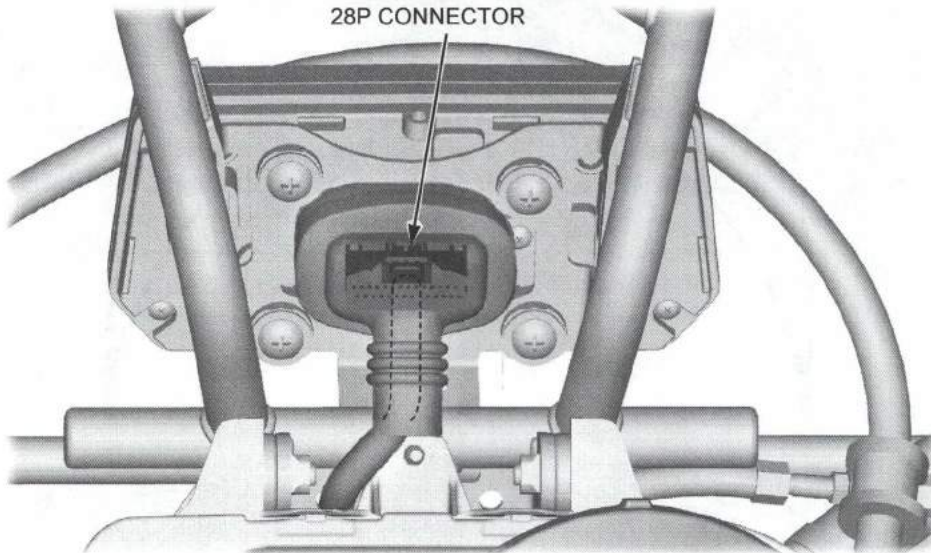

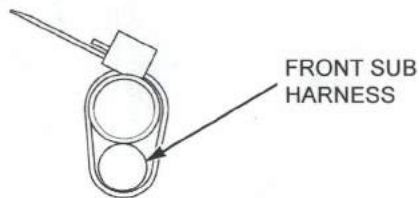
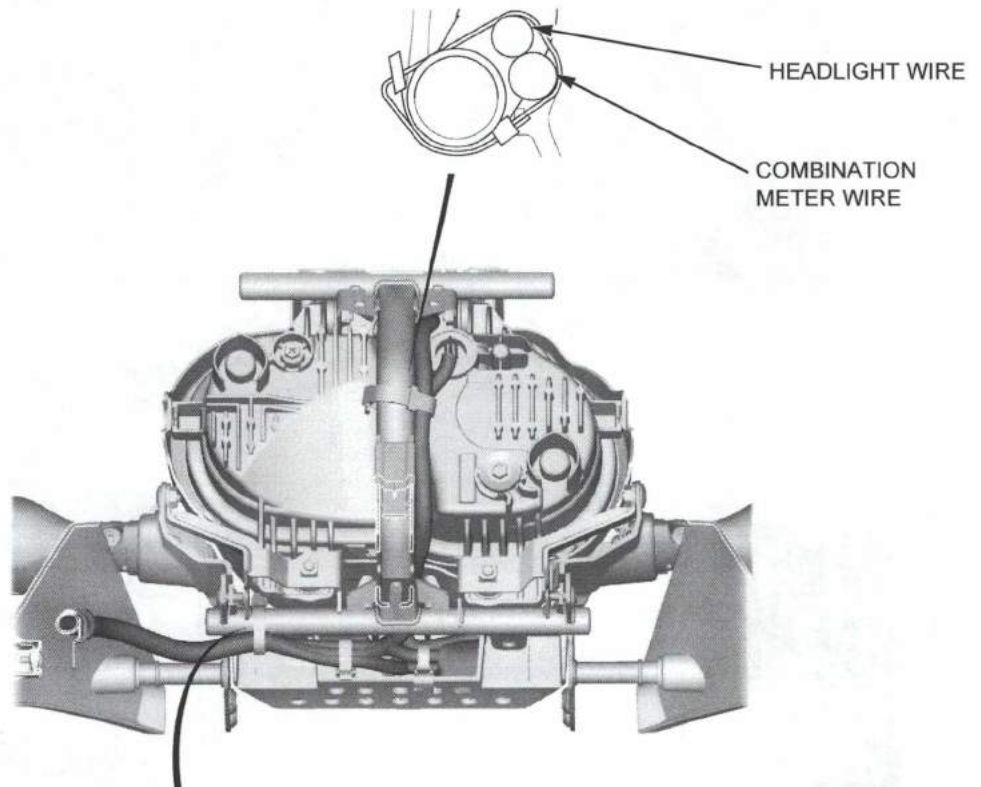
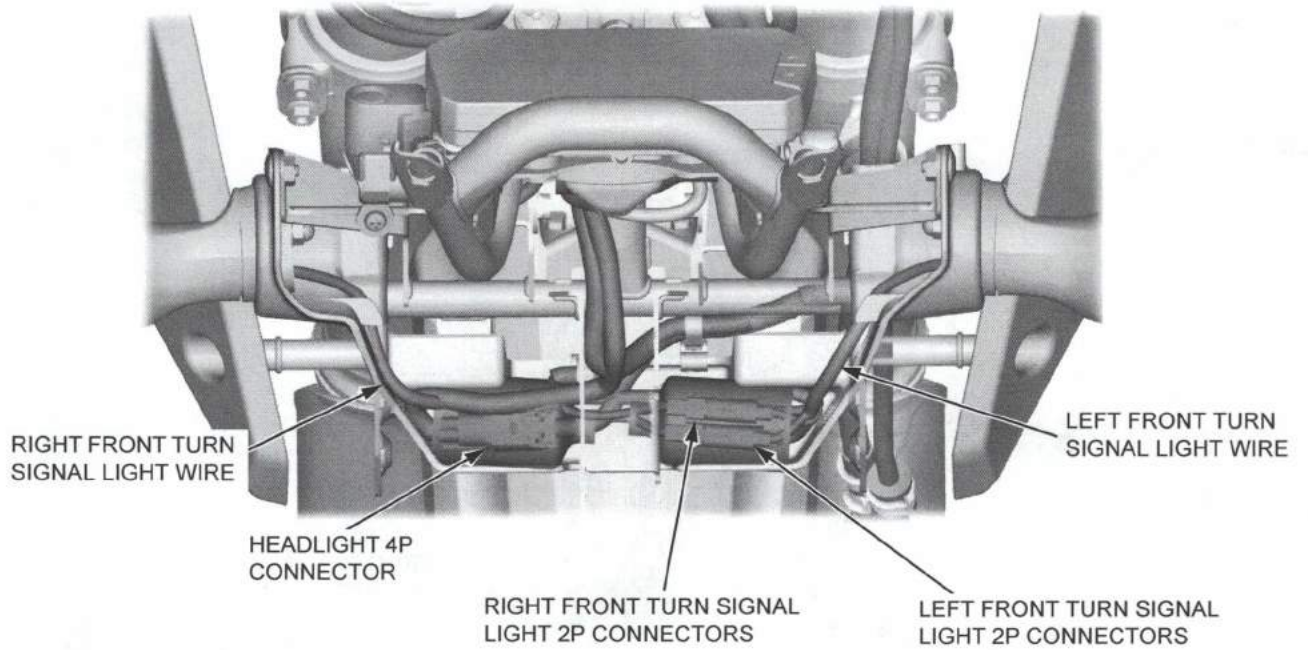



GENERAL INFORMATION

ABS:

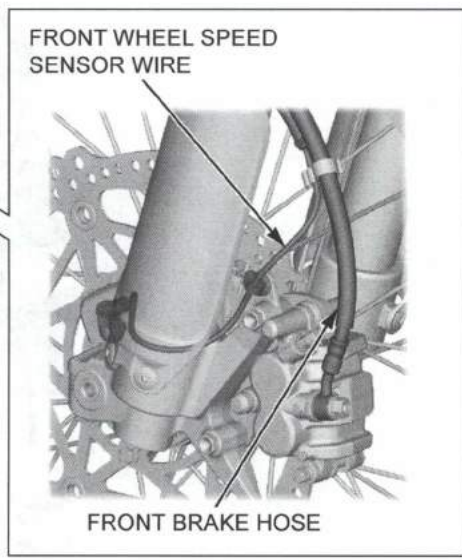
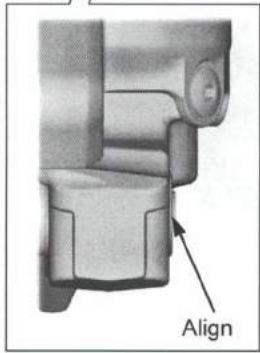
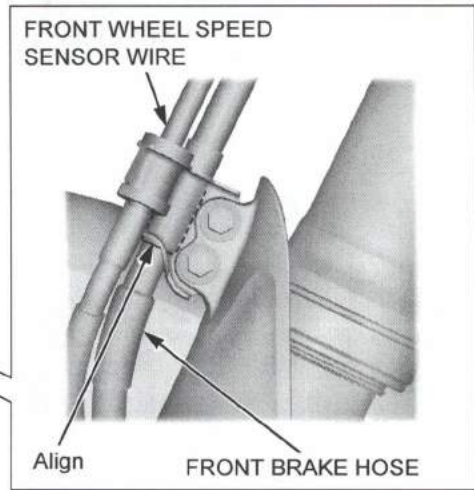
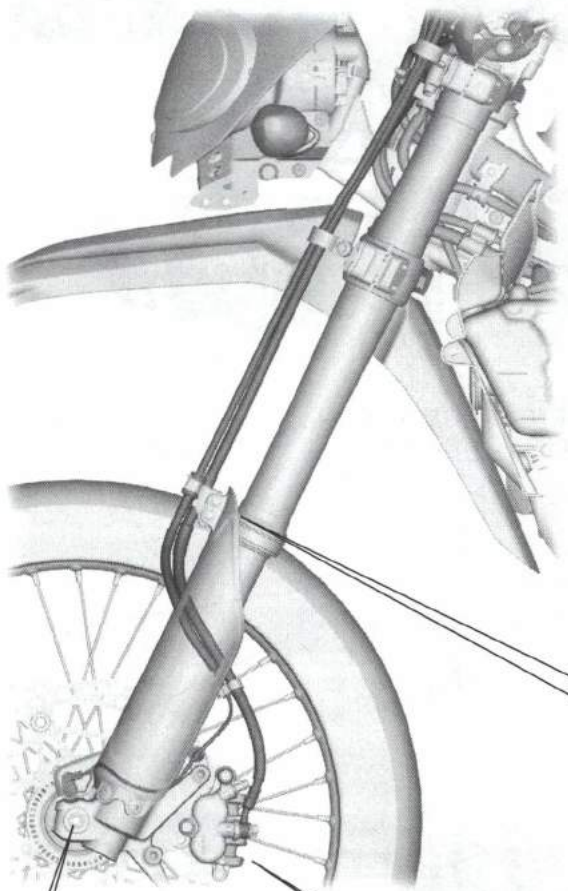



Except ABS:

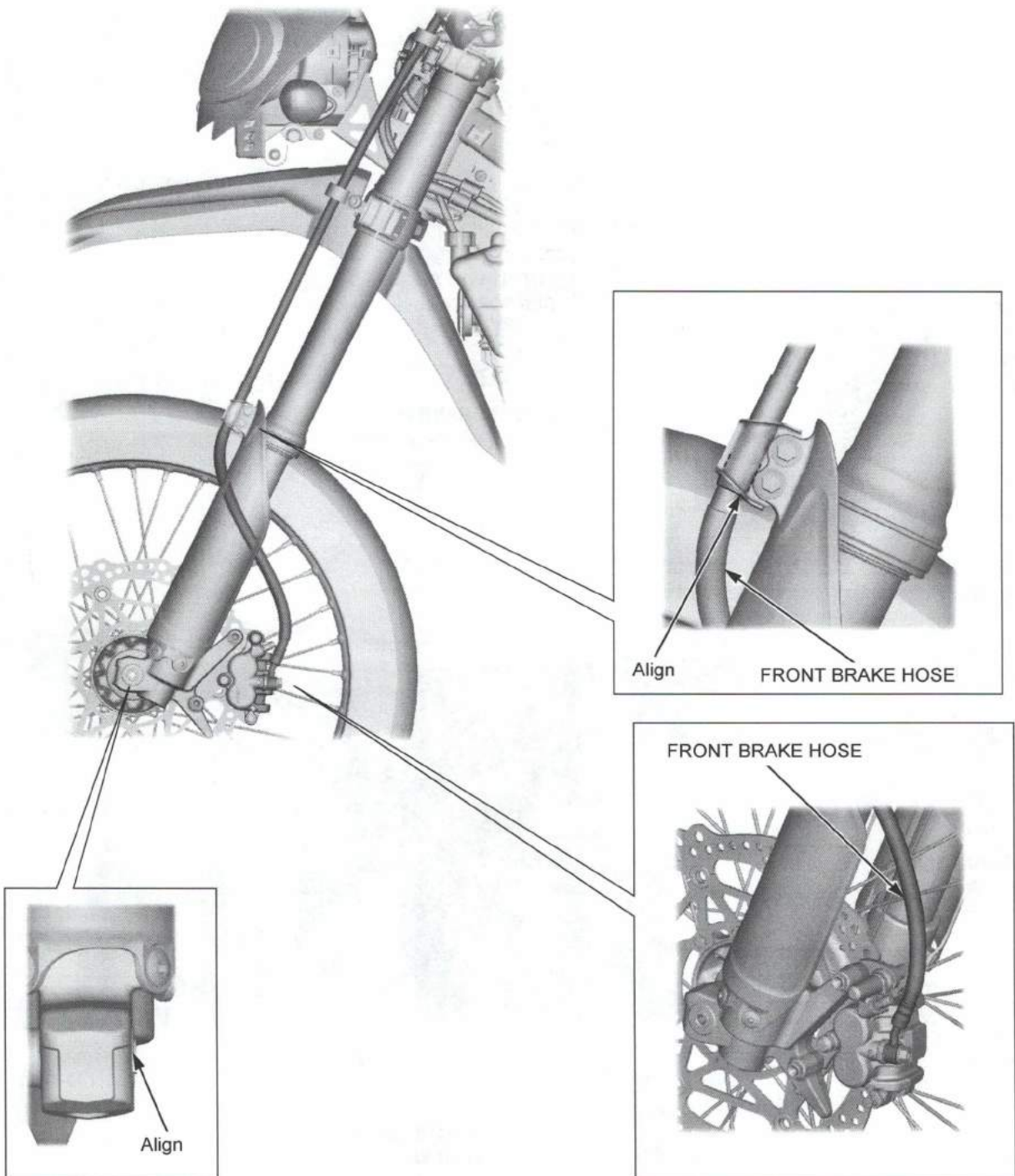



GENERAL INFORMATION

ABS:

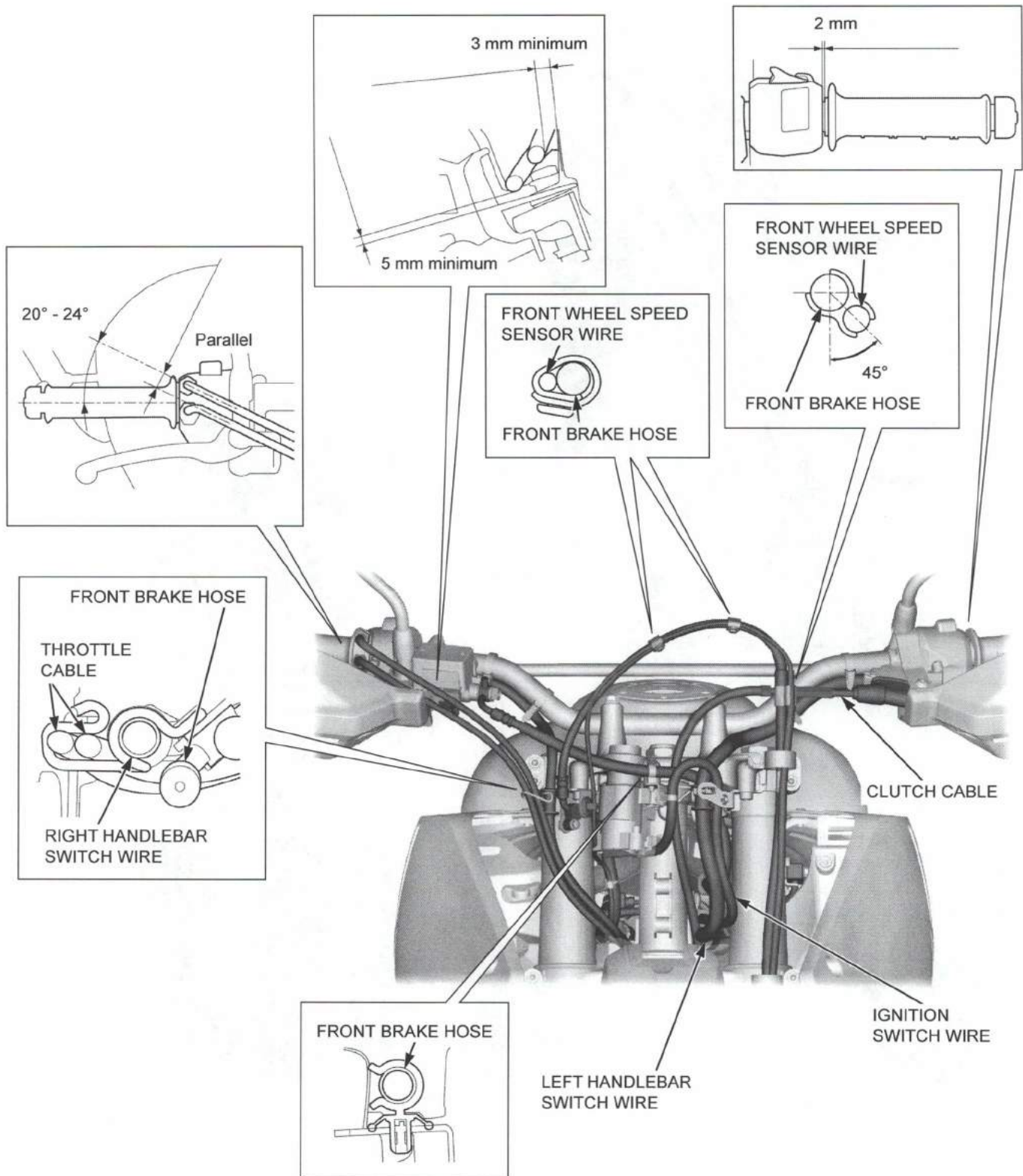



Except ABS:

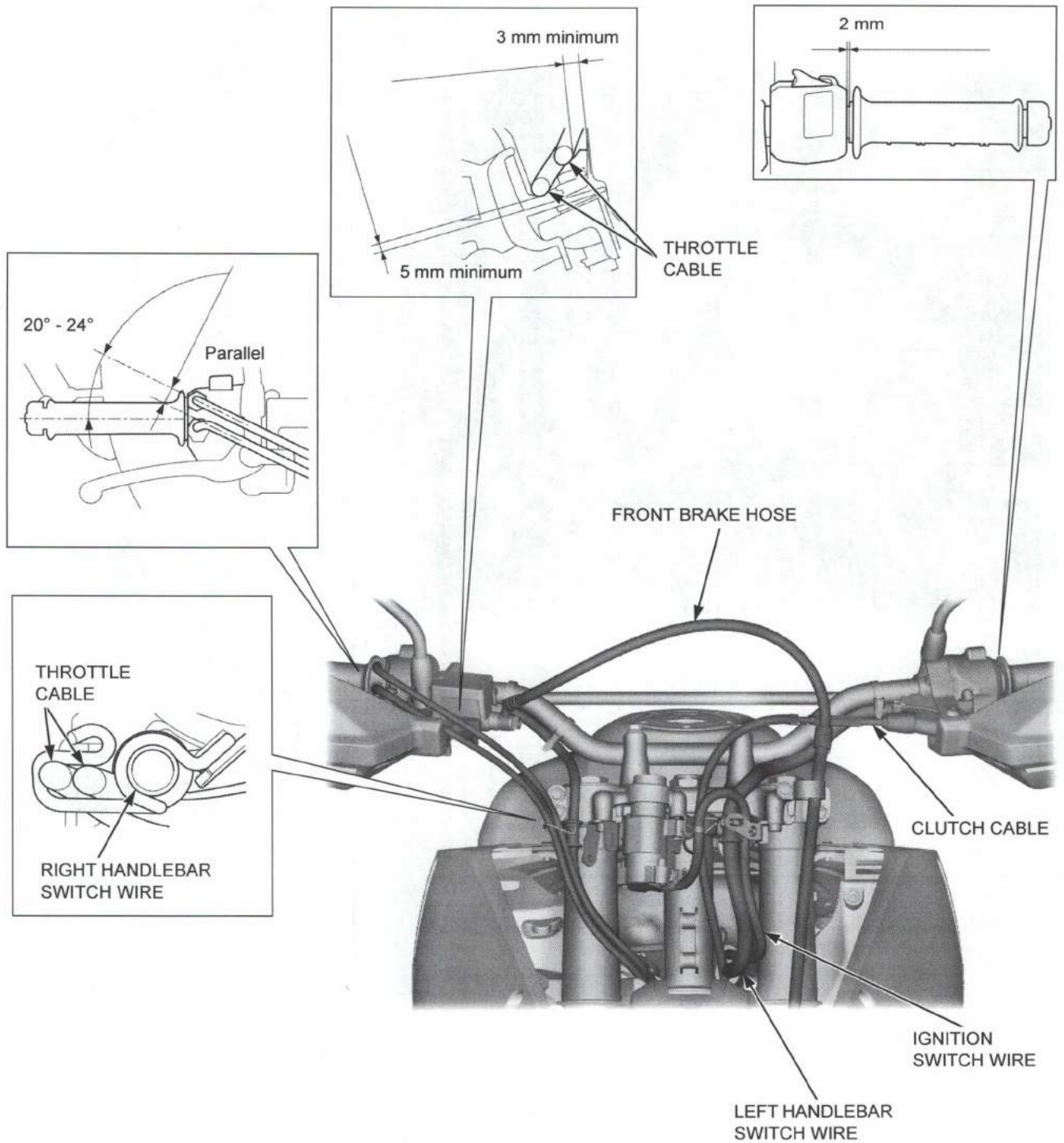

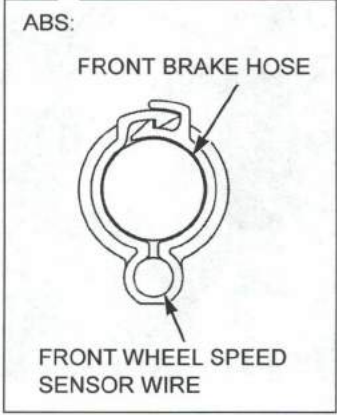
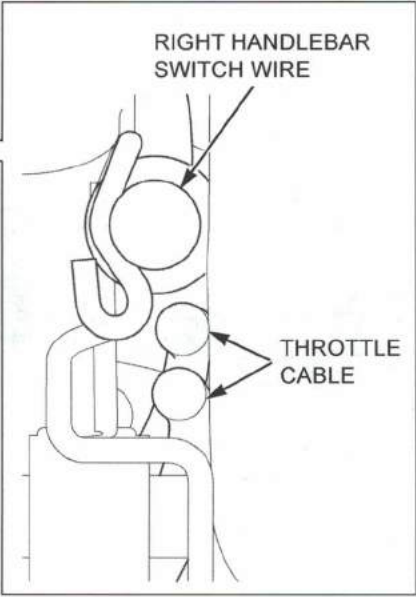
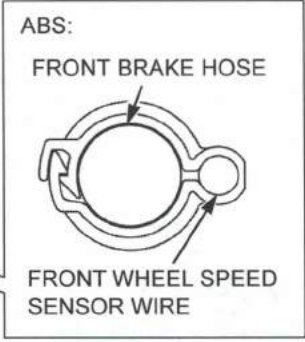
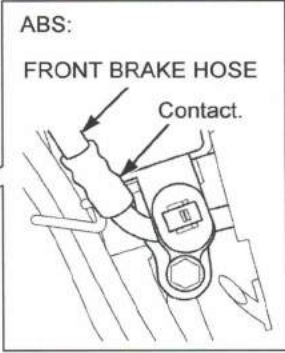
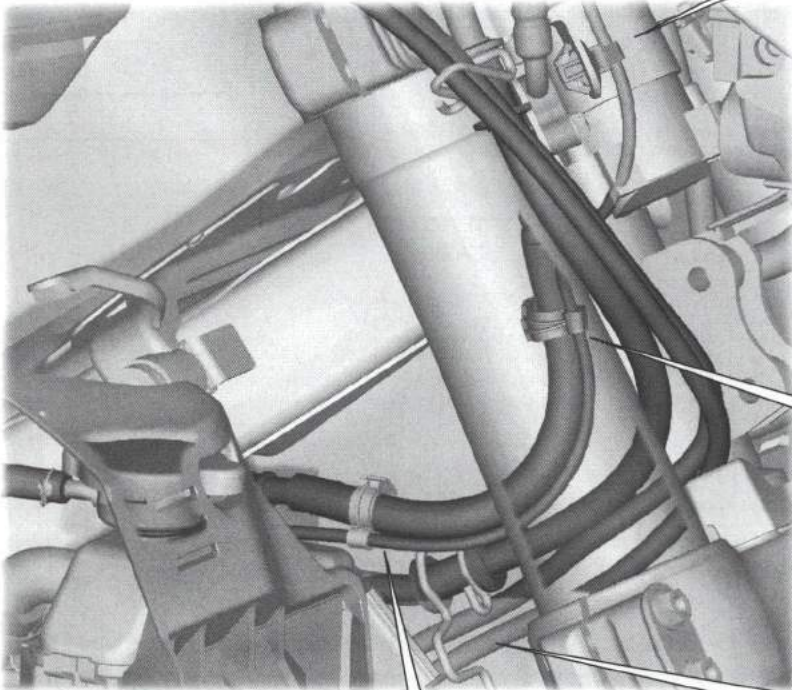

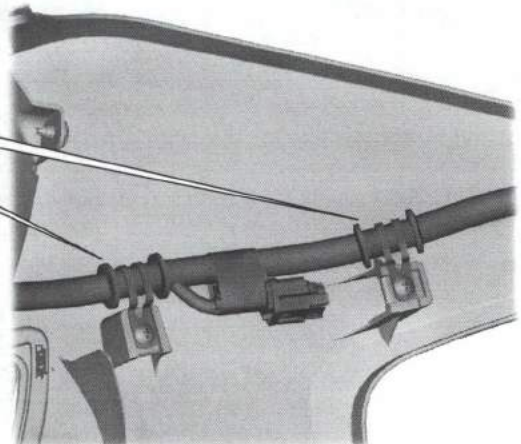
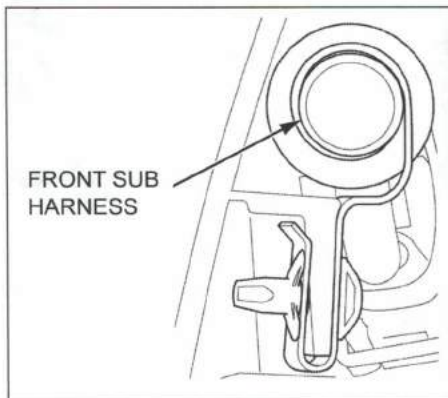
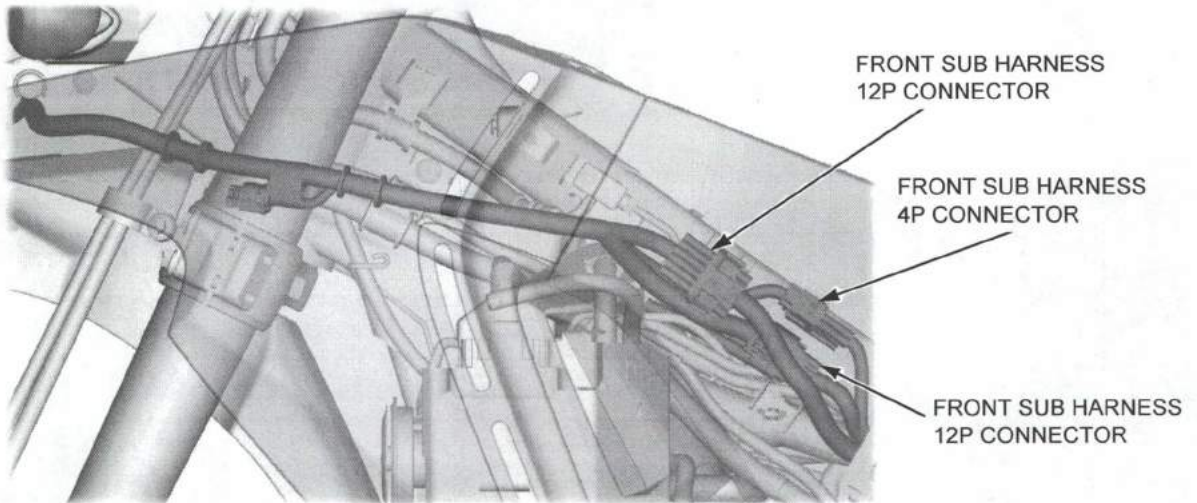
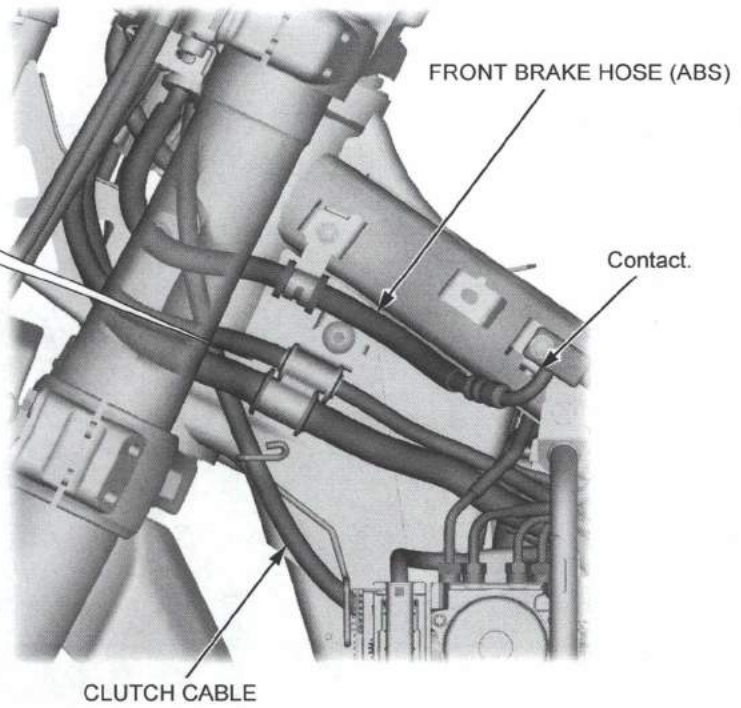
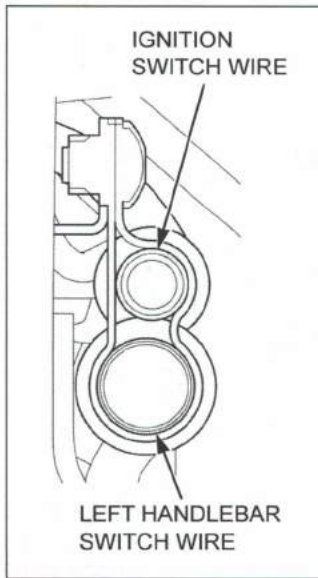



GENERAL INFORMATION

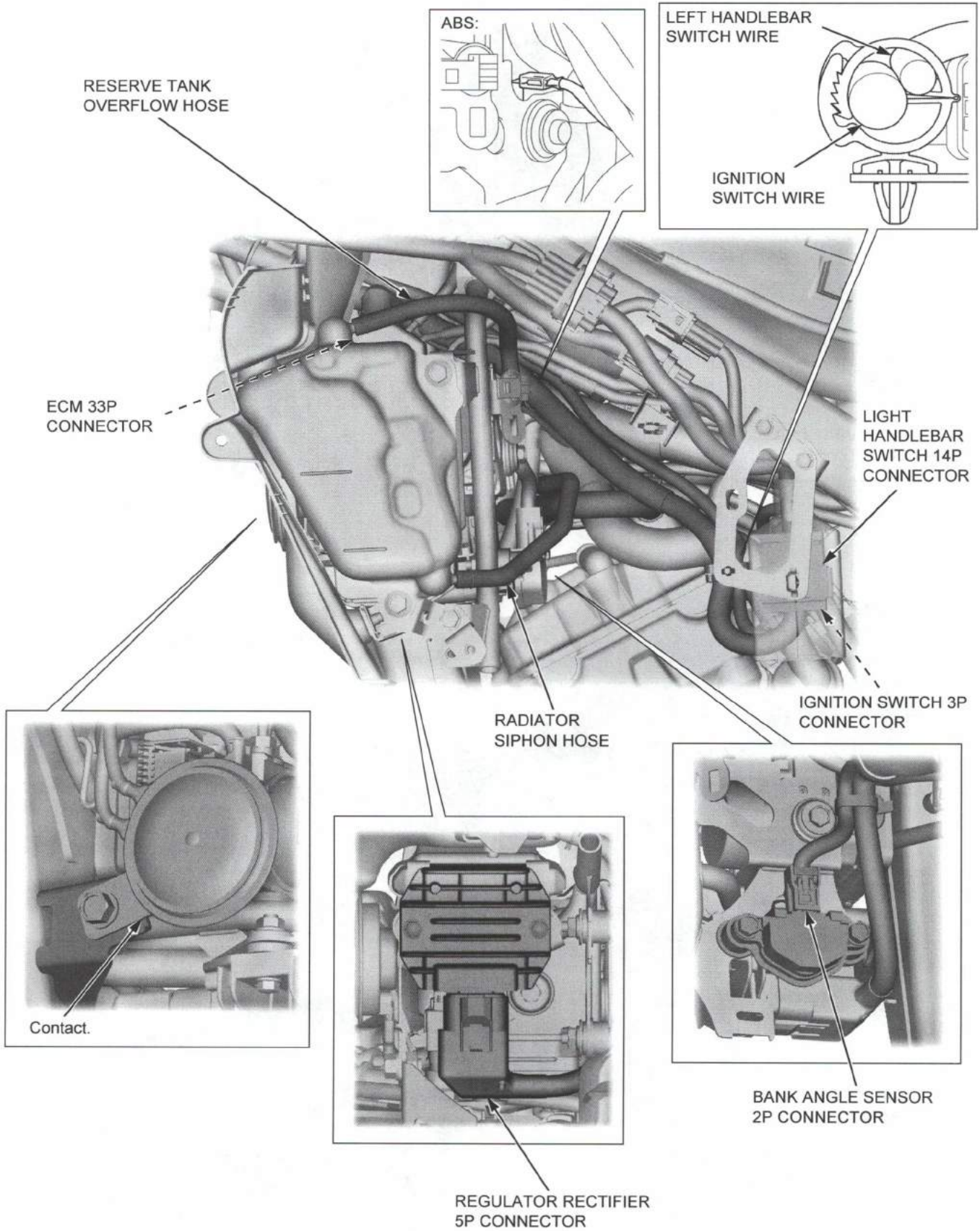

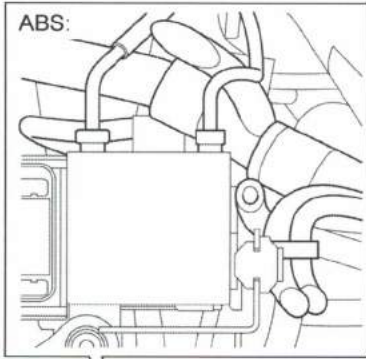

ABS:

RESERVE TANK
OVERFLOW HOSE

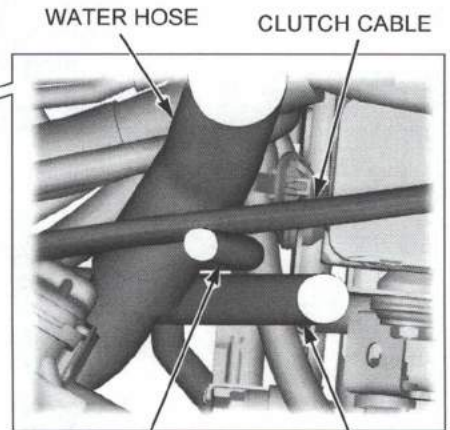
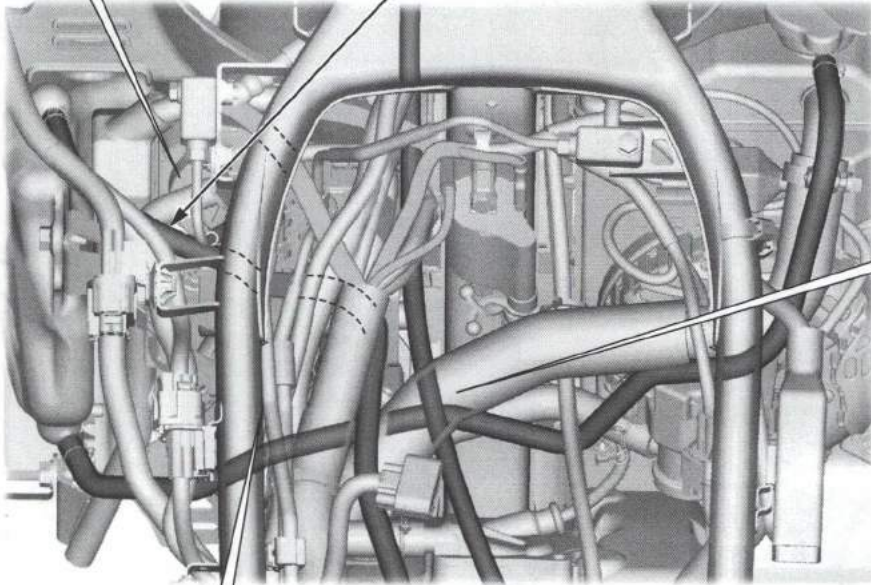

WATER HOSE

CLUTCH CABLE

RADIATOR
SIPHON HOSE

PAIR HOSE

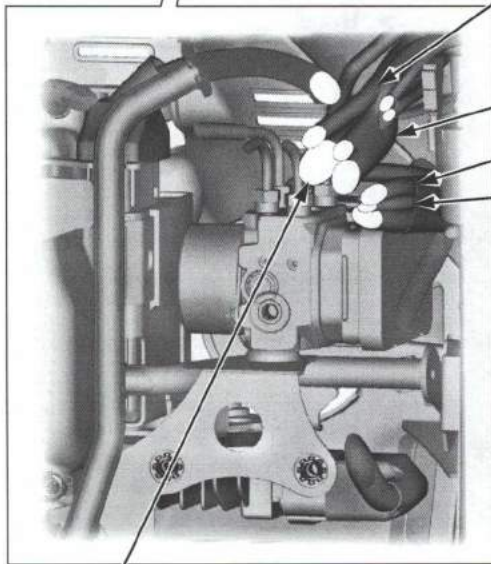

IGNITION
SWITCH WIRE

ECM WIRE

HORN WIRE

ABS MODULATOR WIRE

LEFT HANDLEBAR
SWITCH WIRE

IGNITION COIL
WIRE CONNECTOR
(Straight type)

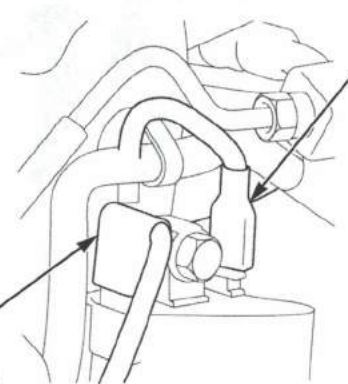

IGNITION COIL
WIRE CONNECTOR
(L type)

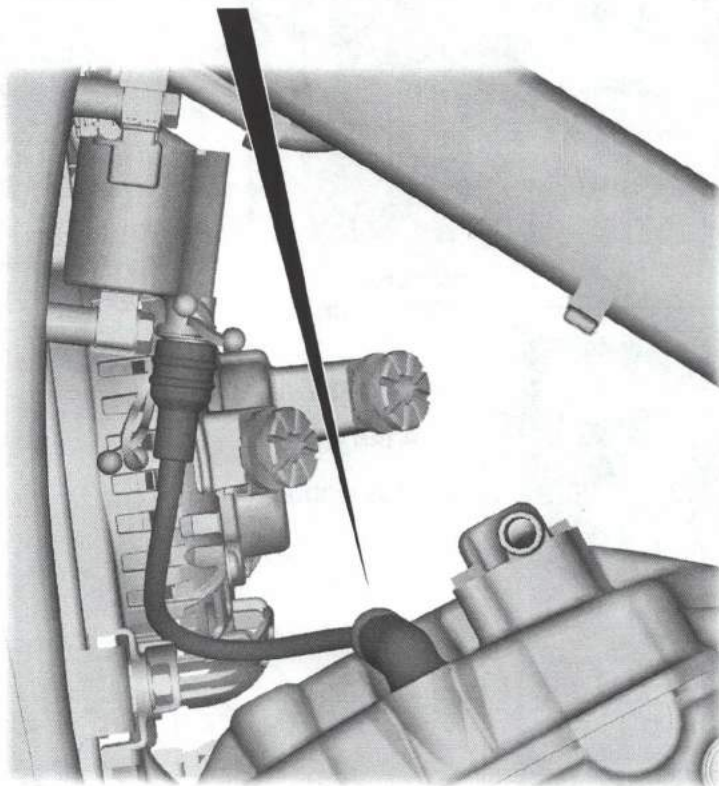
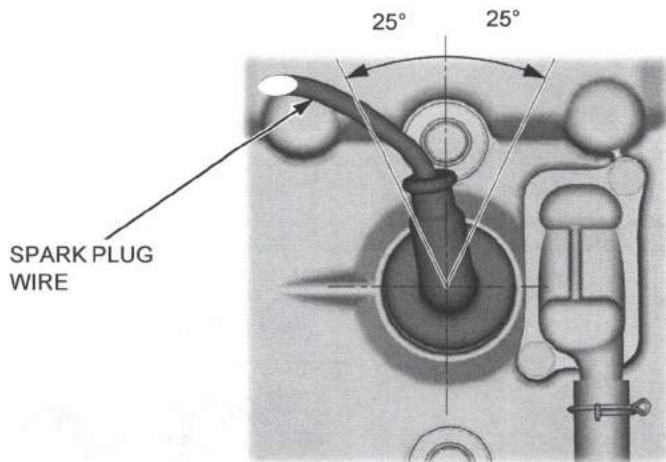

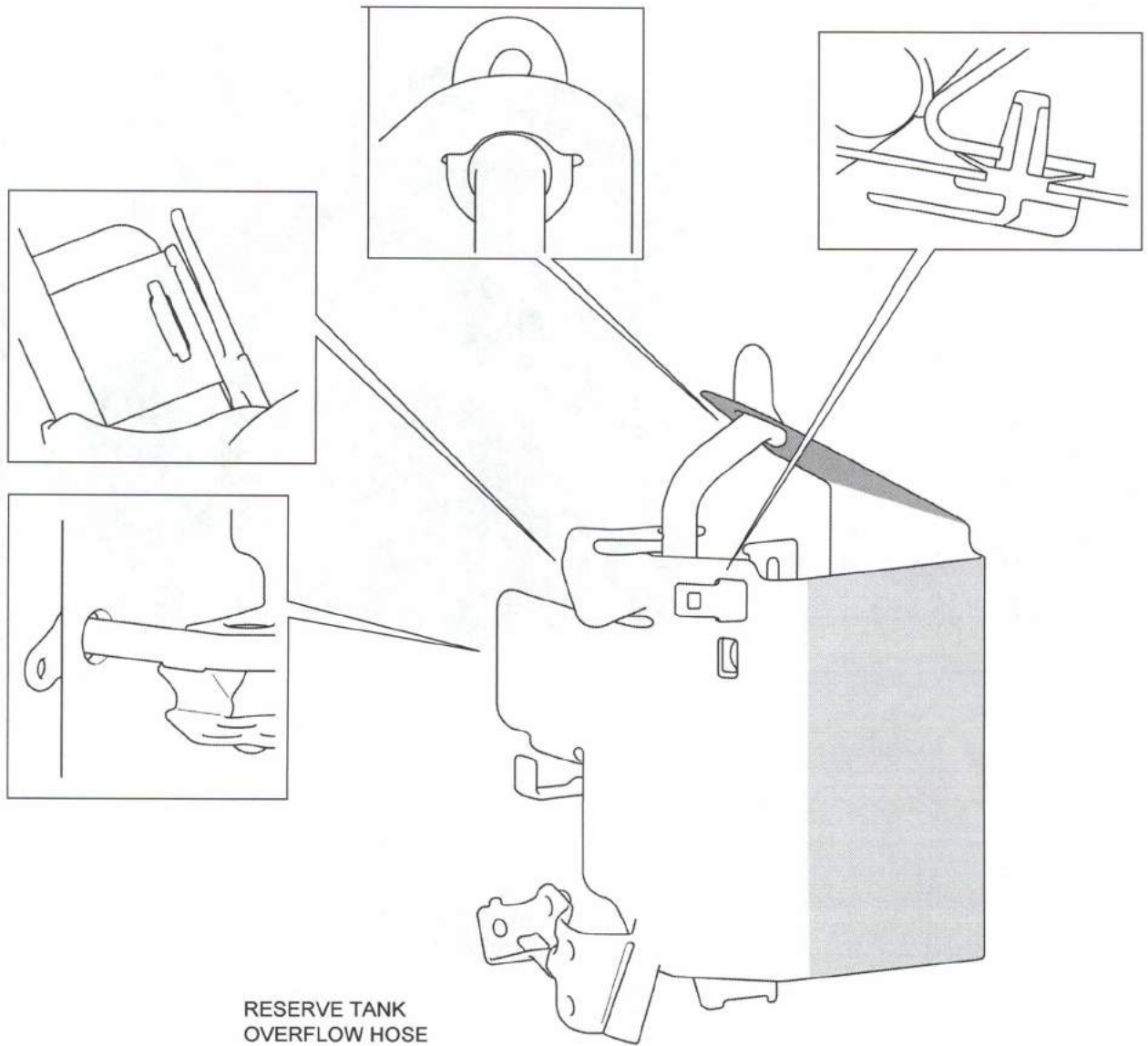

RESERVE TANK
OVERFLOW HOSE

IGNITION
SWITCH WIRE

WIRE HARNESS

LEFT HANDLEBAR
SWITCH WIRE

RADIATOR
SIPHON HOSE

PAIR HOSE

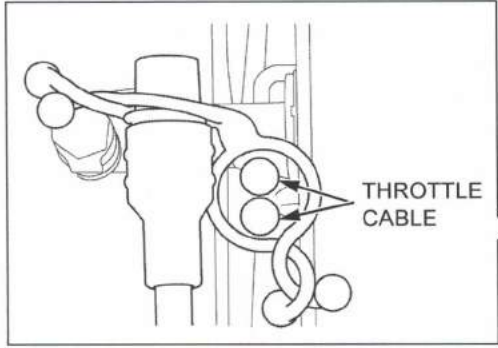
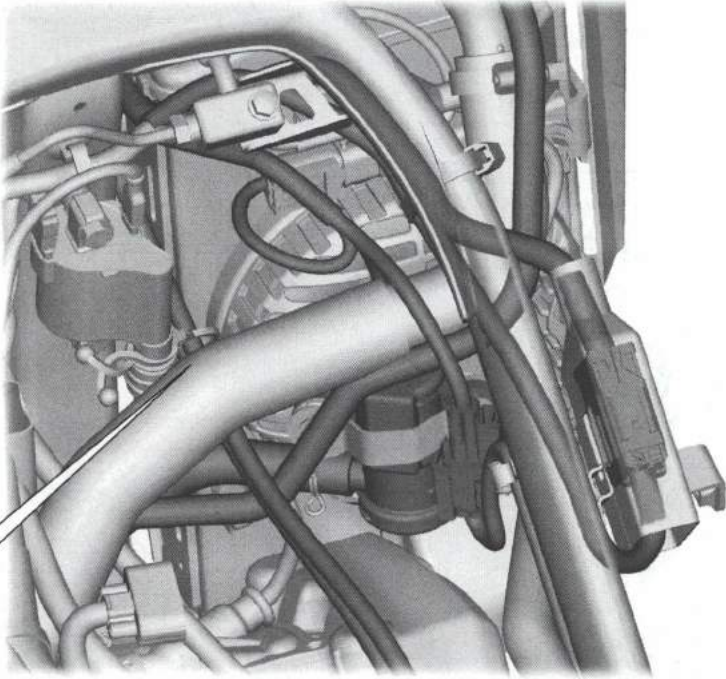

RESERVE TANK OVERFLOW HOSE

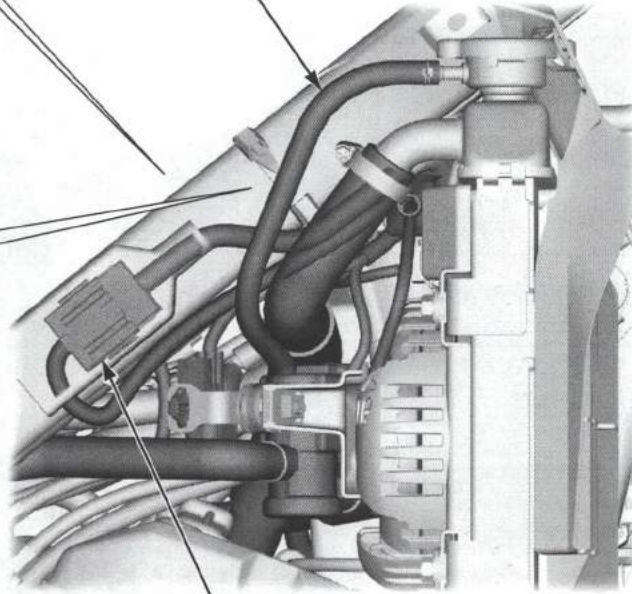

RIGHT HANDLEBAR SWITCH 10P CONNECTOR

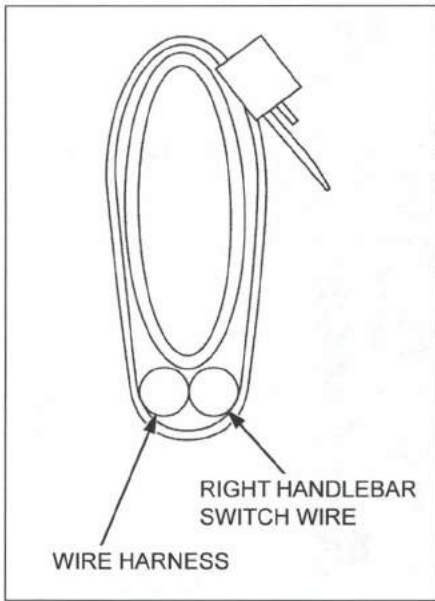

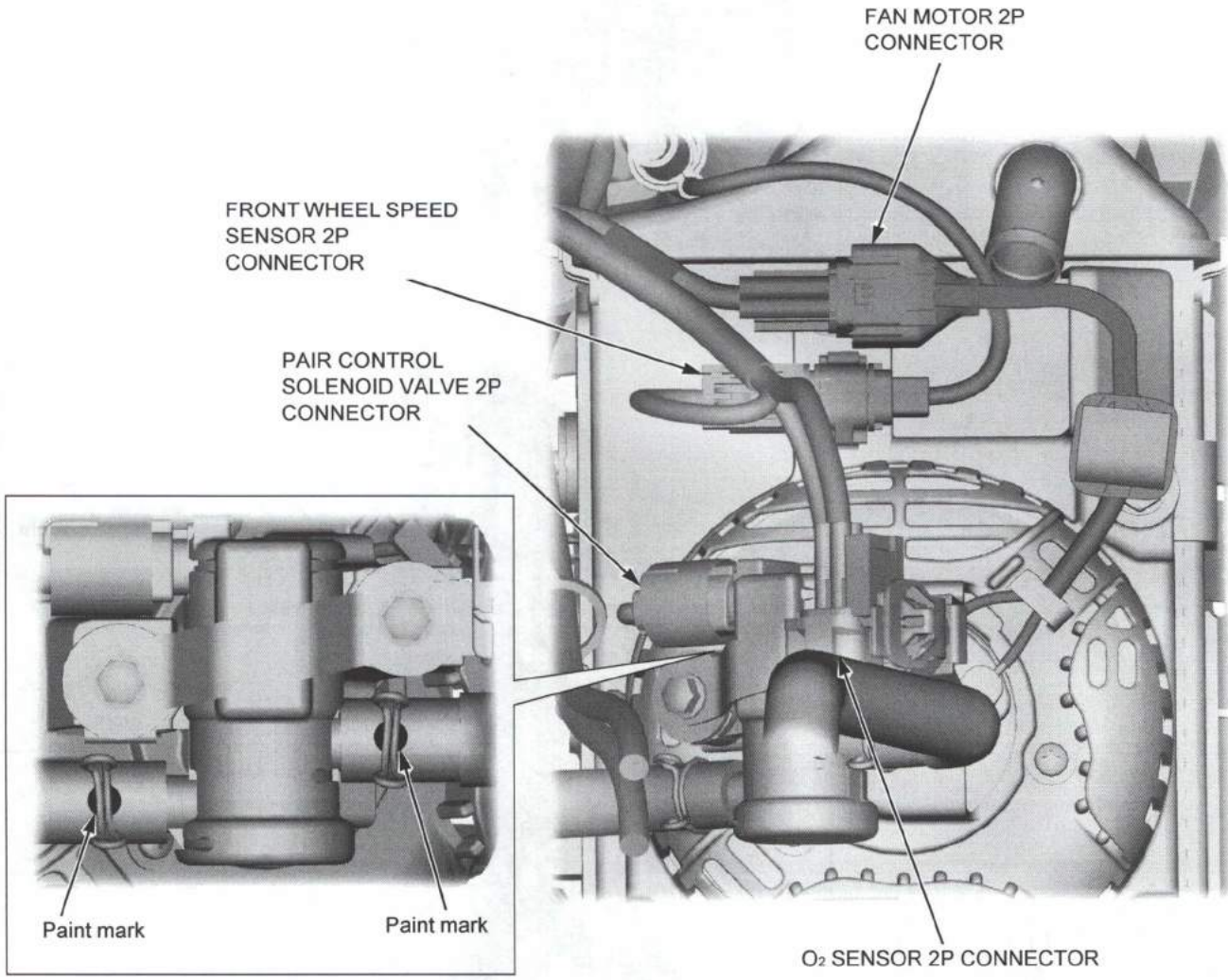



GENERAL INFORMATION

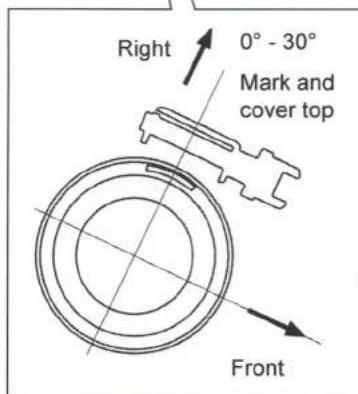
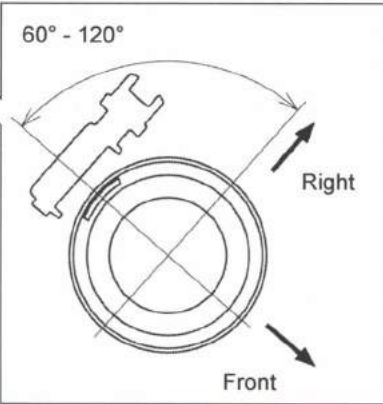
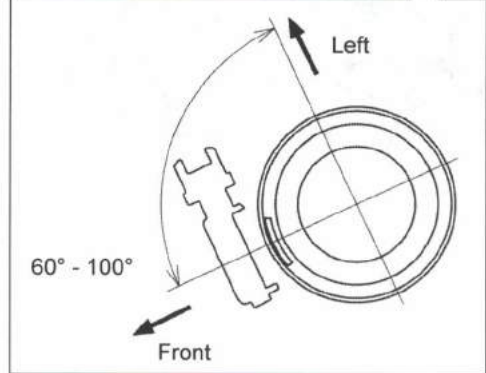
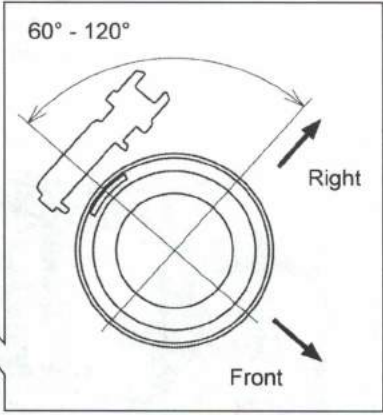
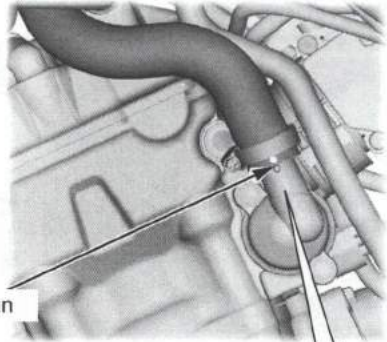
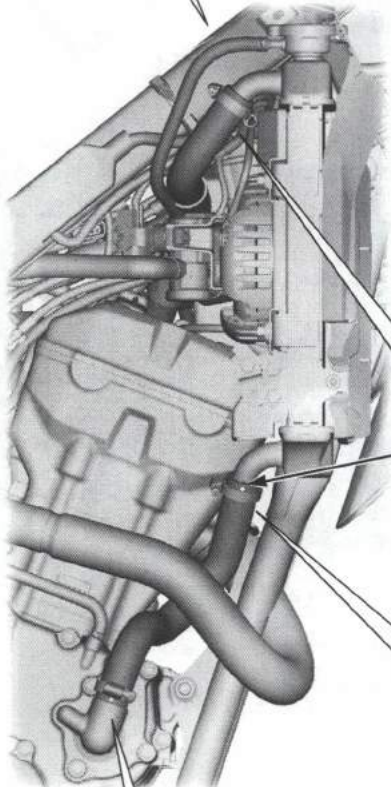
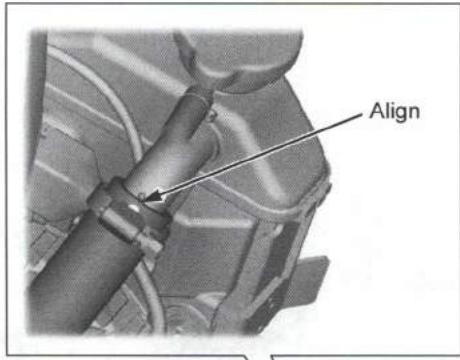

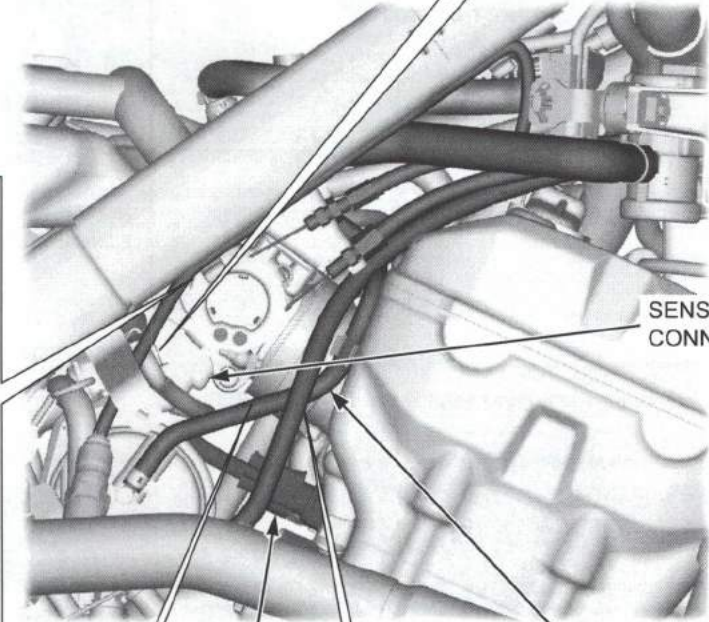
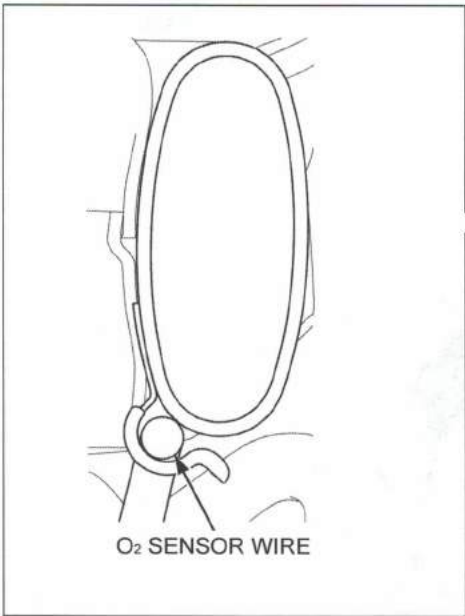
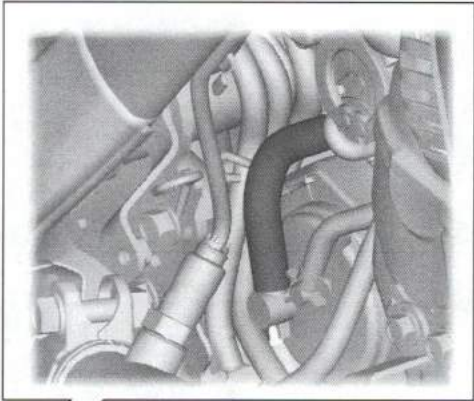

SENSOR UNIT 5P CONNECTOR

FUEL TANK -to- EVAP CANISTER HOSE (EVAP)

ECT SENSOR 3P CONNECTOR

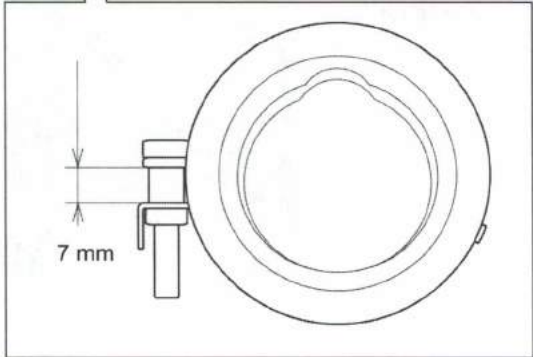
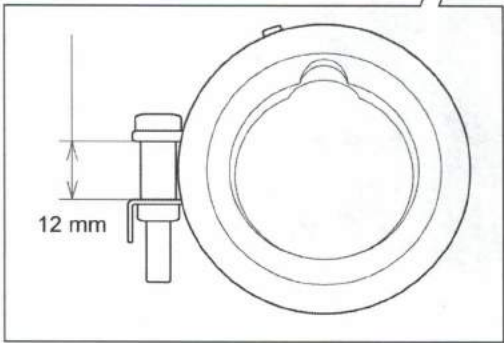



GENERAL INFORMATION

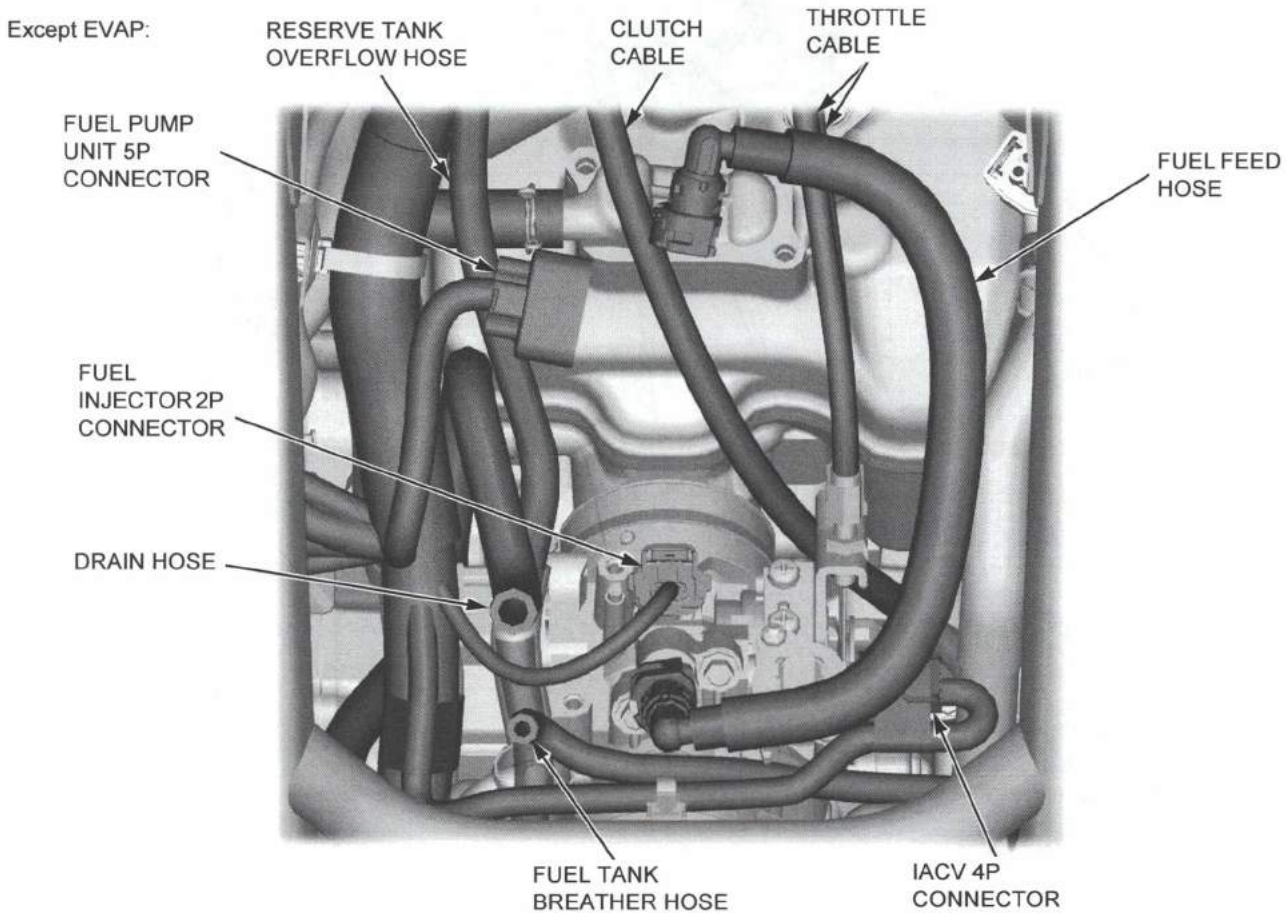
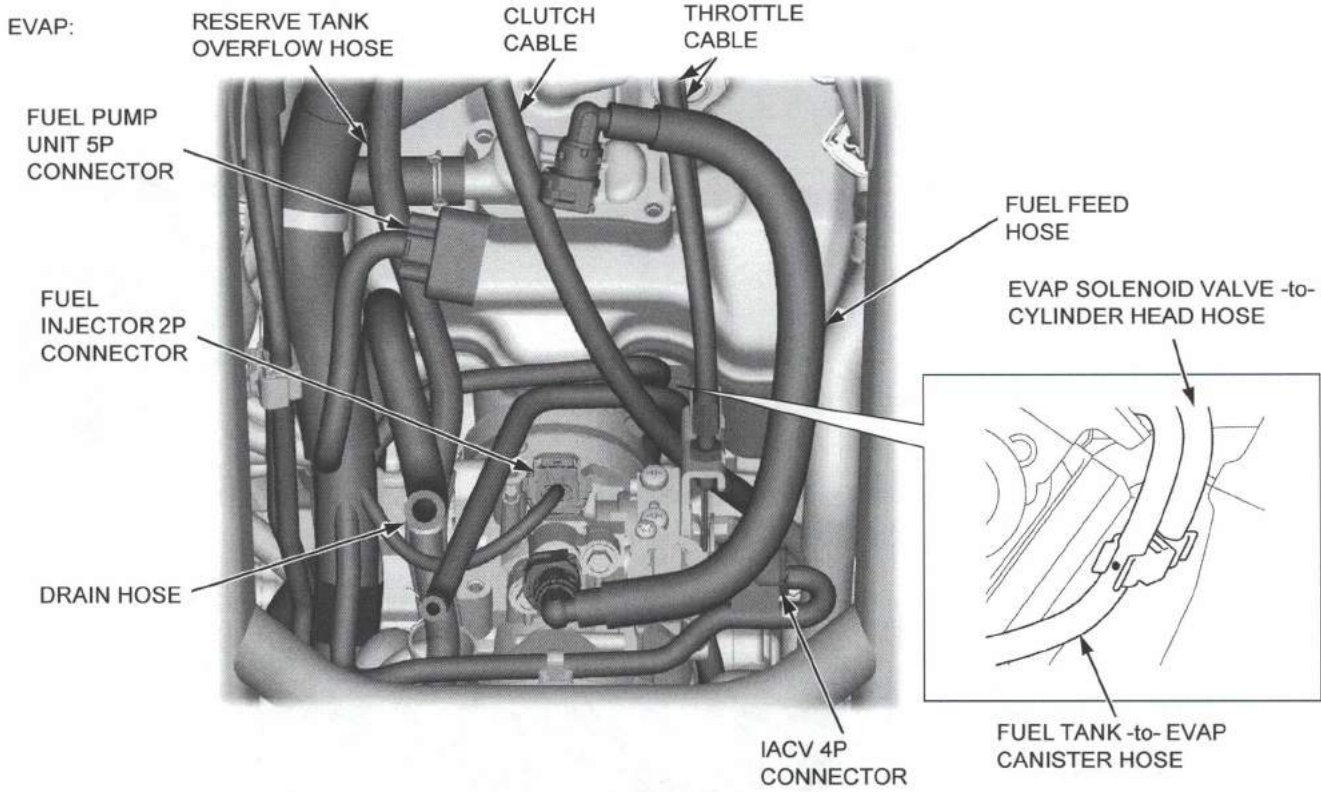



FUEL PUMP
UNIT 5P
CONNECTOR

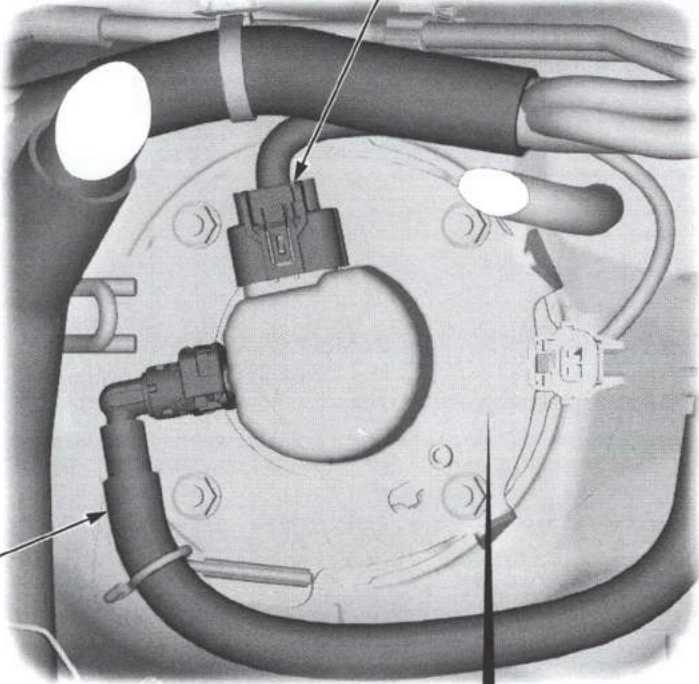

FUEL FEED
HOSE

Apply
engine oil
13 mm

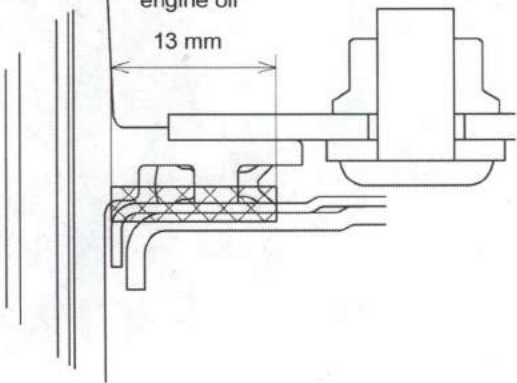



GENERAL INFORMATION

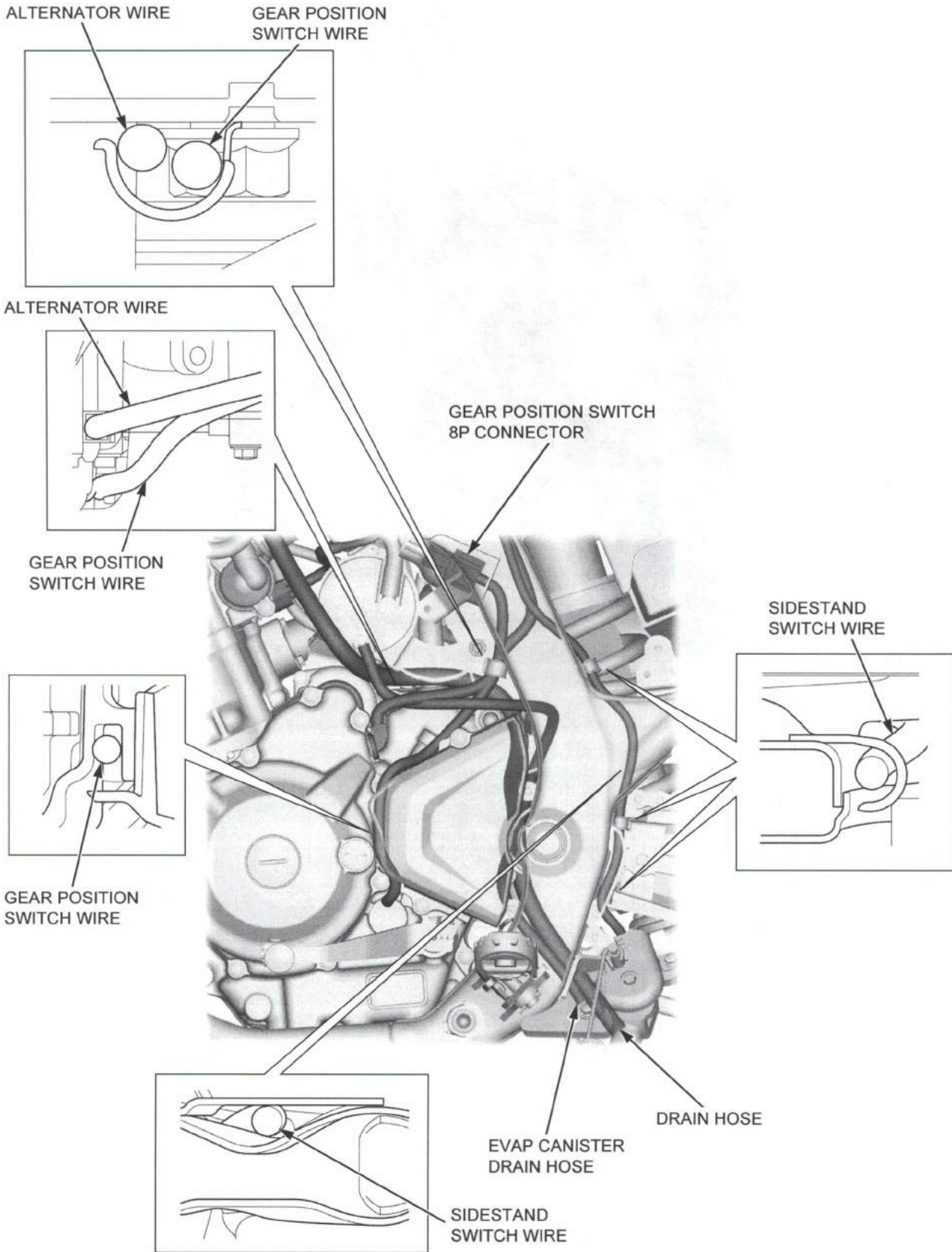

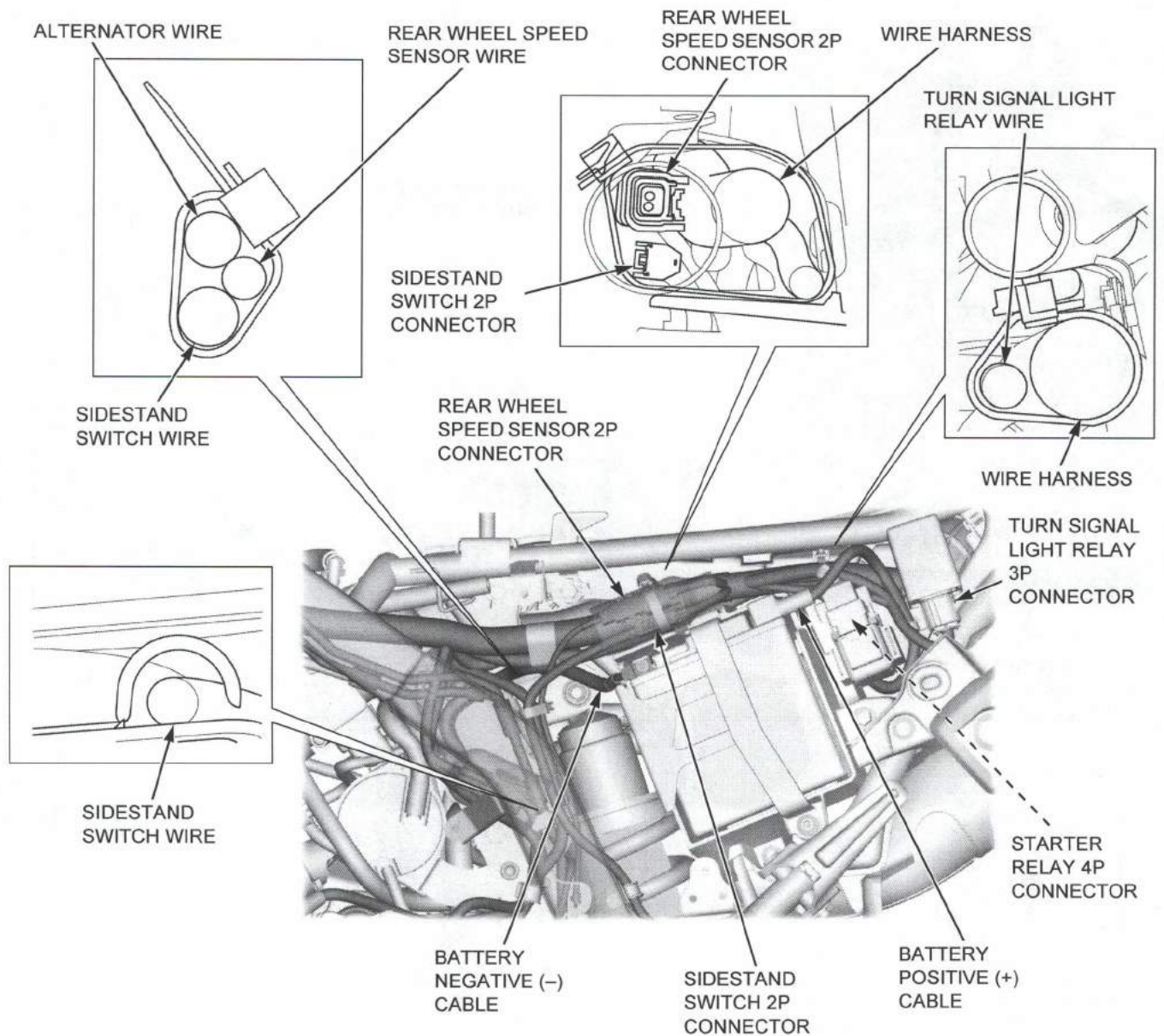



GENERAL INFORMATION

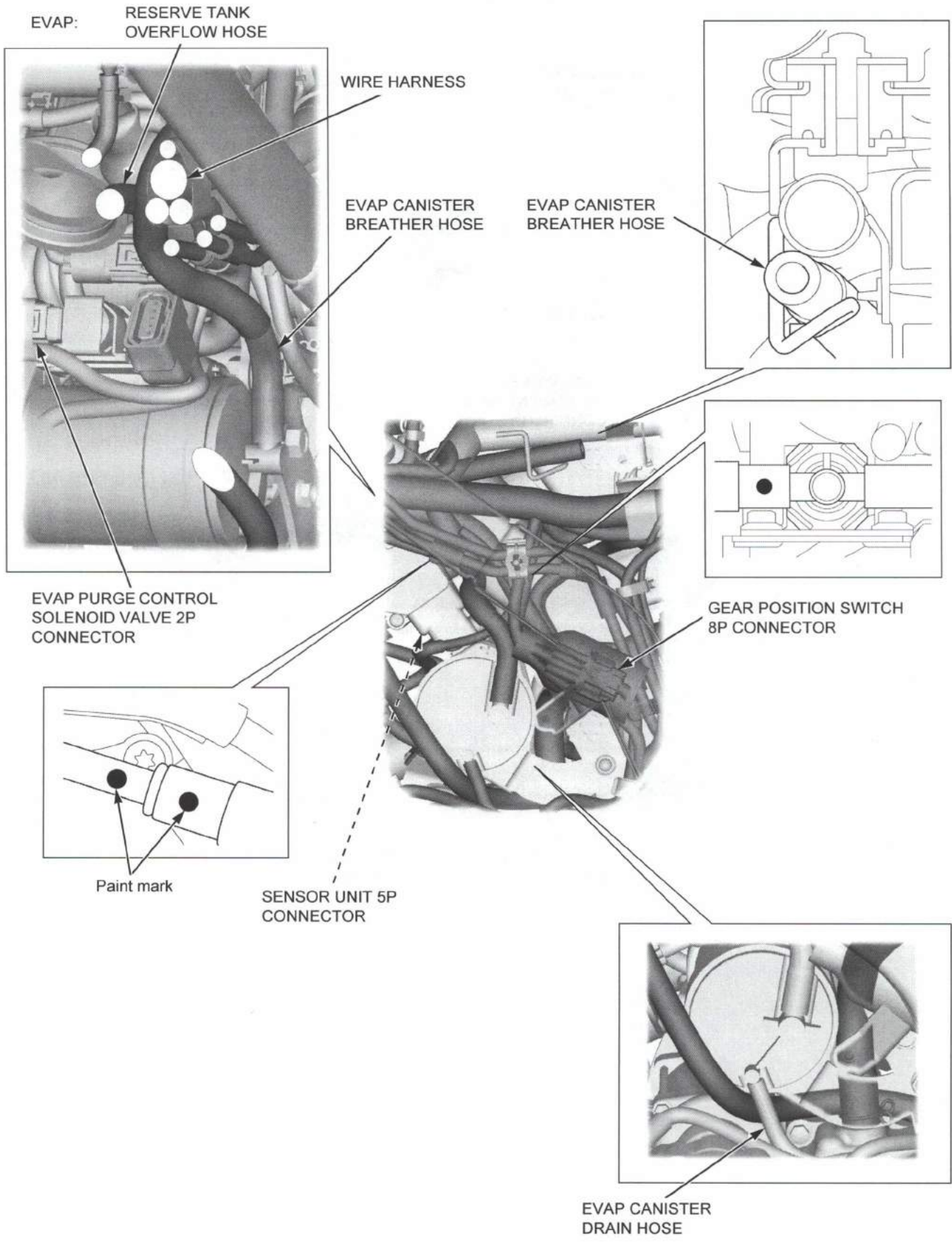



Except EVAP:

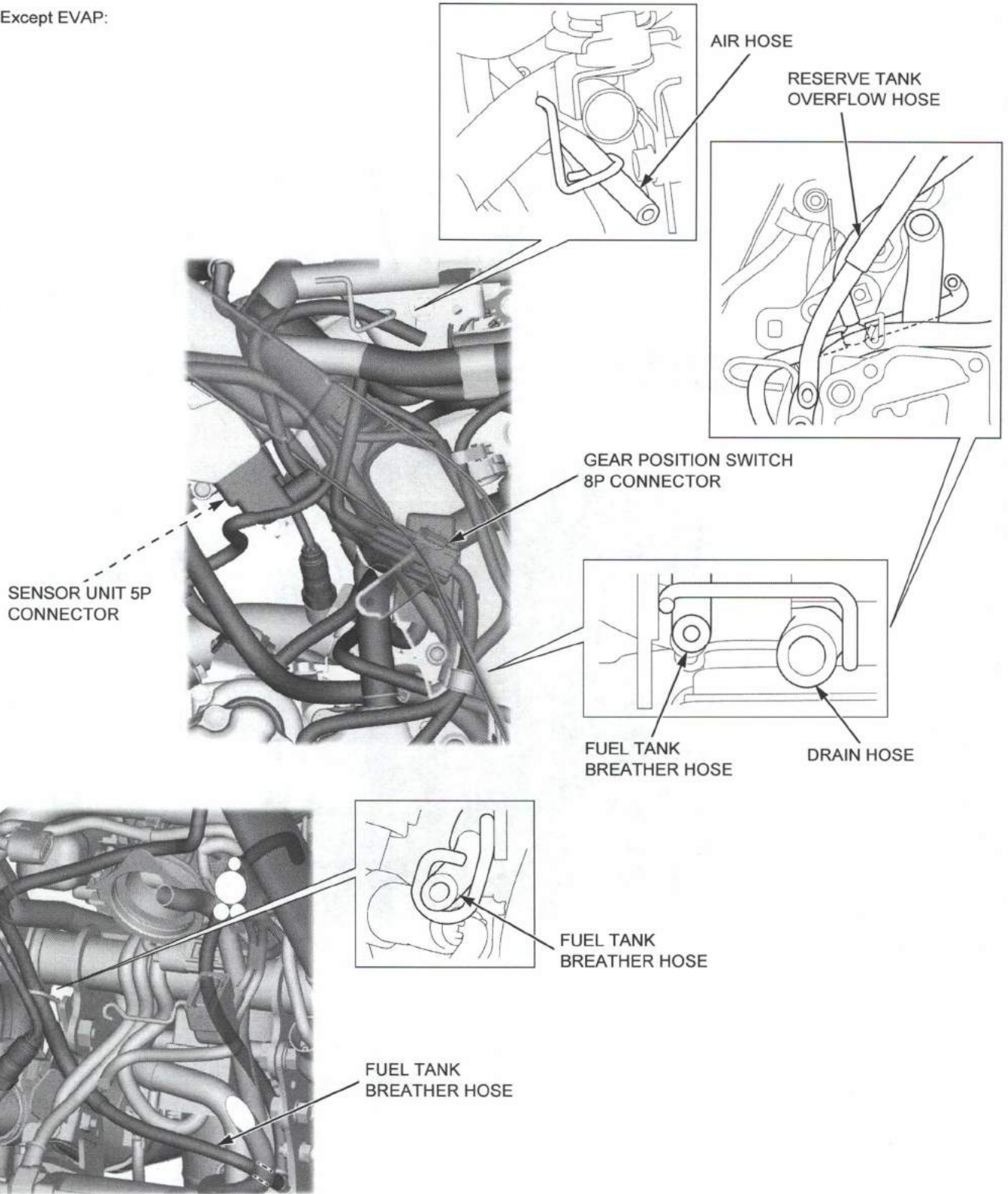

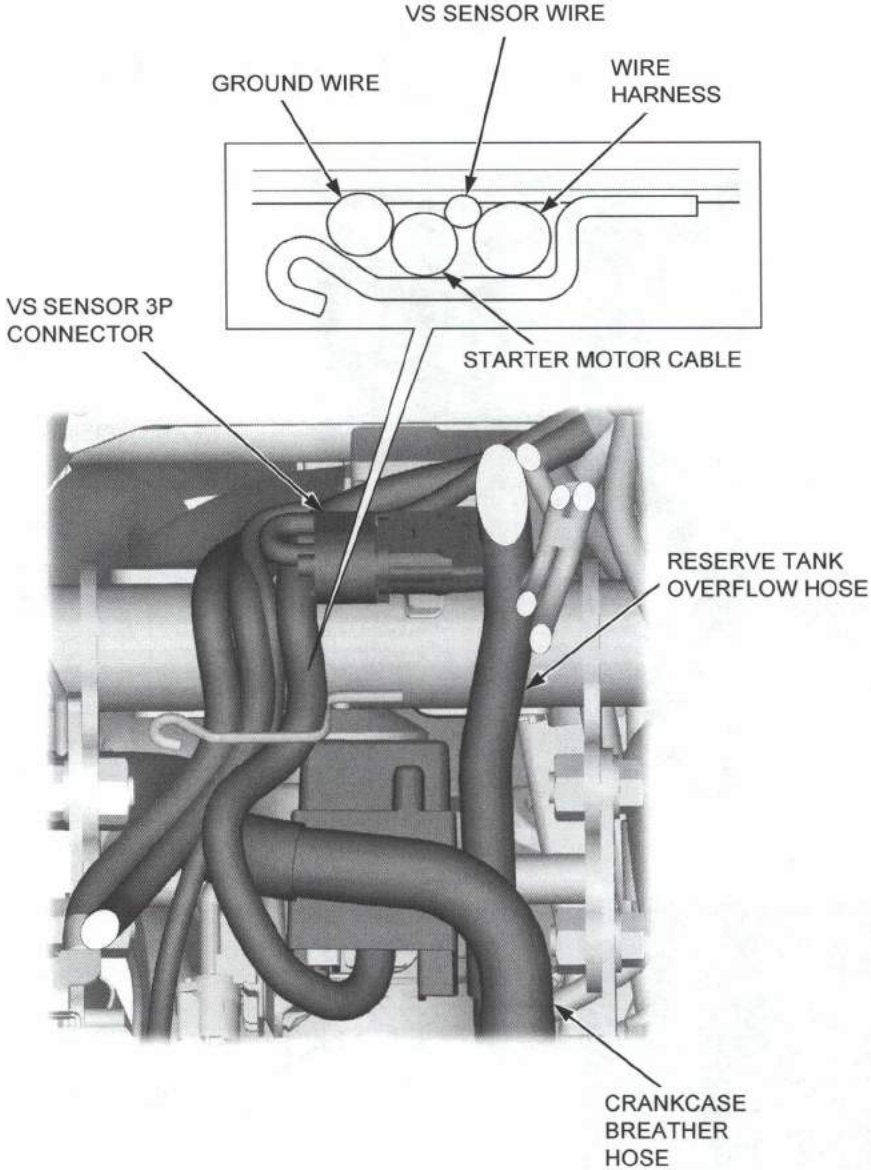



ABS:

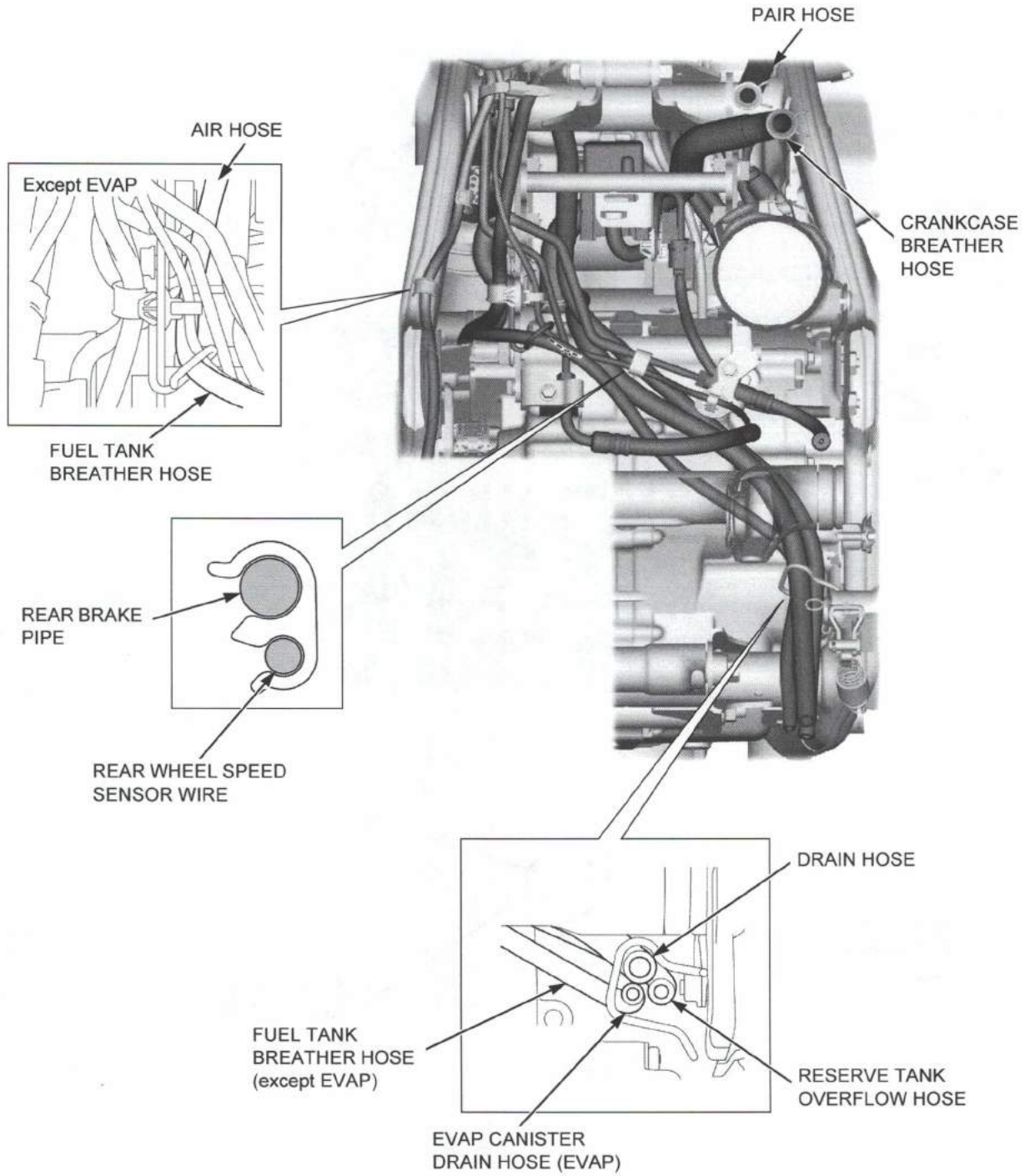



GENERAL INFORMATION

Except ABS:

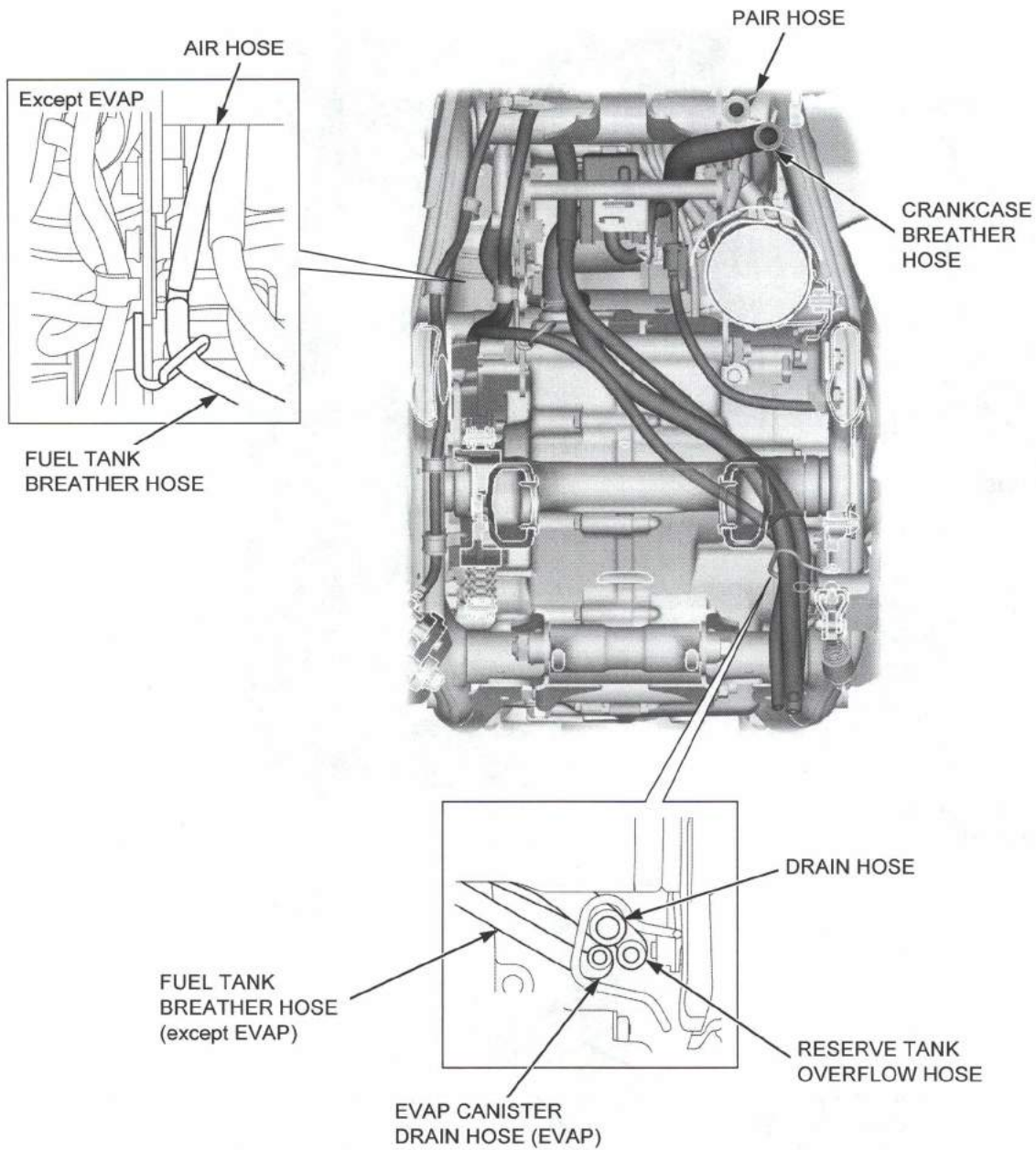

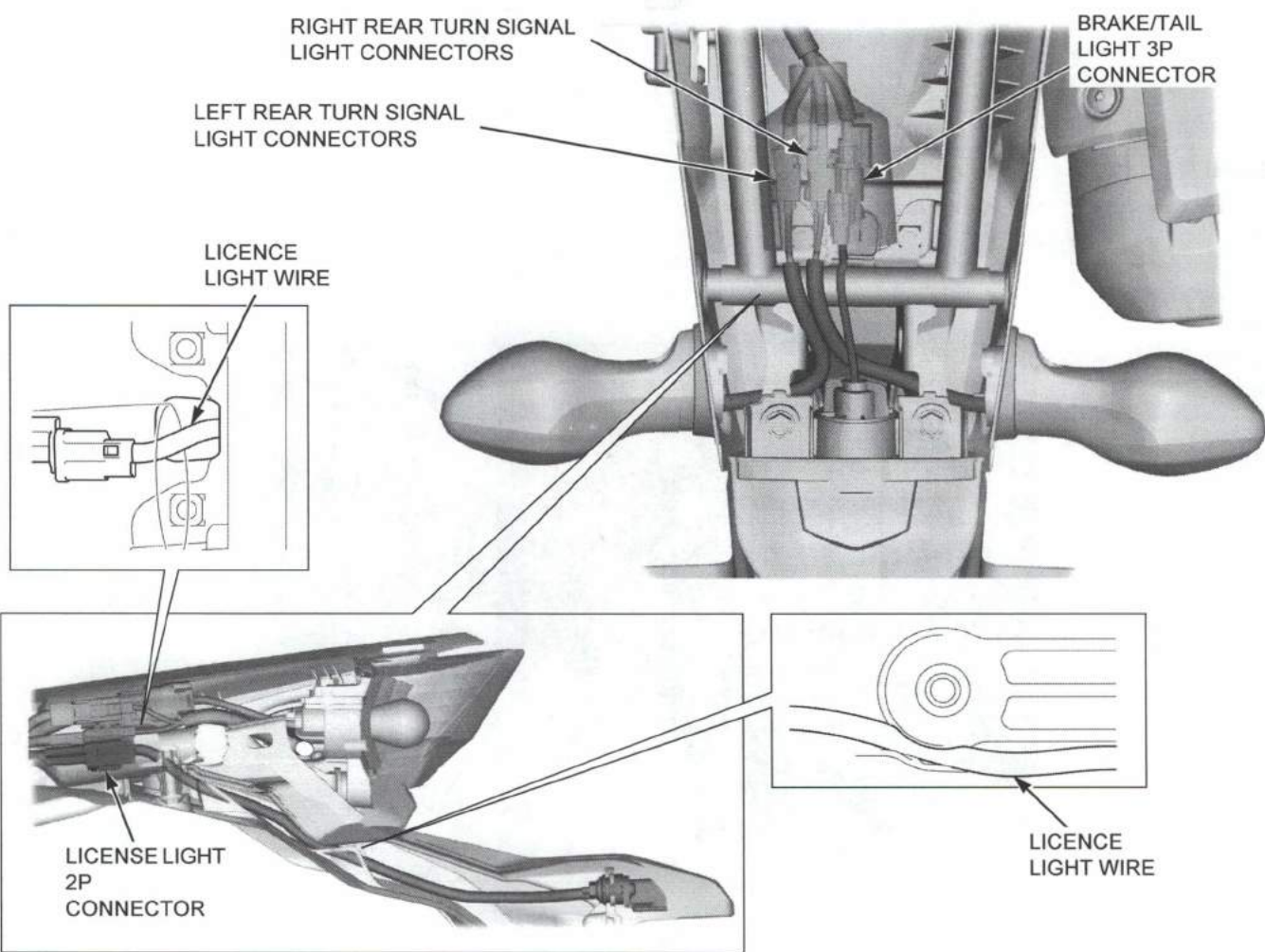
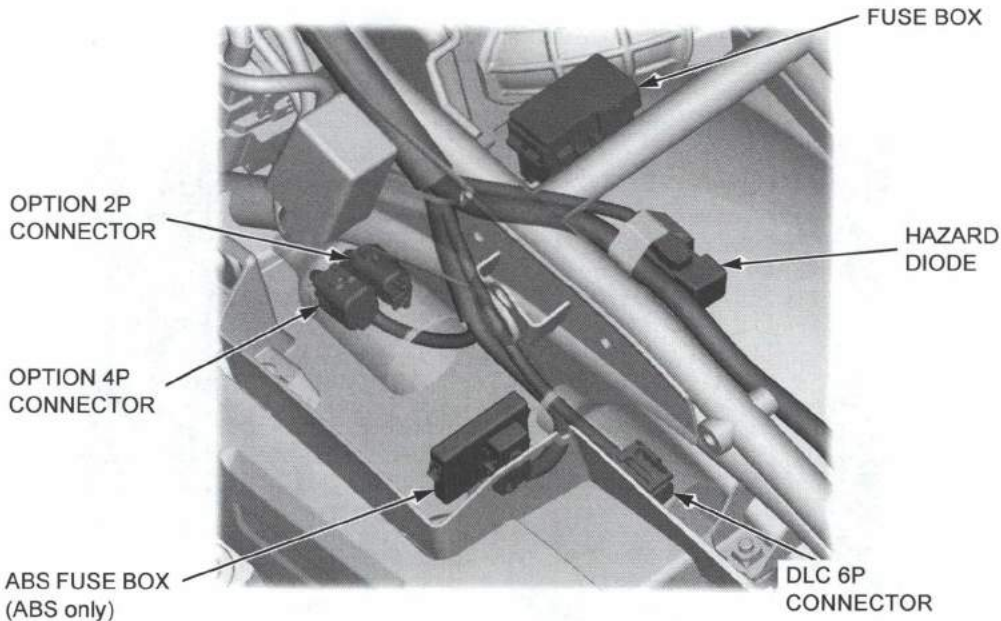



GENERAL INFORMATION

ABS:

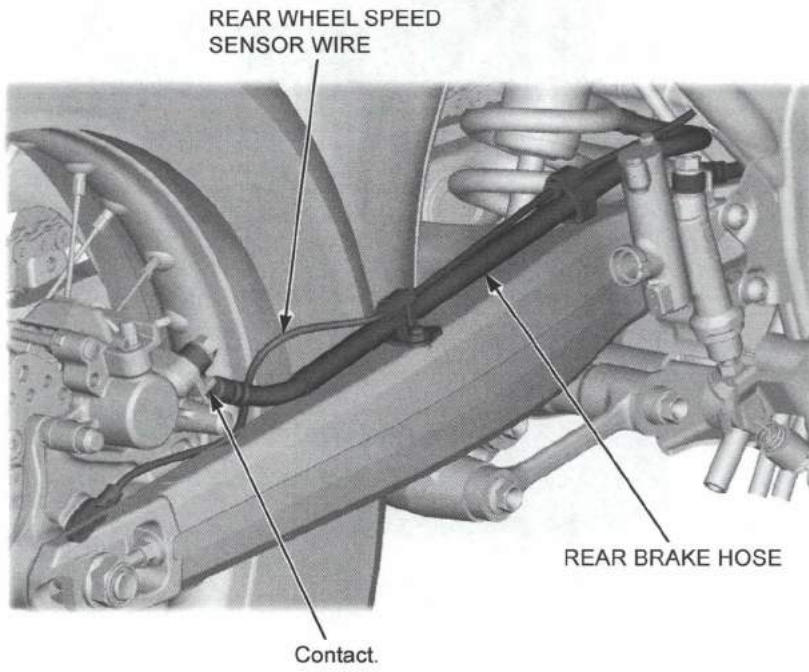

Except ABS:

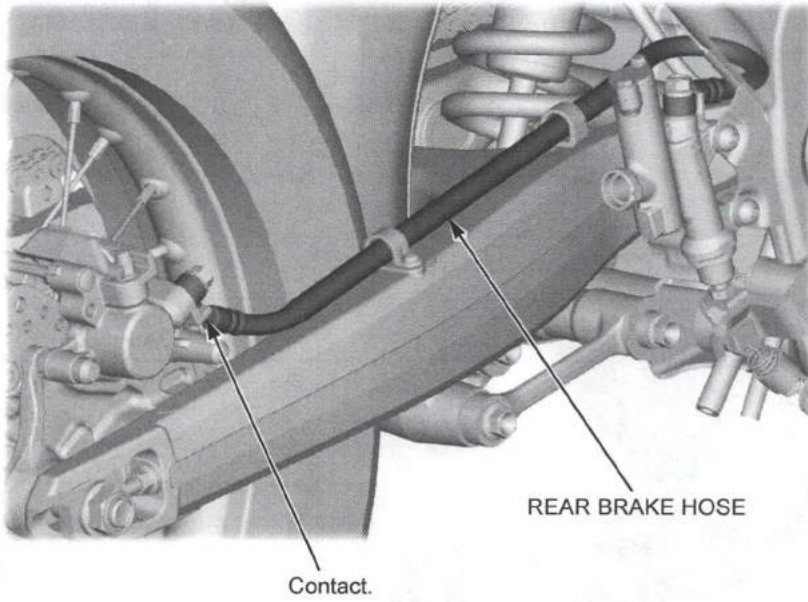



Standard type:

Refer to the rally type except for the standard type illustrations

ABS:

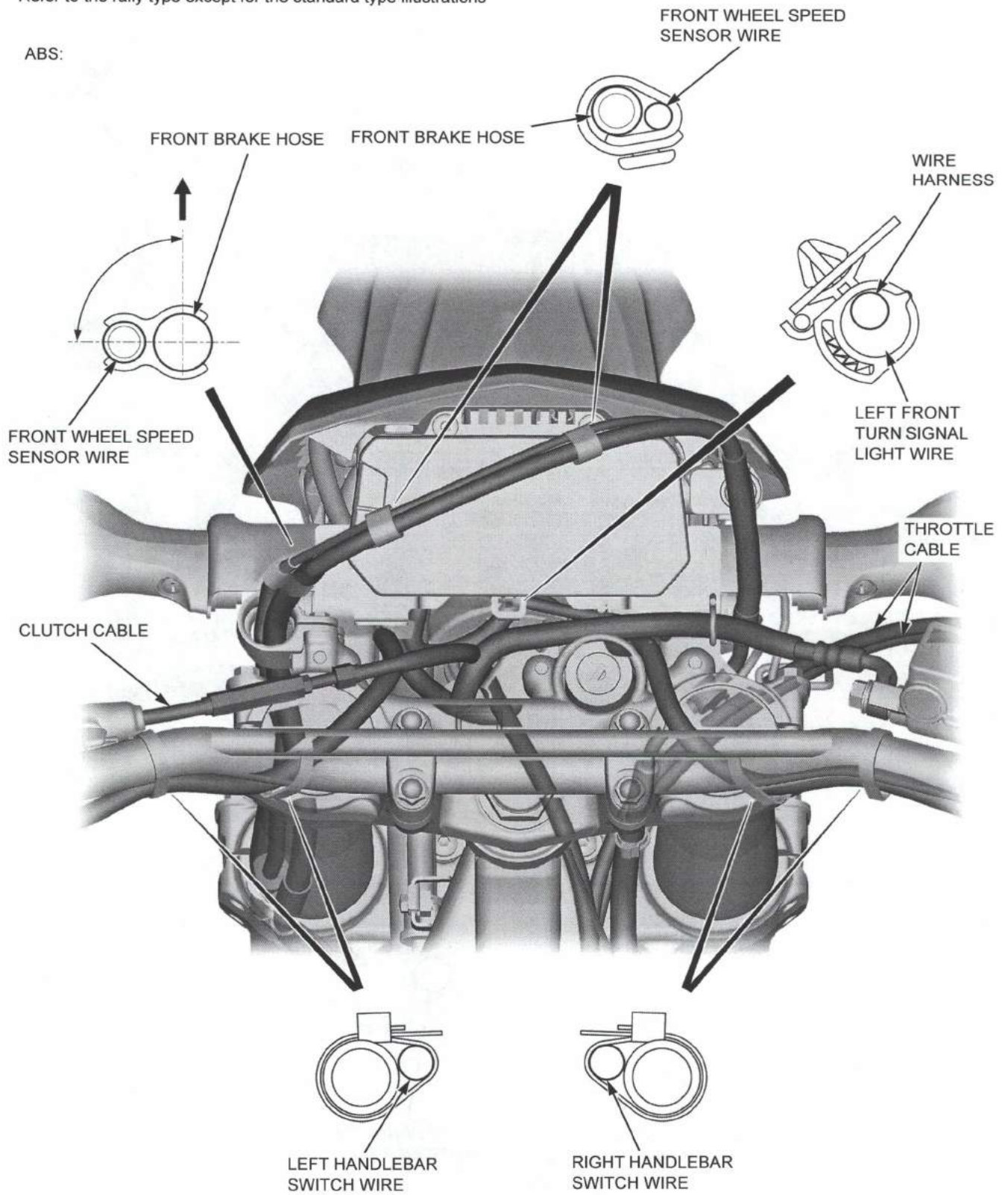



GENERAL INFORMATION

Except ABS:

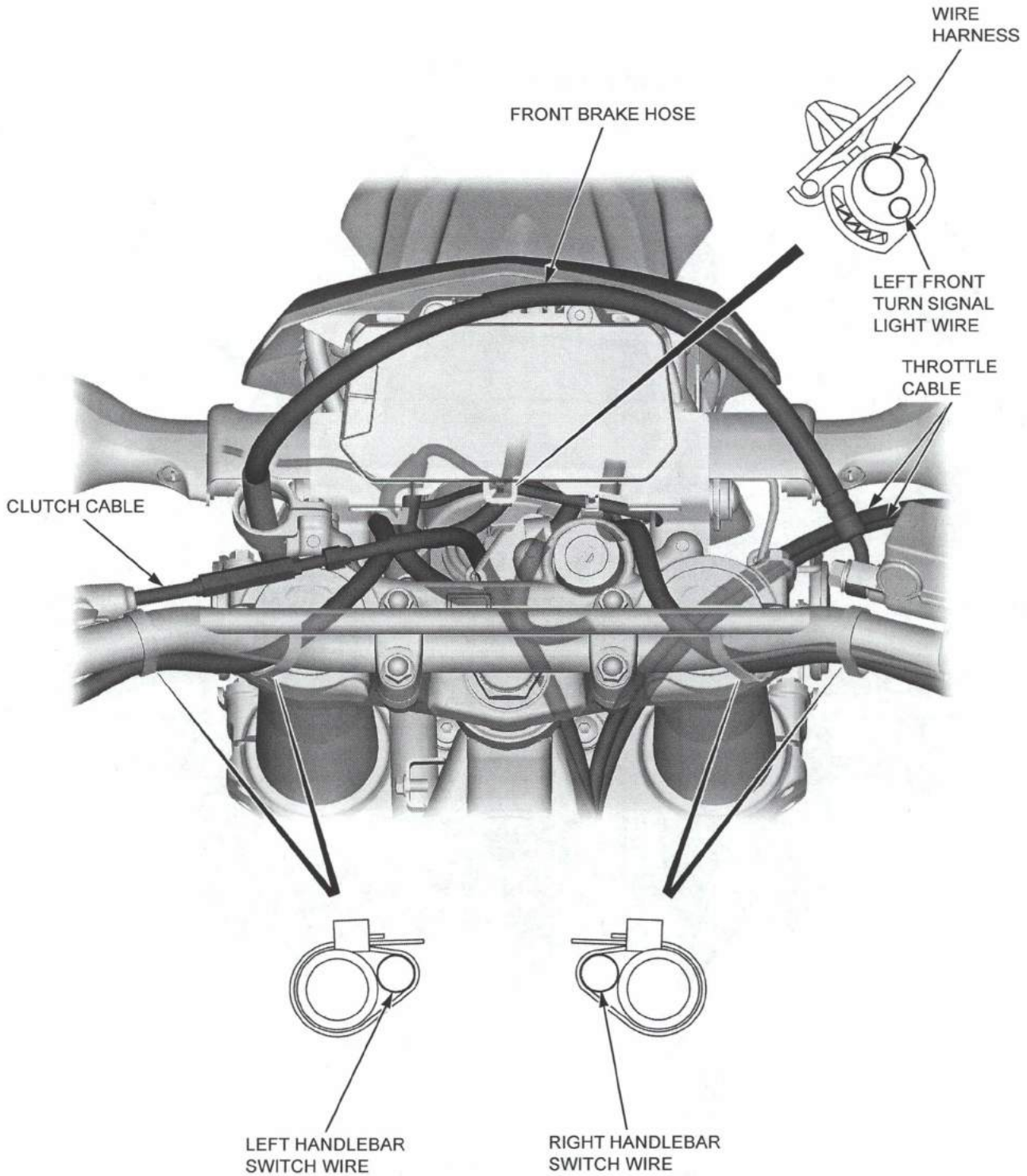

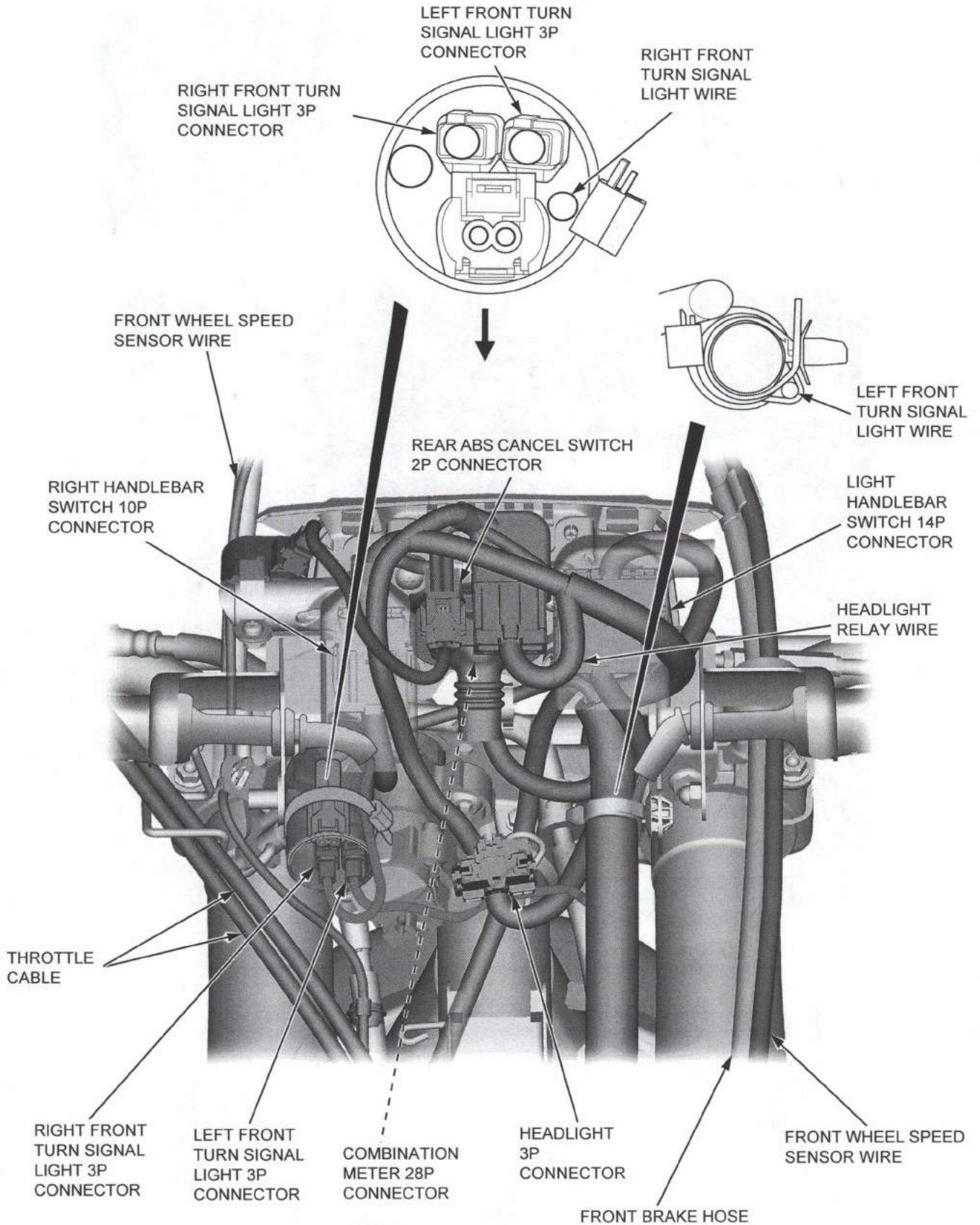



GENERAL INFORMATION

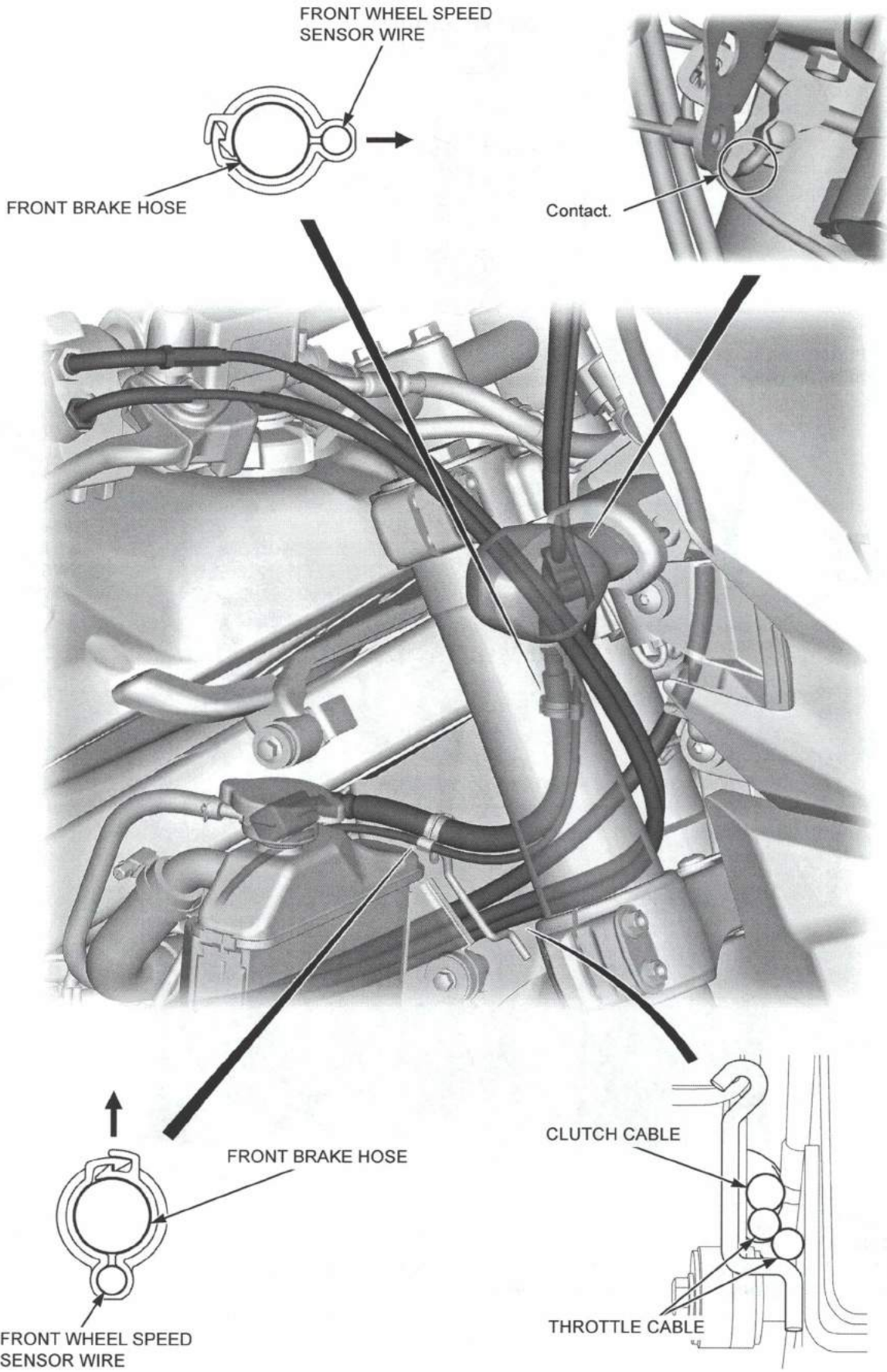

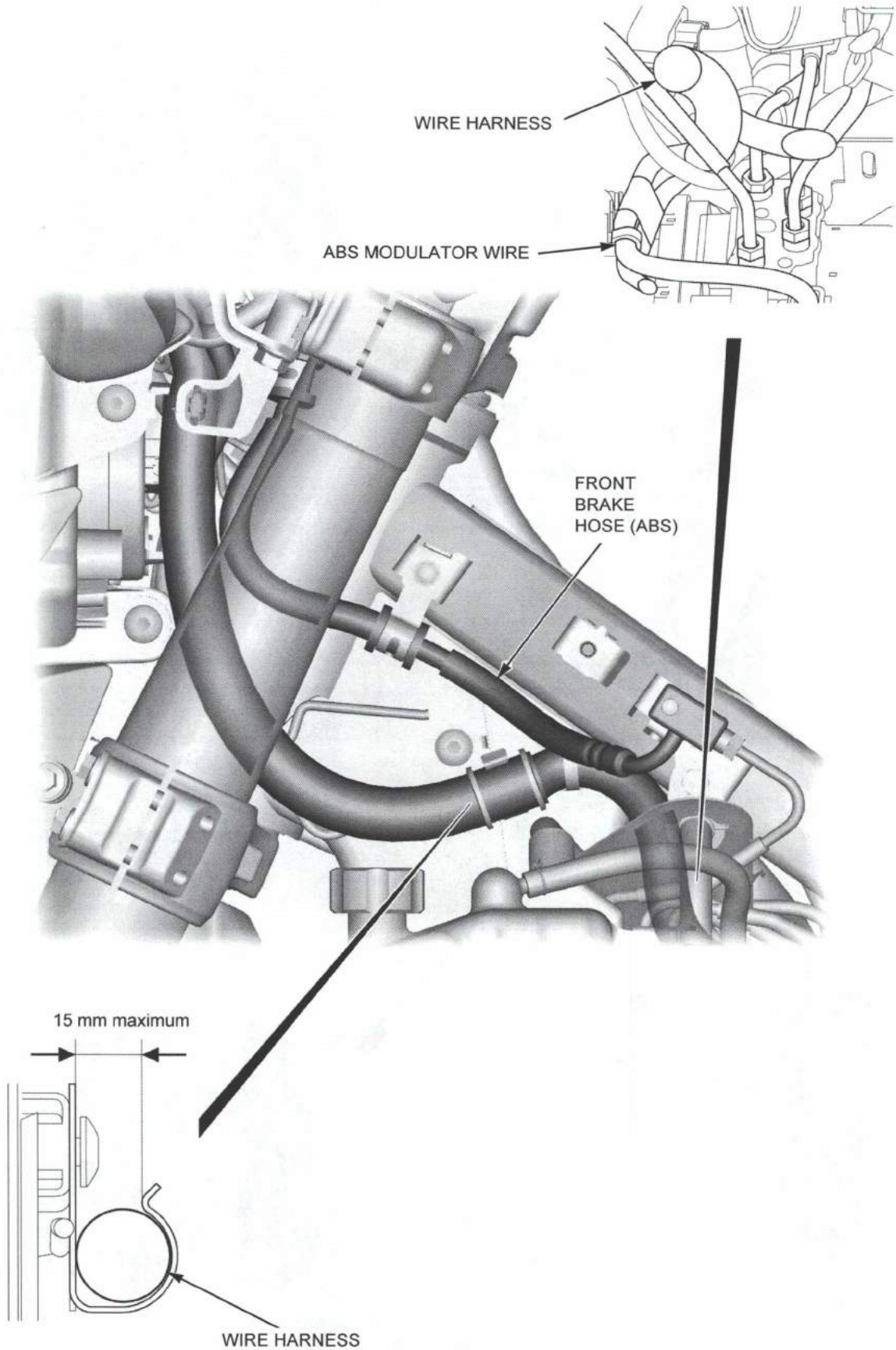



GENERAL INFORMATION

BANK ANGLE SENSOR
2P (Black) CONNECTOR

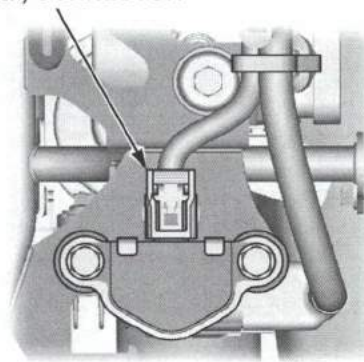

RESERVE TANK
OVERFLOW HOSE

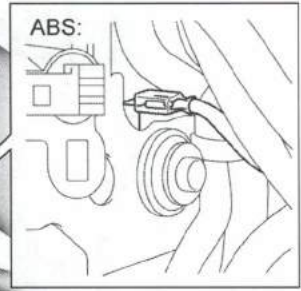
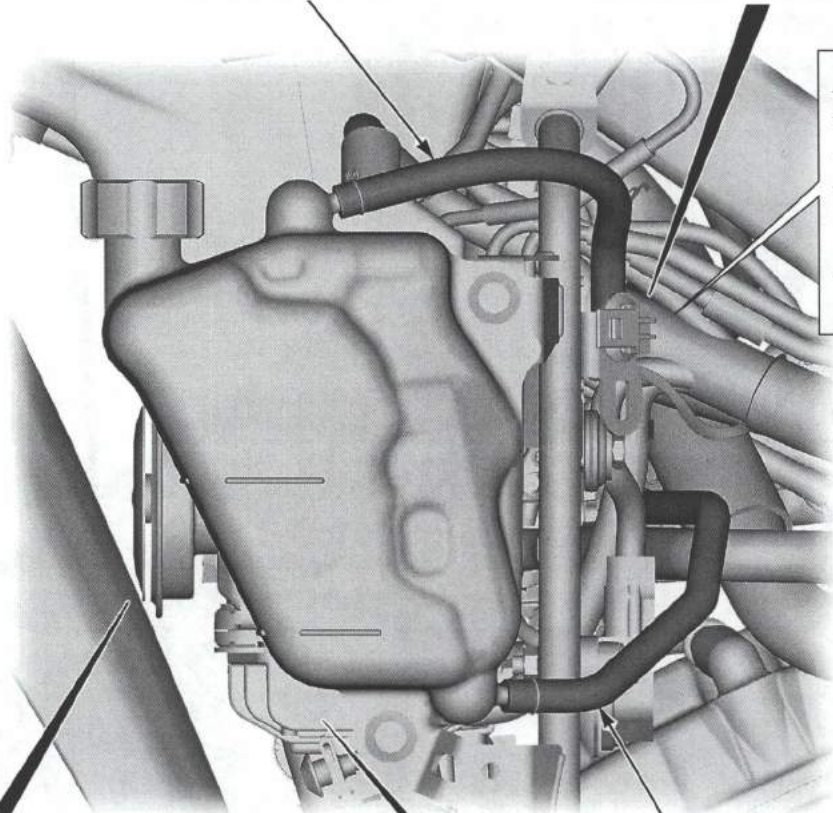

RADIATOR
SIPHON HOSE

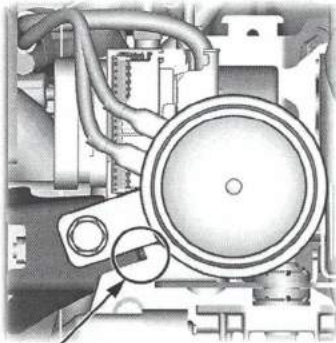

Contact.

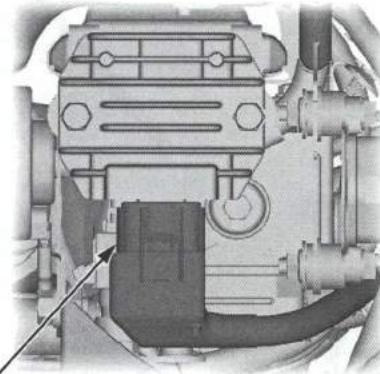

REGULATOR RECTIFIER
5P (Black) CONNECTOR

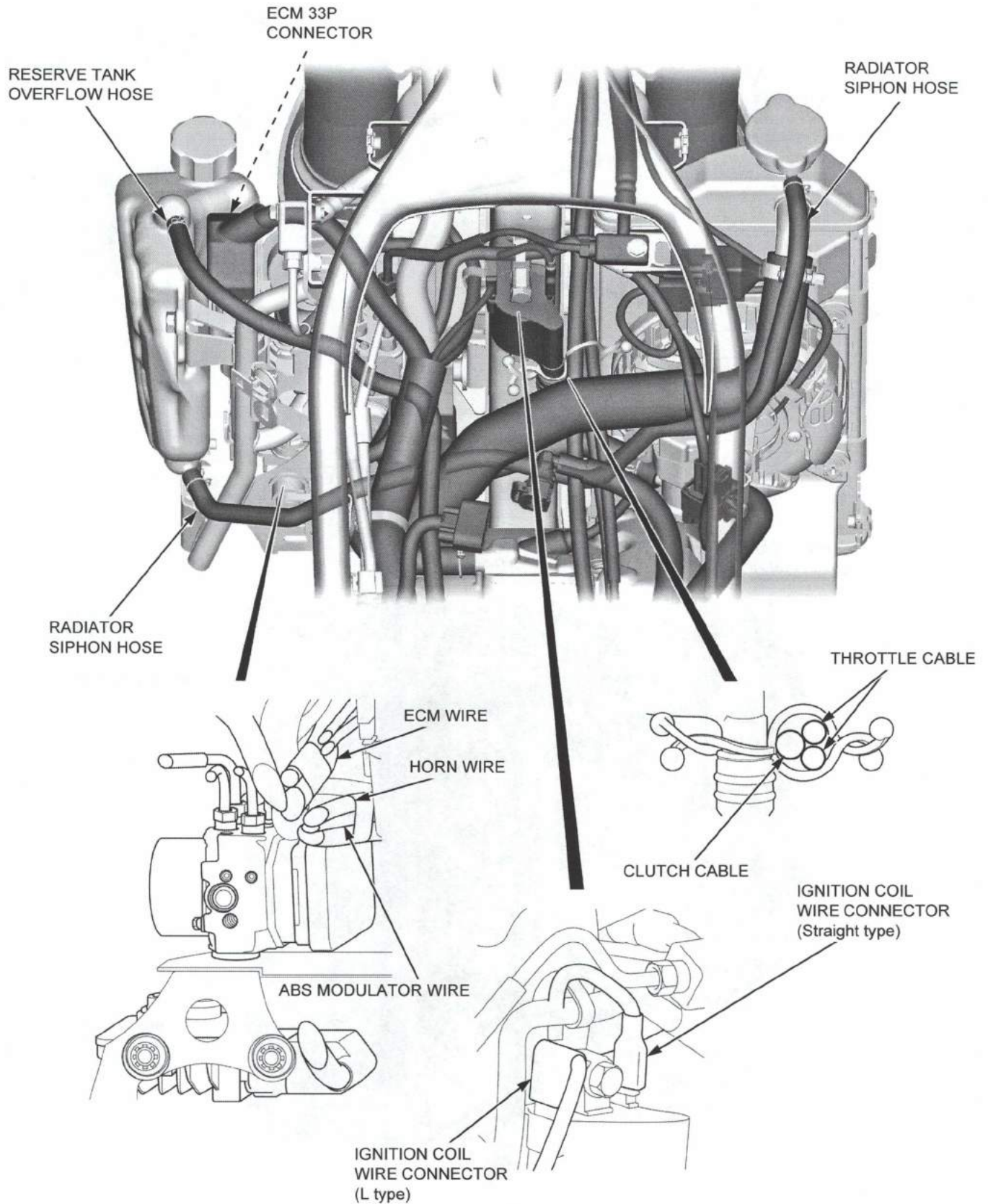



GENERAL INFORMATION

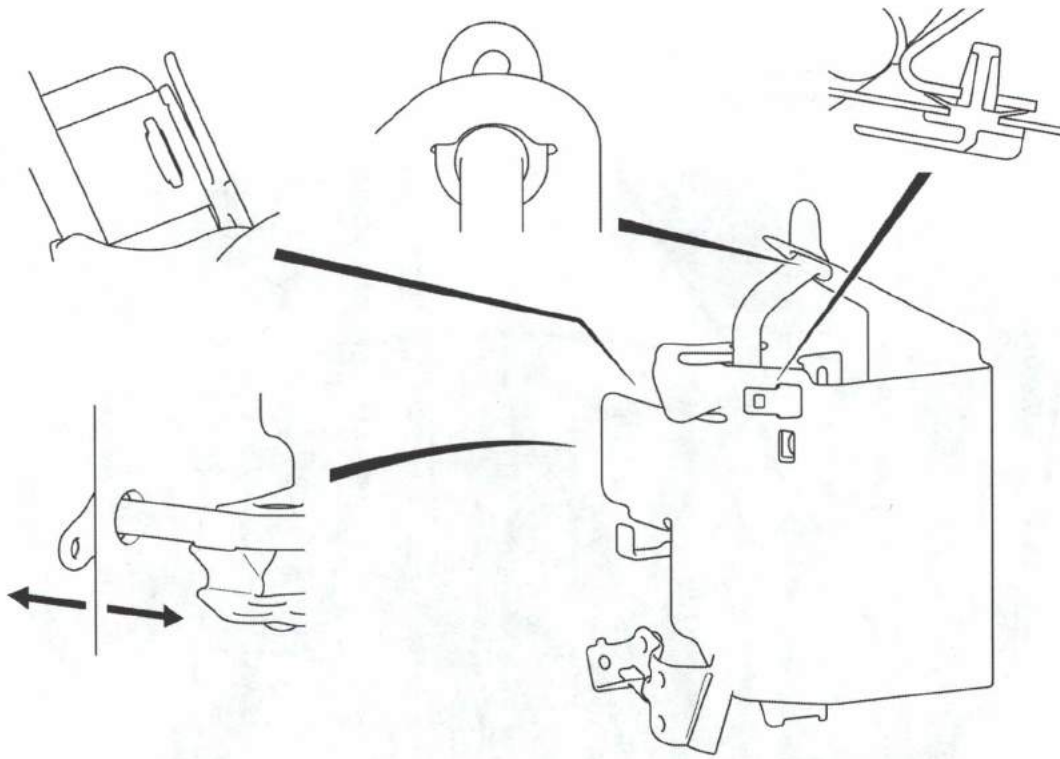

RESERVE TANK
OVERFLOW HOSE

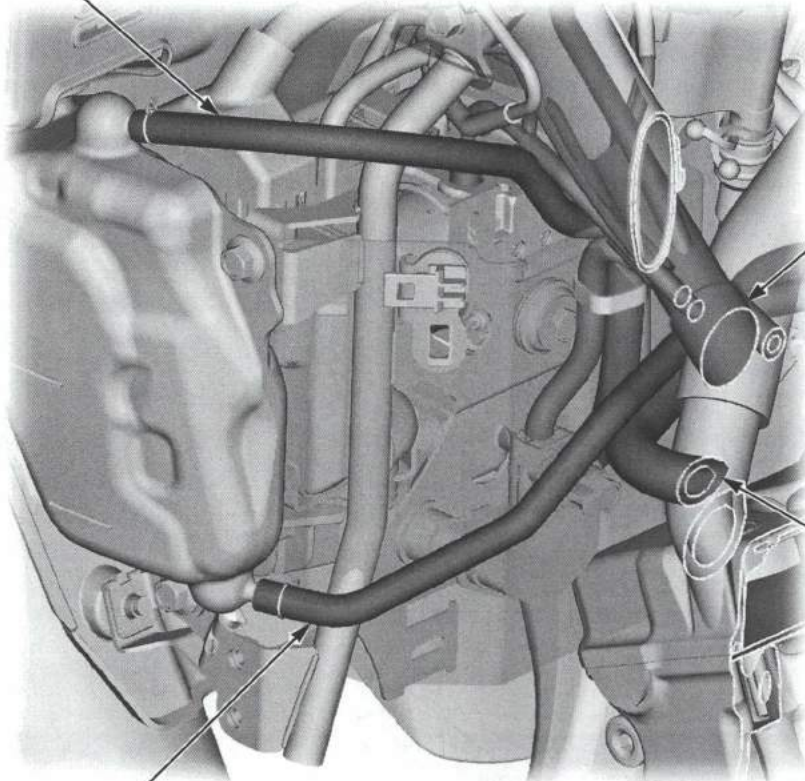

WIRE HARNESS

PAIR HOSE

RADIATOR
SIPHON HOSE



EVAP:

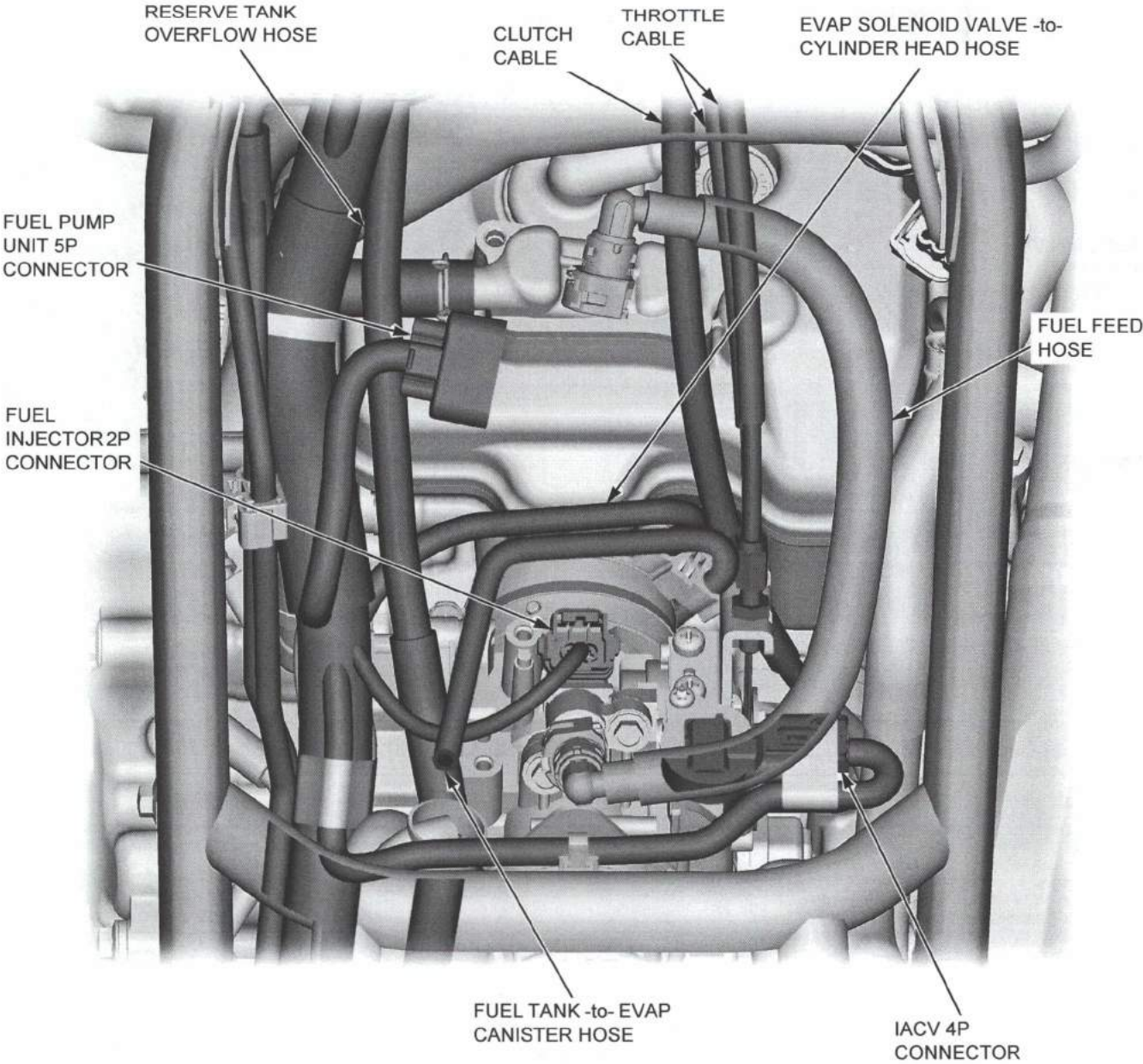



GENERAL INFORMATION

Except EVAP:

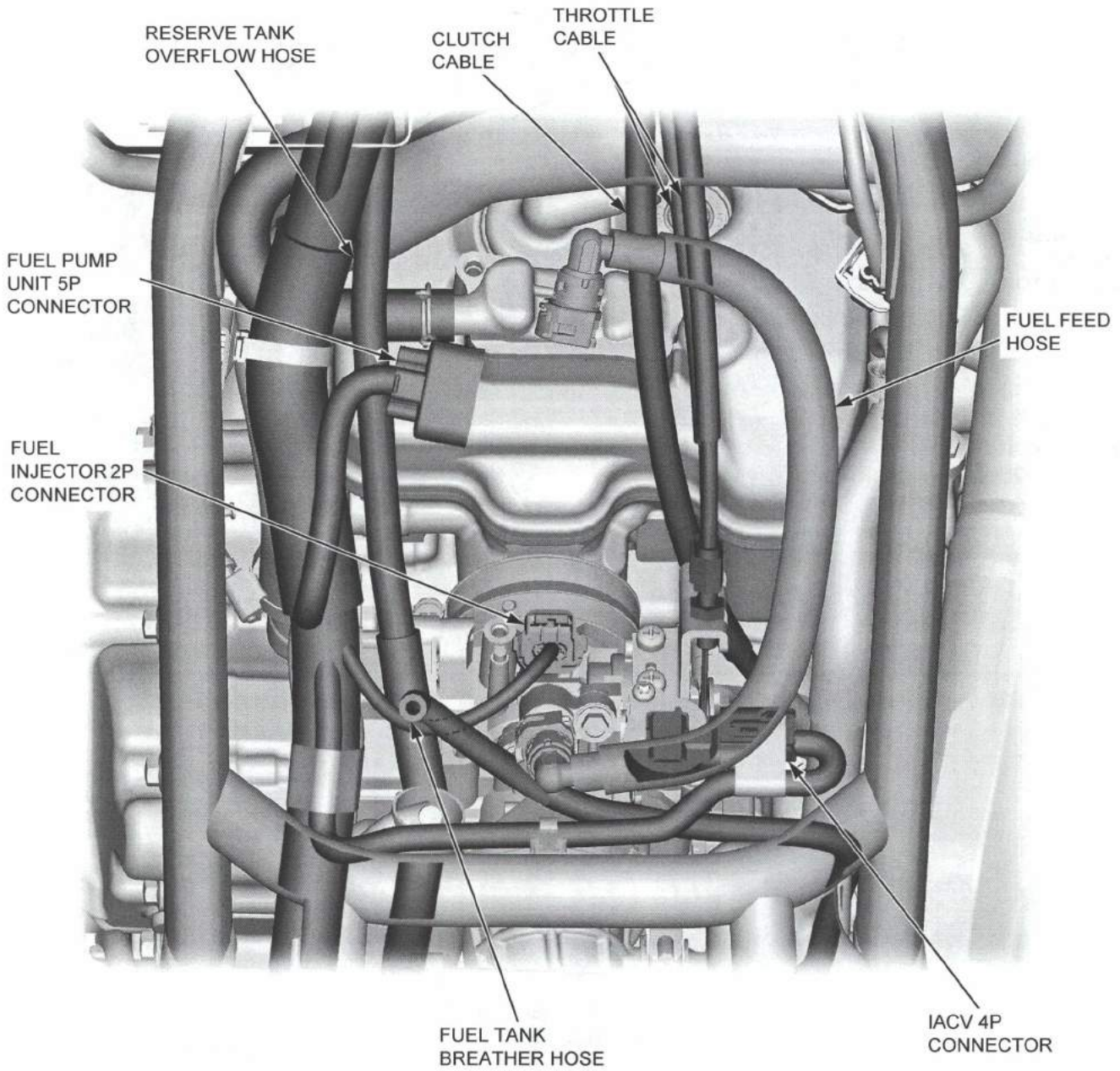



EVAP:

RESERVE TANK
OVERFLOW HOSE

WIRE HARNESS

EVAP CANISTER
BREATHER HOSE

EVAP CANISTER
BREATHER HOSE

EVAP CANISTER
BREATHER HOSE

EVAP PURGE CONTROL
SOLENOID VALVE 2P
CONNECTOR

GEAR POSITION SWITCH
8P CONNECTOR

SENSOR UNIT 5P
CONNECTOR

EVAP CANISTER
DRAIN HOSE

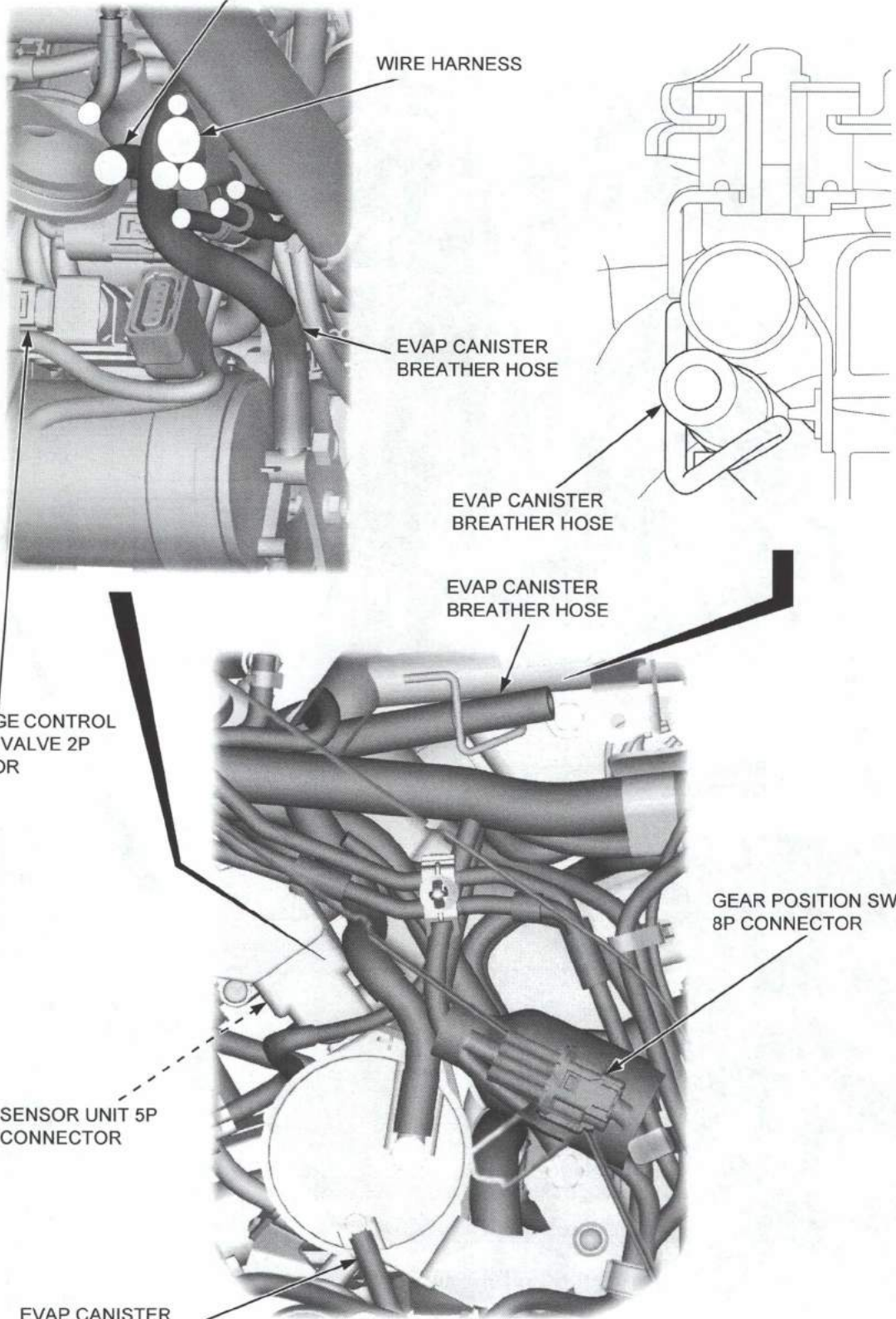



GENERAL INFORMATION

Except EVAP:

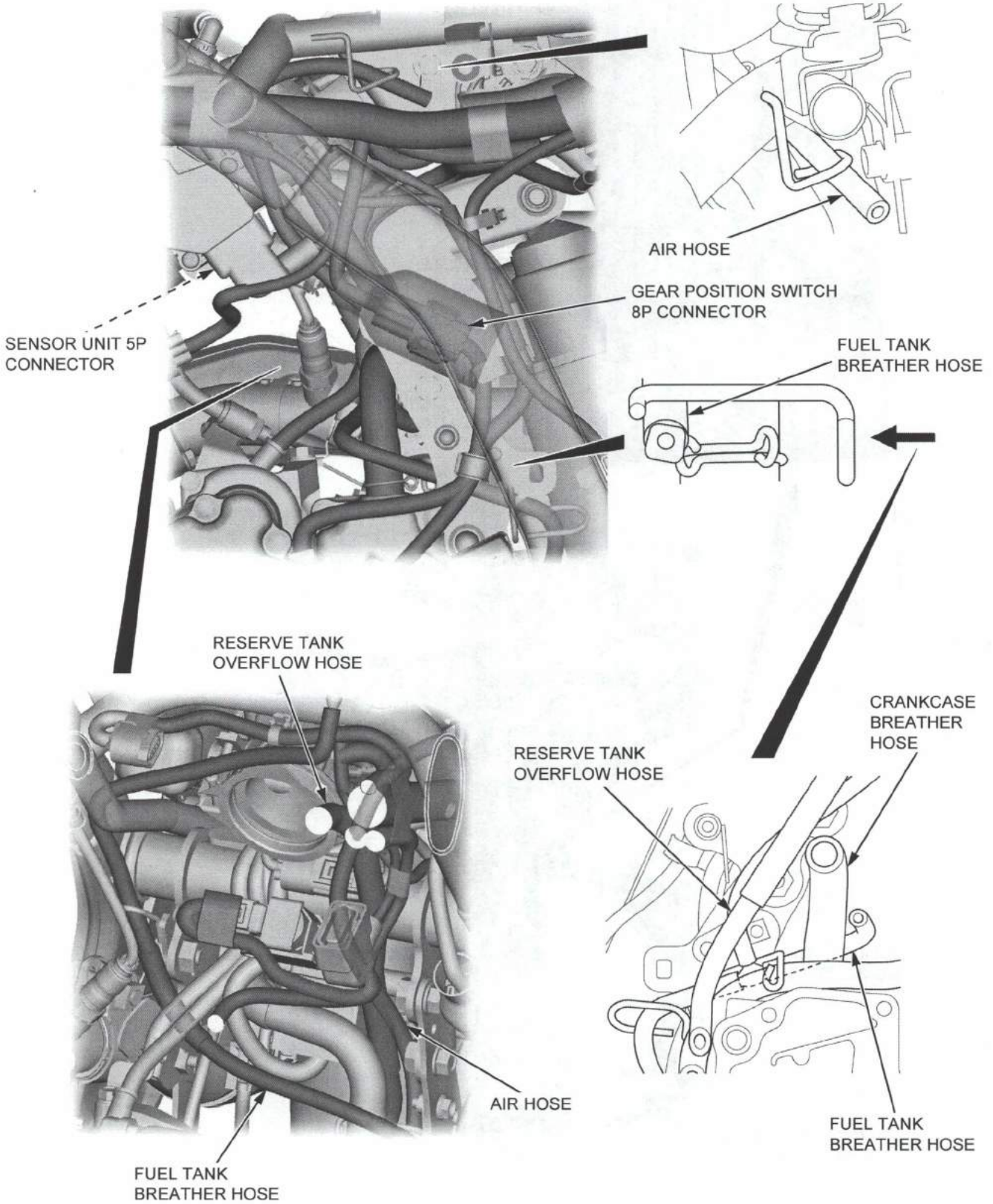



EVAP:

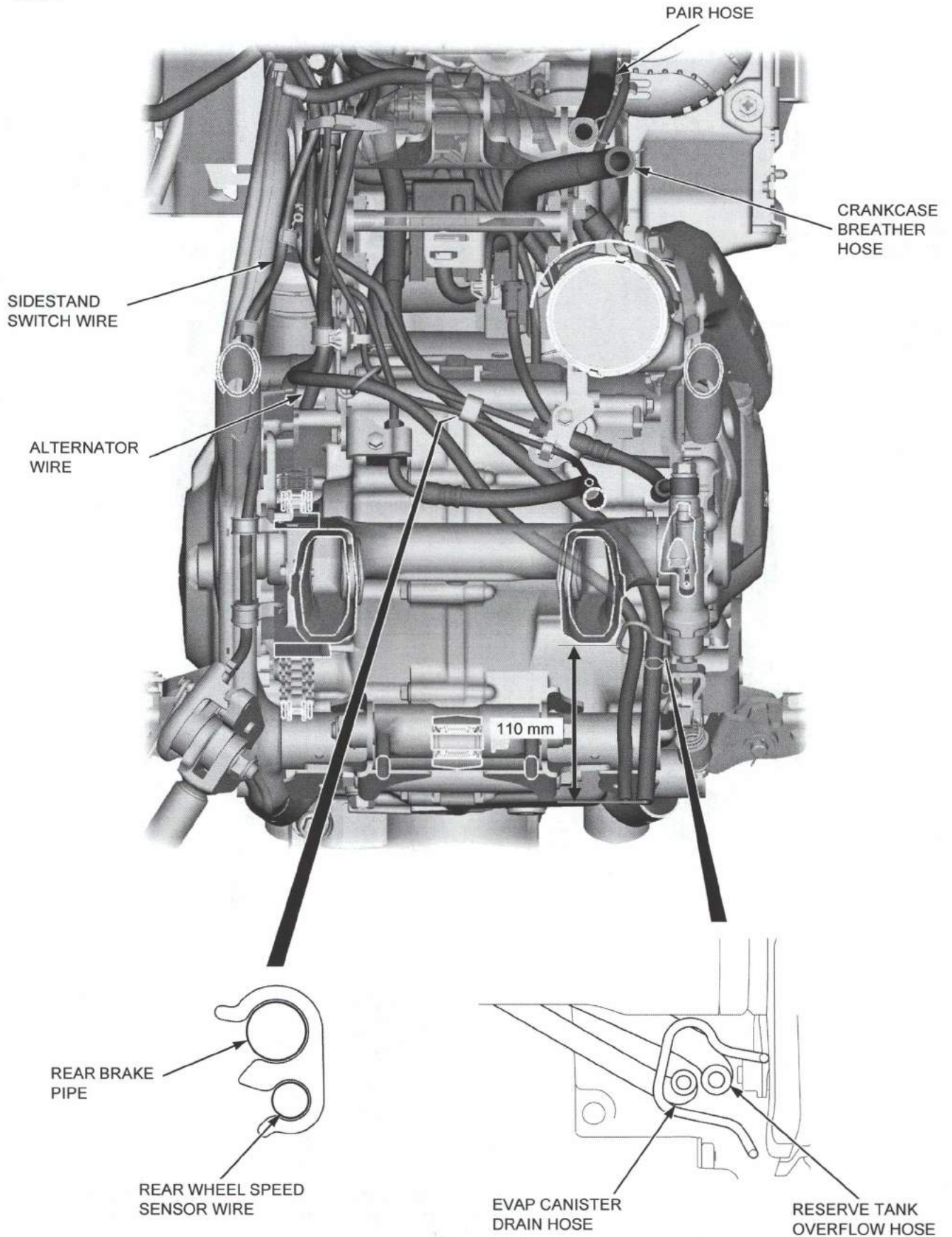



GENERAL INFORMATION

Except EVAP:

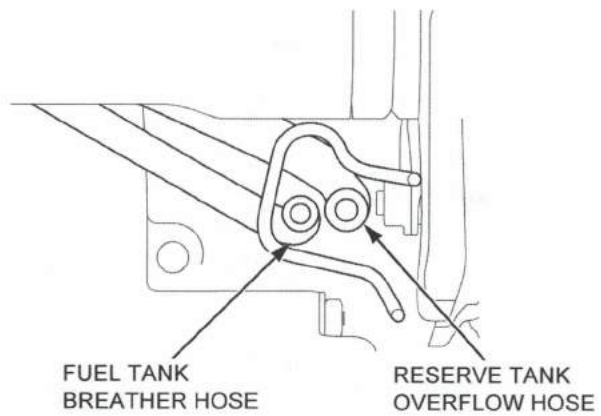
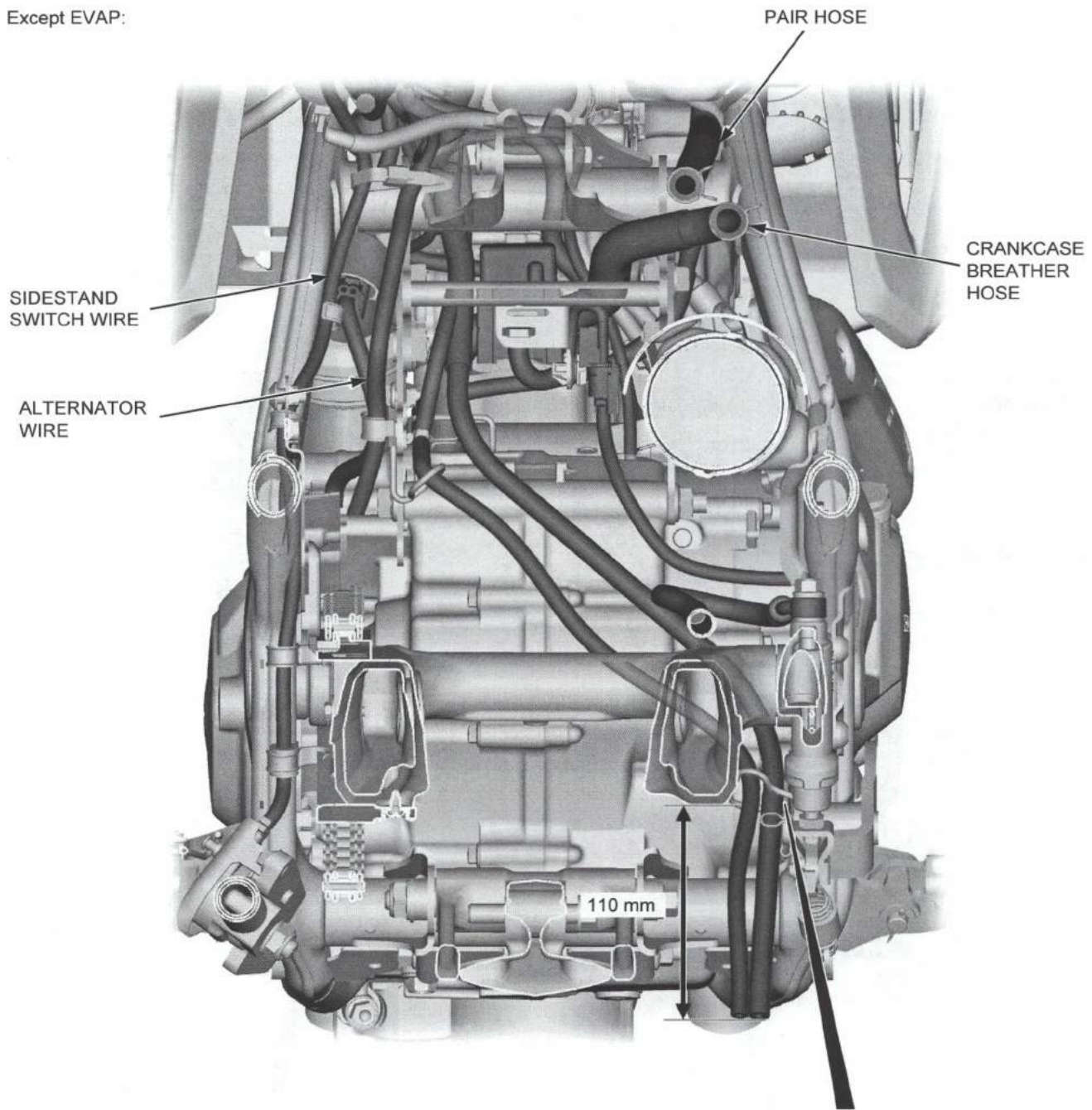

EMISSION CONTROL SYSTEMS

EXHAUST EMISSION REQUIREMENT

The U.S. Environmental Protection Agency (EPA), California Air Resources Board (CARB) and Environment and Climate Change Canada (ECCC) require manufacturers to certify that their motorcycles comply with applicable exhaust emissions standards during their useful life, when operated and maintained according to the instructions provided.

NOISE EMISSION REQUIREMENT

The EPA also requires that vehicles built after January 1, 1983 comply with applicable noise emission standards for one year or 3,730 miles (6,000 km) after the time of sale to the ultimate purchaser, when operated and maintained according to the instructions provided.

WARRANTY COMPLIANCE

Compliance with the terms of the Distributor's Limited Warranty for Honda Motorcycle Emission Control Systems is necessary in order to keep the emissions system warranty in effect.

SOURCE OF EMISSIONS

The combustion process produces carbon monoxide (CO), oxides of nitrogen (NOx) and hydrocarbons (HC).

The control of hydrocarbons and oxides of nitrogen is very important because, under certain conditions, they react to form photochemical smog when subject to sunlight. Carbon monoxide does not react in the same way, but it is toxic. Uncontrolled fuel evaporation also releases hydrocarbons to the atmosphere.

Honda Motor Co., Ltd. utilizes various system to reduce carbon monoxide, oxides of nitrogen and hydrocarbons.

CRANKCASE EMISSION CONTROL SYSTEM

The engine is equipped with a closed crankcase system to prevent discharging crankcase emissions into the atmosphere.

Blow-by gas is returned to the combustion chamber through the air cleaner and throttle body.

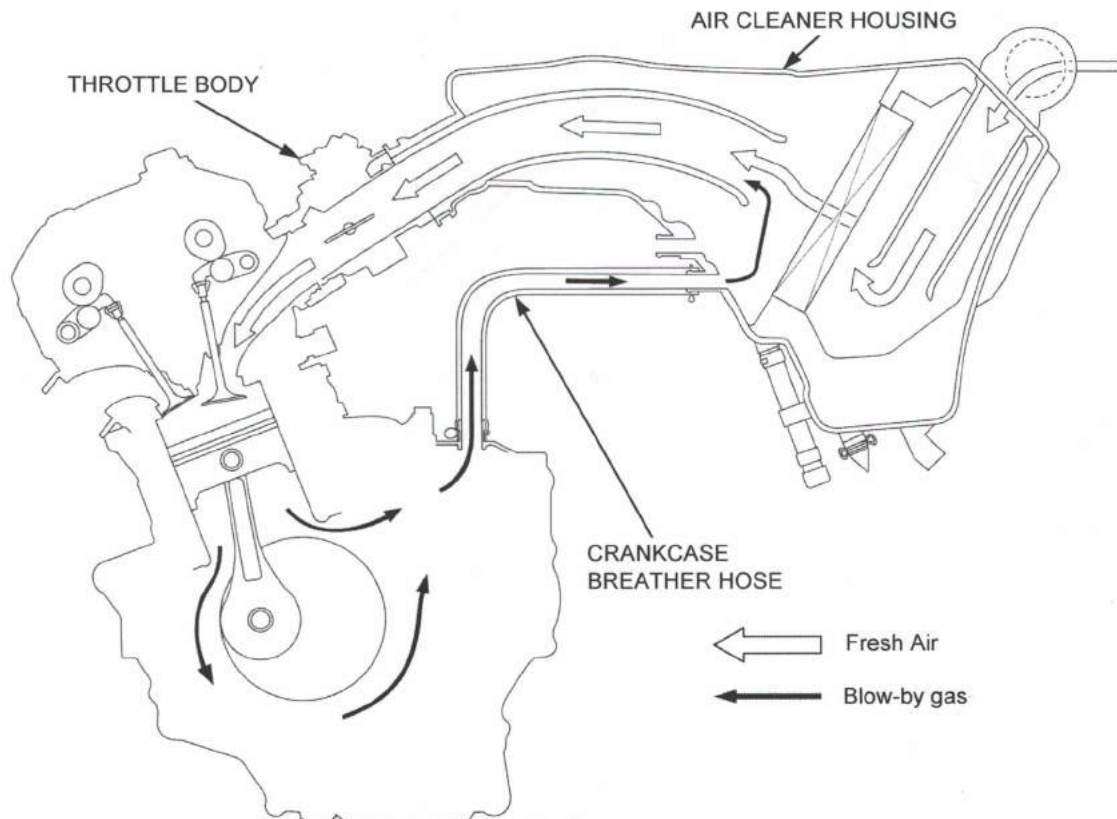



GENERAL INFORMATION

EXHAUST EMISSION CONTROL SYSTEM

The exhaust emission control system is composed of a three-way catalytic converter and PGM-FI system.

THREE-WAY CATALYTIC CONVERTER

This vehicle is equipped with a three-way catalytic converter. The three-way catalytic converter is in the exhaust system. Through chemical reactions, it convert HC, CO and NO_x in the engine's exhaust to carbon dioxide (CO₂), dinitrogen (N₂), and water vapor.

No adjustment to these systems should be made although periodic inspection of the components is recommended.

SECONDARY AIR SUPPLY SYSTEM

The pulse secondary air supply system introduces filtered air into the exhaust gases in the exhaust port. Fresh air is drawn into the exhaust port by the function of the PAIR control valve.

This charge of fresh air promotes burning of the unburned exhaust gases and changes a considerable amount of hydrocarbons and carbon monoxide into relatively harmless carbon dioxide and water vapor.

The reed valve prevents reverse air flow through the system. The PAIR control valve is operated by the solenoid valve. The solenoid valve is controlled by the PGM-FI unit, and the fresh air passage is opened/closed according to running condition (ECT/IAT/TP/MAP sensor and engine revolution).

No adjustments to the secondary air supply system should be made, although periodic inspection of the components is recommended.

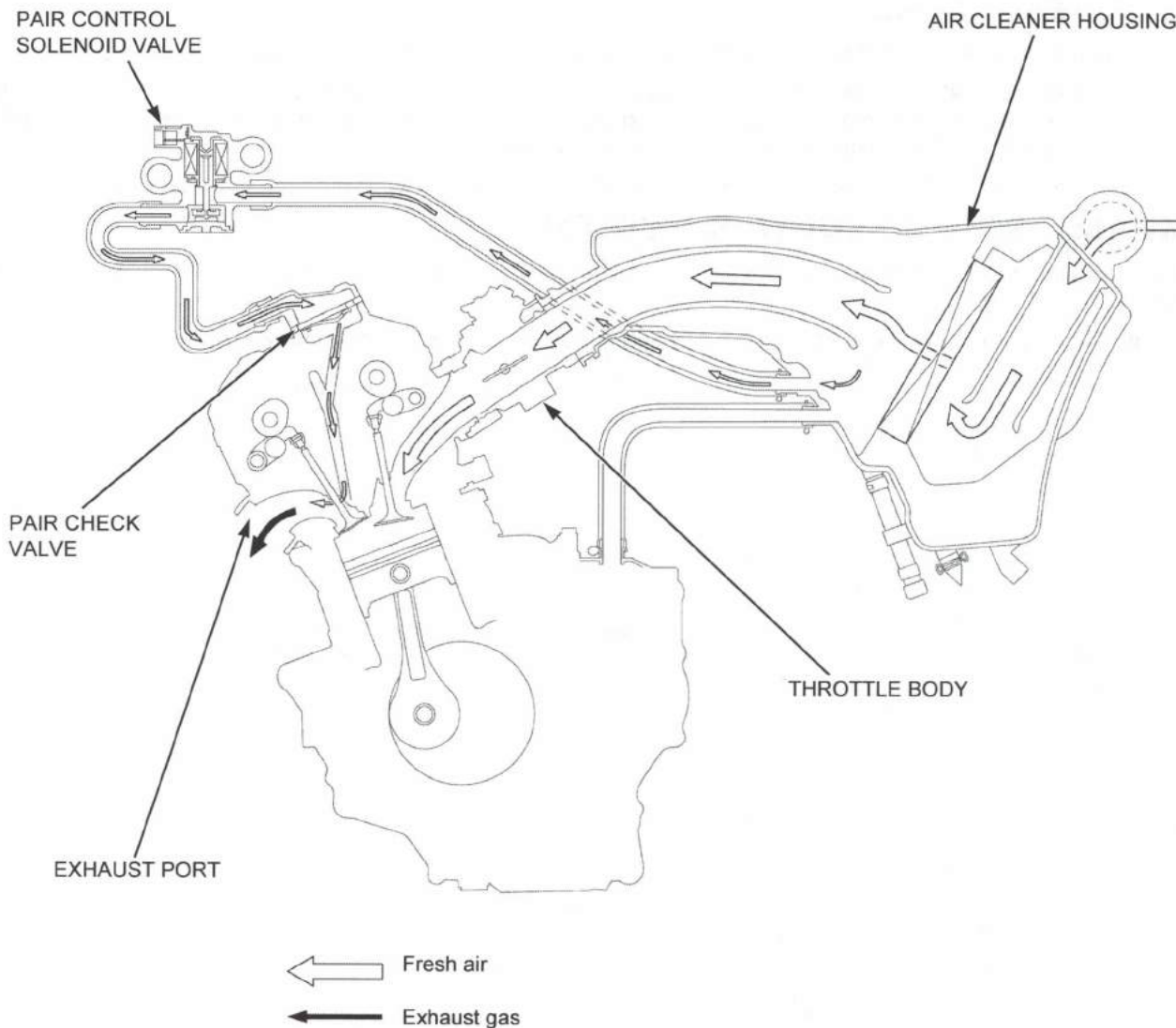

EVAPORATIVE EMISSION CONTROL SYSTEM

Fuel vapor from the fuel tank is routed into the EVAP canister where it is absorbed and stored while the engine is stopped. When the engine is running and the EVAP purge control solenoid valve is open, fuel vapor in the EVAP canister is drawn into the engine.

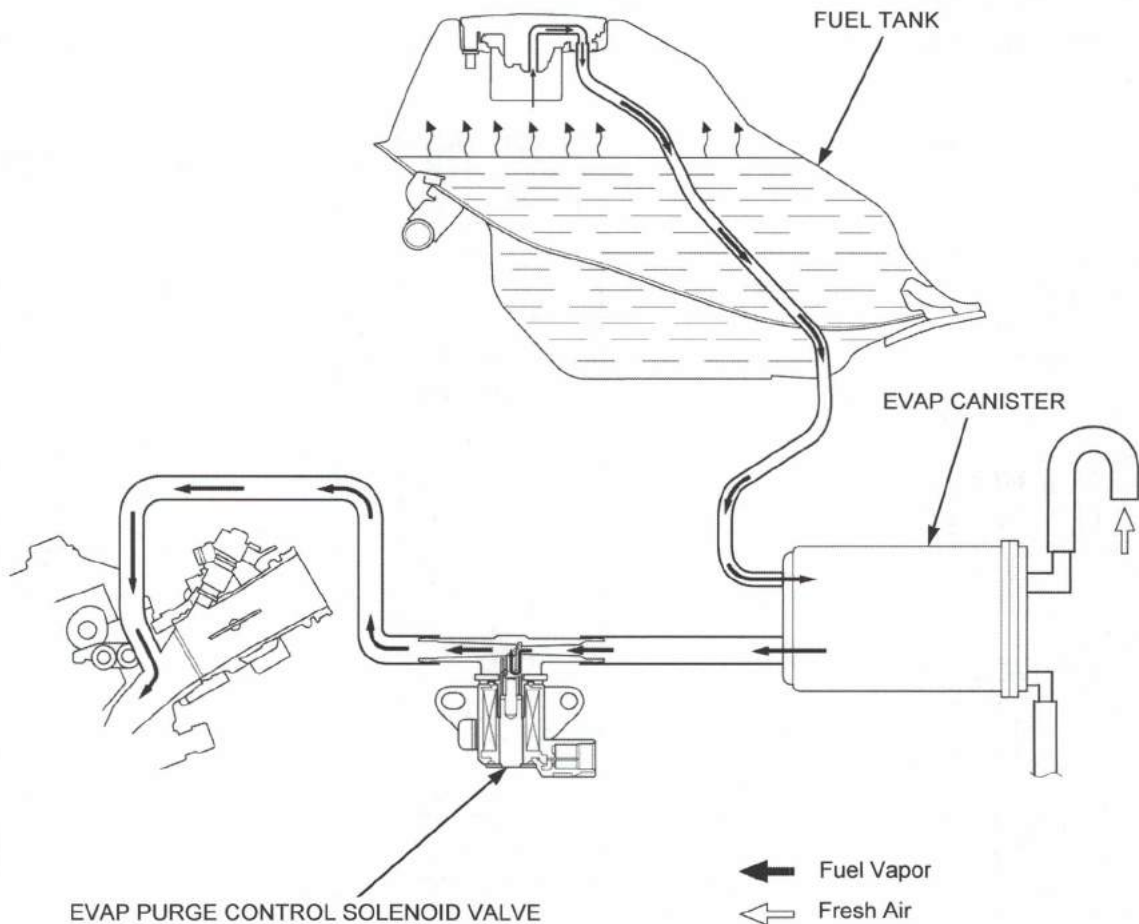

FUEL PERMEATION EMISSION CONTROL SYSTEM

This motorcycle complies with the Fuel Permeation Emission Control regulations of the U.S. Environmental Protection Agency (EPA), the California Air Resources Board (CARB), and Environment and Climate Change Canada (ECCC). The fuel tank, fuel hoses, and fuel vapor charge hoses used on this motorcycle incorporate fuel permeation control technologies. Tampering with the fuel tank, fuel hoses, or fuel vapor charge hoses to reduce or defeat the effectiveness of the fuel permeation technologies is prohibited by federal regulations.

NOISE EMISSION CONTROL SYSTEM

TAMPERING WITH THE NOISE CONTROL SYSTEM IS PROHIBITED: U.S. Federal law prohibits law may prohibit the following acts or the causing there of: (1) The removal or rendering inoperative by any person, other than for purposes of maintenance, repair or replacement, of any device or element of design incorporated into any vehicle for the purpose of noise control prior to its sale or delivery to the ultimate customer or while it is in use; (2) the use of the vehicle after such device or element of design has been removed or rendered inoperative by any person.

AMONG THOSE ACTS PRESUMED TO CONSTITUTE TAMPERING ARE THE ACTS LISTED BELOW:

1. Removal of, or puncturing of the muffler, baffles, header pipes or any other component which conducts exhaust gases.
2. Removal of, or puncturing of any part of the intake system.
3. Lack of proper maintenance.
4. Replacing any moving parts of the vehicle, or parts of the exhaust or intake system, with parts other than those specified by the manufacturer.



GENERAL INFORMATION

MAINTENANCE SCHEDULE

- Perform the Pre-ride inspection in the Owner's Manual at each scheduled maintenance period.
- I: Inspect and Clean, Adjust, Lubricate or Replace if necessary. C: Clean. R: Replace. A: Adjust. L: Lubricate.
- The following items require some mechanical knowledge. Certain items (particularly t marked * and **) may require more technical information and tools. Consult a dealer.



- Refer to "Basic" Service Manual for each maintenance instruction except the instructions described in this manual.

ITEMS	FREQUENCY	NOTE	FREQUENCY (NOTE 1)								REGULAR REPLACE	REFER TO PAGE			
			X1,000 mi	0.6	4	8	12	16	20	24					
			X1,000 km	1.0	6.4	12.8	19.2	25.6	32.0	38.4					
EMISSION RELATED ITEMS	* FUEL LINE					I			I						→2-2
	* THROTTLE OPERATION					I			I						
	AIR CLEANER	NOTE2						R					R		→2-7
	CRANKCASE BREATHER	NOTE3				C	C	C	C	C	C				
	SPARK PLUG														EVERY 16000 mi (25600 km) I, EVERY 32000 mi (51200 km) R →4-28
	* VALVE CLEARANCE									I					→2-22
	ENGINE OIL					R		R		R			R	1 year	→2-15
	ENGINE OIL FILTER					R				R					→2-15
	* ENGINE IDLE SPEED						I			I					
	RADIATOR COOLANT	NOTE7					I			I			I	3 years	→2-17
	* COOLING SYSTEM						I			I					
	* SECONDARY AIR SUPPLY SYSTEM									I					
* EVAPORATIVE EMISSION CONTROL SYSTEM	NOTE4								I						
NON-EMISSION RELATED ITEMS	DRIVE CHAIN	NOTE5													Every 600 mi (1000 km) I, L
	DRIVE CHAIN SLIDER					I	I	I	I	I	I				
	BRAKE FLUID	NOTE7				I	I	I	I	I	I		2 years	→3-37	
	BRAKE PADS WEAR					I	I	I	I	I	I				
	BRAKE SYSTEM					I			I						
	BRAKE LIGHT SWITCH					I			I						
	HEADLIGHT AIM					I			I					→4-57	
	CLUTCH SYSTEM					I	I	I	I	I	I				
	SIDESTAND					I			I						
	* SUSPENSION					I			I						
	* SPARK ARRESTER	NOTE6				C	C	C	C	C	C	C			
	* NUTS, BOLTS, FASTENERS	NOTE5					I			I					
** WHEELS/TIRES	NOTE5				I	I	I	I	I	I					
** STEERING HEAD BEARINGS					I			I							

- * Should be serviced by a dealer, unless the owner has proper tools and service data and is mechanically qualified.
- ** In the interest of safety, we recommend these items be serviced only by a dealer.

NOTES:

1. At higher odometer readings, repeat at the frequency interval established here.
2. Service more frequently when riding in unusually wet or dusty areas.
3. Service more frequently when riding in rain or at full throttle.
4. 50 STATE (meets California)
5. Service more frequently when riding OFF-ROAD.
6. USA only.
7. Replacement requires mechanical skill.

2. FUEL & ENGINE

FUEL LINE	2-2	CYLINDER HEAD	2-22
FUEL PUMP UNIT	2-4	CYLINDER/PISTON	2-29
FUEL TANK	2-6	CLUTCH/GEARSHIFT LINKAGE	2-30
AIR CLEANER	2-7	ALTERNATOR/STARTER CLUTCH	2-33
THROTTLE BODY	2-8	CRANKCASE/CRANKSHAFT/ BALANCER	2-35
SECONDARY AIR SUPPLY SYSTEM	2-12	TRANSMISSION	2-39
LUBRICATION SYSTEM	2-14	ENGINE UNIT	2-40
COOLING SYSTEM	2-17		





FUEL LINE

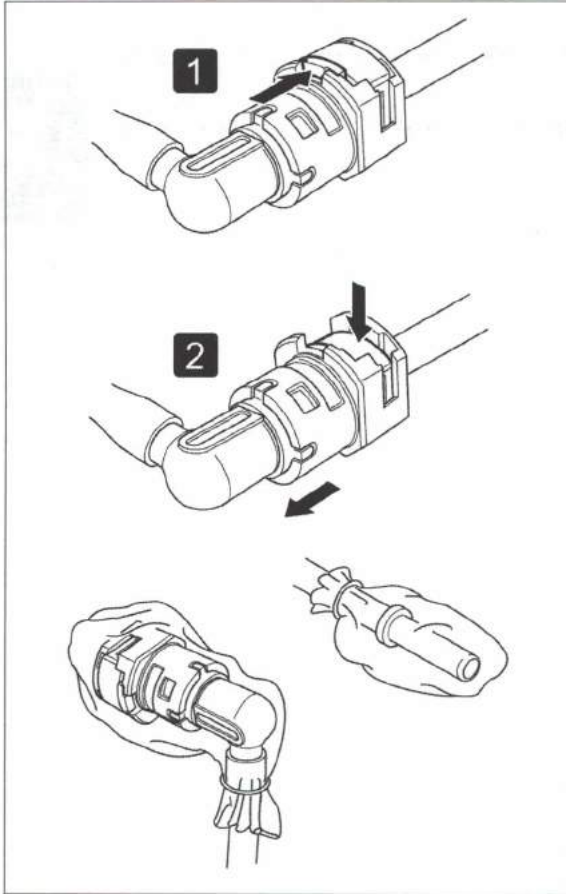
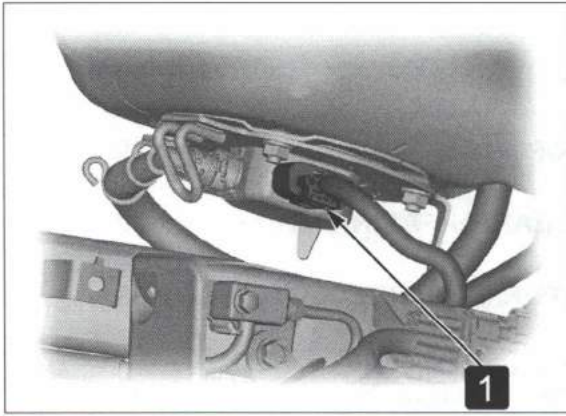

• This vehicle uses resin for the parts of materials in the fuel hose. Do not bend or twist the fuel hose.

• Fuel tank lifting →2-6

• **1** Fuel pump 5P connector

• Let the engine idle until it stops.

• Battery negative (-) cable →4-51



• Do not use tools in removal. If the connector does not move, alternately pull and push the connector until it comes off easily.

• Check the fuel quick connect fitting for dirt, and clean if necessary.

• Place a shop towel over the quick connect fitting.

• **1** Push the retainer tab forward.

• **2** Press down the retainer and disconnect the connector from the fuel joint.

• Check the retainer condition and replace the fuel hose if necessary.

• To prevent damage and keep foreign matter out, cover the disconnected connector and pipe end with a plastic bag.

• Press the connector onto the fuel joint until the retainer locks with a "CLICK". If it is hard to connect, put a small amount of engine oil on the pipe end.

• Make sure the connection is secure; check visually and by pulling the connector.

• After installing the removed parts, turn the ignition switch ON. (Do not start the engine.)

The fuel pump will run for about 2 seconds, and fuel pressure will rise. Repeat 2 or 3 times, and check that there is no leakage in the fuel supply system.





FUEL SUPPLY TEST



- If the fuel in tank is sufficient but such symptom as poor engine performance, lack of fuel, or engine start failure exist, perform the following.
- Perform the fuel pressure test. →2-3
- If the fuel pressure is within specification, perform the fuel flow inspection. →2-3
- Perform the fuel flow inspection in the specified fuel quantity. →2-3

FUEL PRESSURE TEST

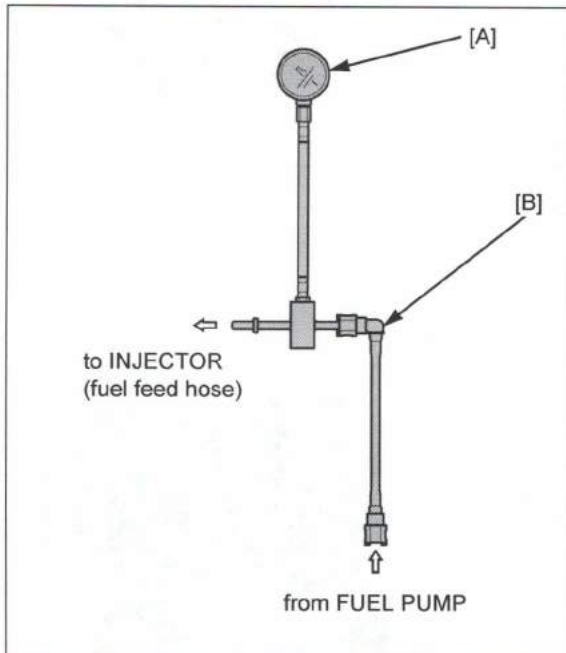

- Quick connect fitting (fuel pump side) →2-2

- Attach the fuel pressure gauge and attachment.

[A] Fuel pressure gauge: 07406-0040004

[B] Fuel pressure gauge attachment: 070MJ-K260100



- Temporarily connect the negative cable to the battery and fuel pump 5P connector.

Start the engine and let it idle, and read the fuel pressure.

Standard: 288 – 300 kPa



- If the fuel pressure is higher than specified, replace the fuel pump unit. →2-4

- If the fuel pressure is lower than specified, inspect the following.

– Fuel line leaking

– Any erratic swing or vibration of the gauge needle in the pressure gauge reading.

- If the needle is swing or vibration, replace the fuel filter. →2-5

- If the needle is stable, replace the fuel pump unit. →2-4

FUEL FLOW INSPECTION

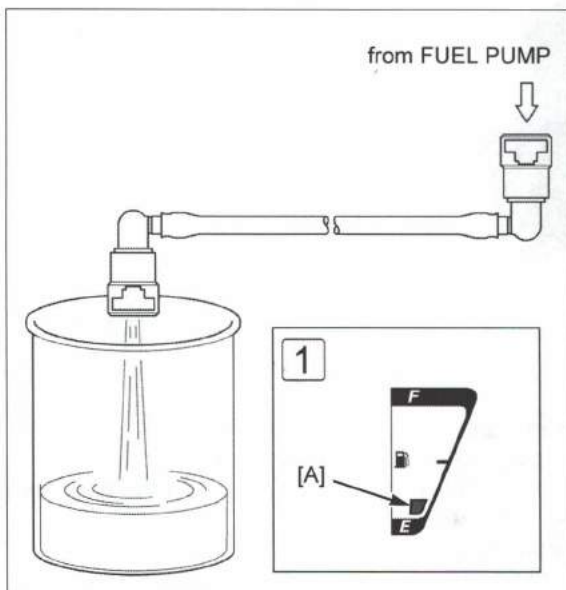

- Quick connect fitting (injector side) →2-2

- Place the end of the hose into an approved gasoline container. Wipe off spilled out gasoline.



- The fuel pump operates for 2 seconds. Repeat 5 times to meet the total measuring time.

Standard: 55.6 cm³ minimum/10 seconds



- If fuel flow is less than specified, inspect the following:

– Clogged fuel hose

– Fuel pump unit

- 1 Place the vehicle on the level ground with its sidestand. Adjust the fuel in the tank so that the fuel gauge segment is positioned the specified range [A], and inspect the fuel flow.

– If the fuel flow is above specification, check for other malfunctioning parts.

– If the fuel flow is under specification, replace the fuel filter. →2-5



FUEL PUMP UNIT

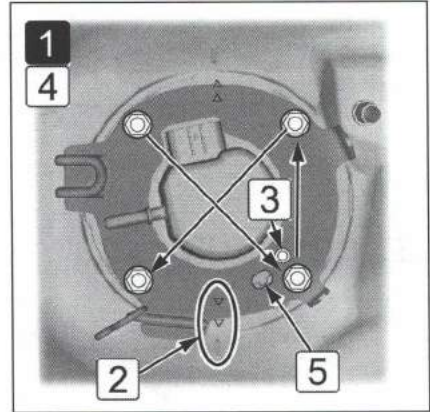
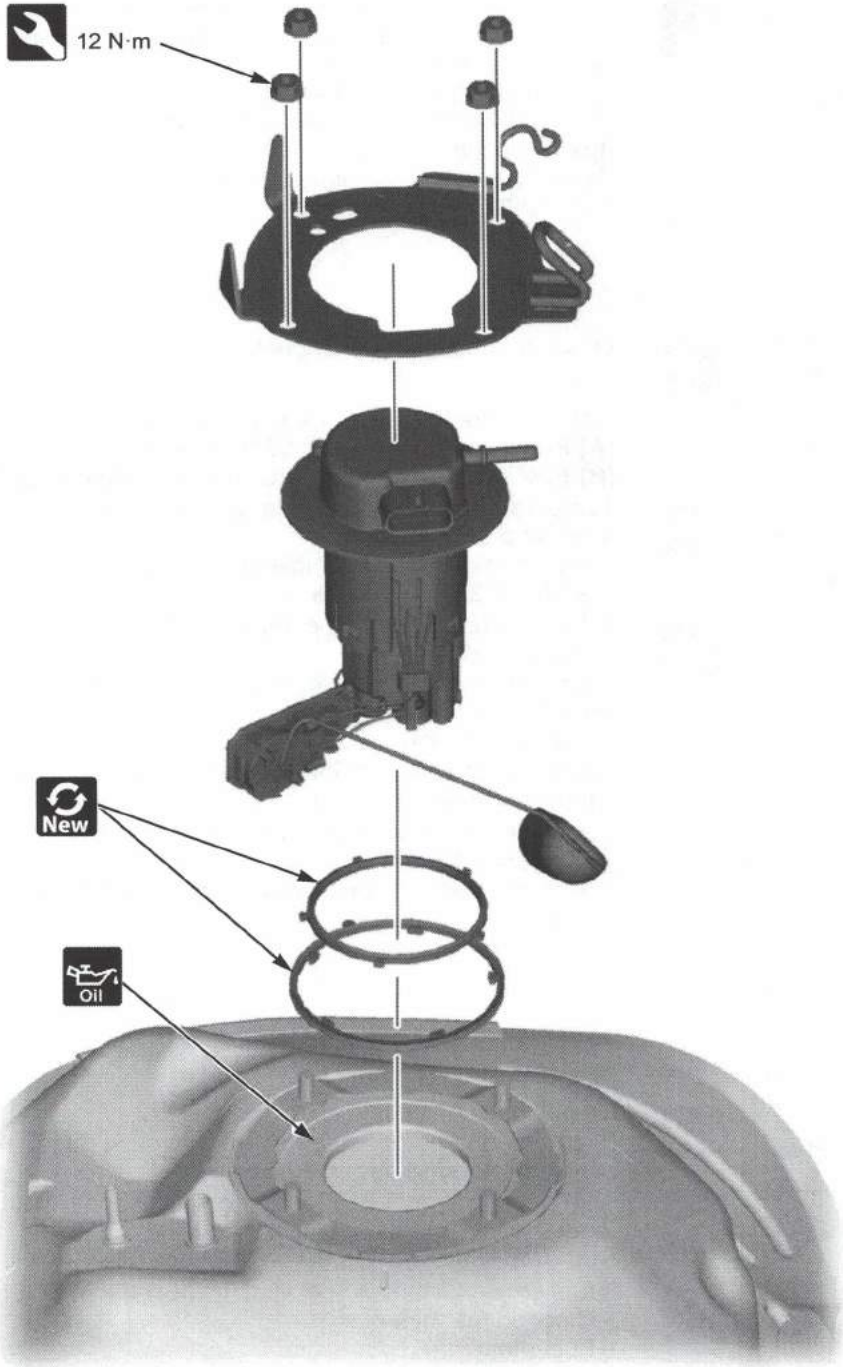

- Quick connect fitting (fuel pump side) →2-2
- Fuel tank →2-6



- **1** Loosen the nuts in a crisscross pattern in several steps.
- Carefully remove the fuel pump unit from the fuel tank to prevent damaging the fuel level sensor.
- **1** Install a new outer packing onto the fuel pump unit groove by aligning its tab with the boss.
- **2** Install the fuel pump into the fuel tank by aligning the triangle marks of the setting plate and the fuel tank.
- **3** Set the setting plate onto the fuel pump by aligning its hole with the boss.
- **4** Tighten the fuel pump setting plate nuts in the specified sequence as shown.
- **5** Make sure that the outer packing tab can be seen in the setting plate hole.



- Fuel pump malfunction and inspection



FUEL FILTER

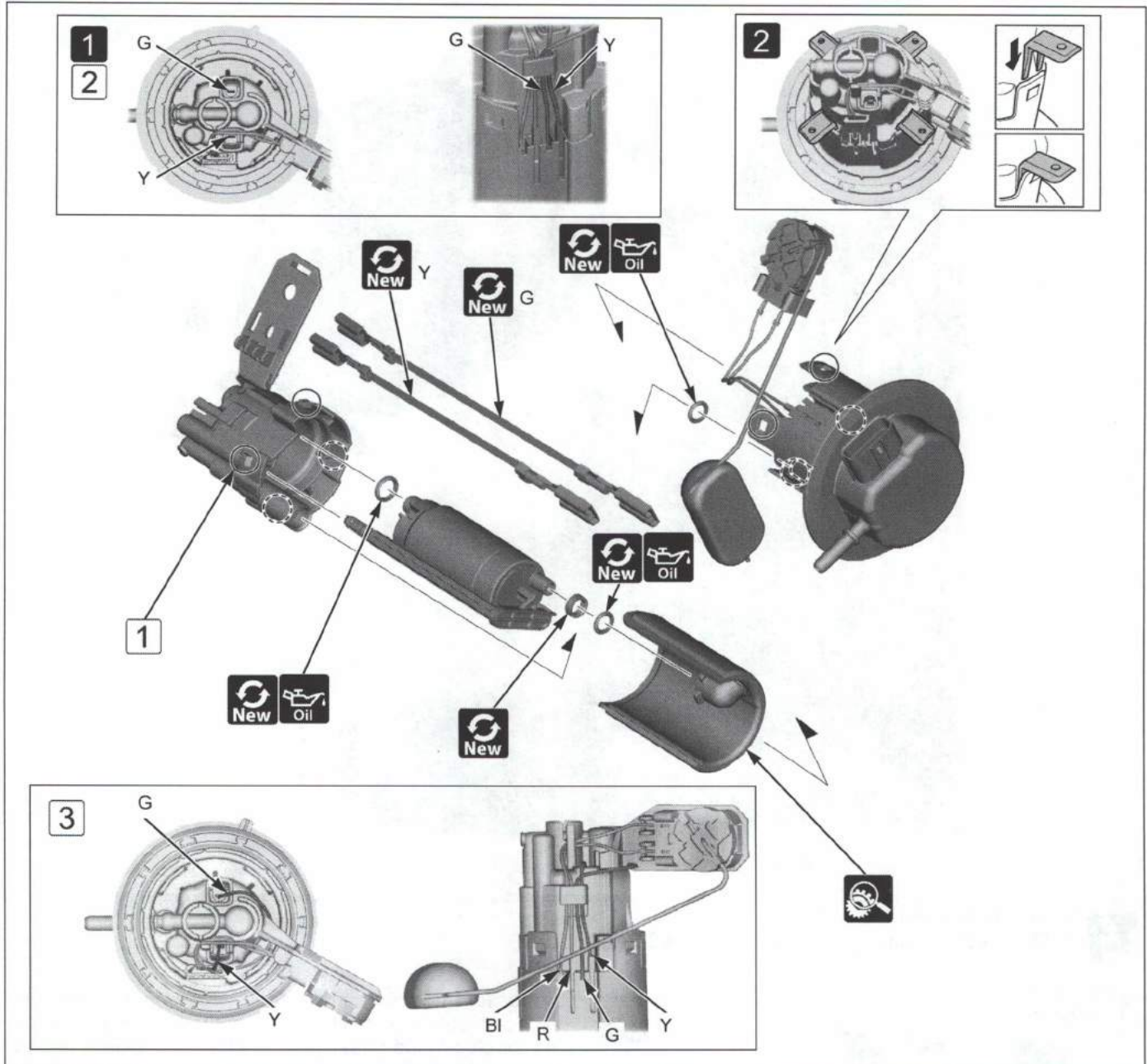

- Fuel clog or excessively damaged
- If the fuel filter is clogged, replace it with a new one.



- To prevent dirt and debris from entering the fuel pump unit, always clean it before disassembly.
- Clean the fuel pump unit and fuel pump filter with clean gasoline. Never use commercially available carburetor cleaners.
- 1 Fuel pump motor wires (Y and G wire)
- 2 Release the hooks from the stoppers by slightly spreading the hooks.

Fuel pump case remover: 070MF-KVS0300



- Before installing the fuel pump filter, check the fuel pump unit for dirt. If necessary, clean the fuel pump unit with compressed air. Do not blow into the fuel pump unit.
- If the R or BI wire connector is disconnected, replace the fuel level sensor with a new one.
- 1 Make sure the "CLICK" and install the four tabs securely when the fuel pump unit is assembled.
- 2 Connect the fuel pump motor wires to the specified angle.
- 3 Route the fuel pump motor wires and fuel level sensor wires to the guide and terminals properly.



FUEL TANK

Rally type shown:

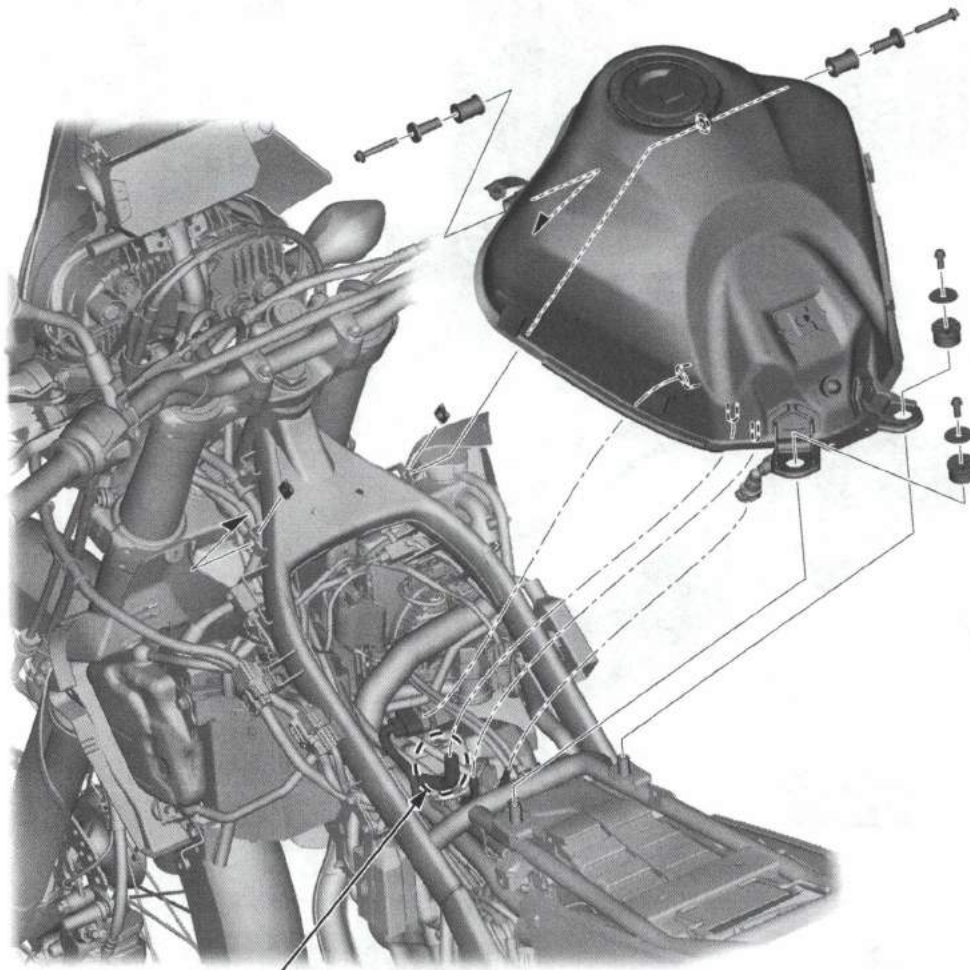

Rally type only



- Fuel tank shroud →3-13
- Quick connect fitting (fuel pump side) →2-2

Rally type only:

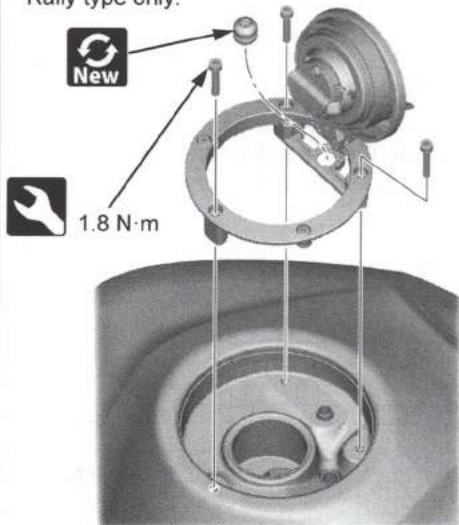

- A pressure release can be heard when opening the fuel filler cap, but this is not blockage of the passage. If checking for clog in the passage of the fuel tank side is necessary, apply air pressure to the breather hose end with the fuel filler cap opened.







- If remove the fuel filler cap, replace the breather seal with a new one.

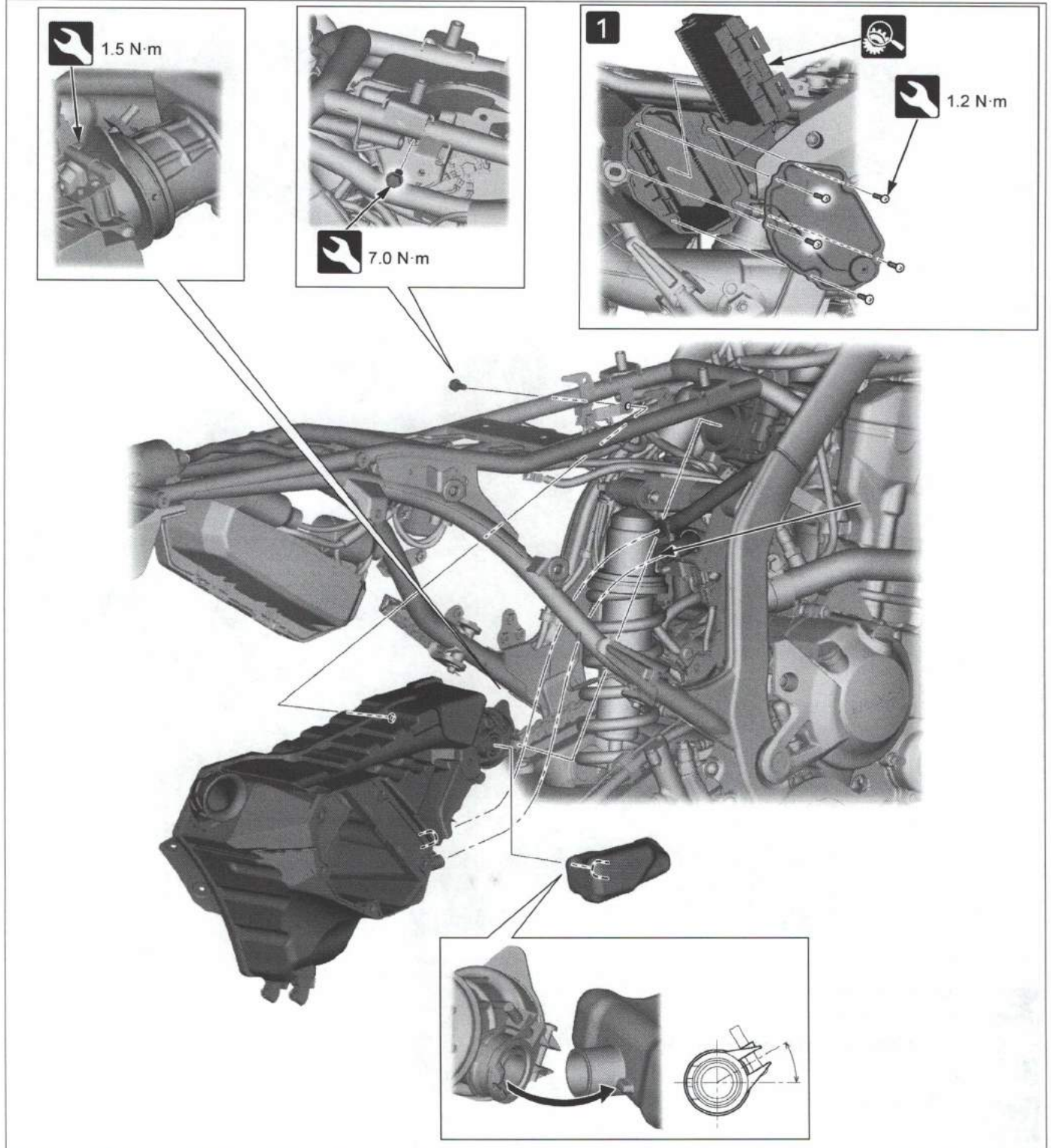

AIR CLEANER



-  • **1** Discard the air cleaner element in accordance with the maintenance schedule. → 1-68
-  • Replace the element any time it is excessively dirty or damaged.
-  • Fuel tank → 2-6
-  • Rear fender B → 3-17



THROTTLE BODY

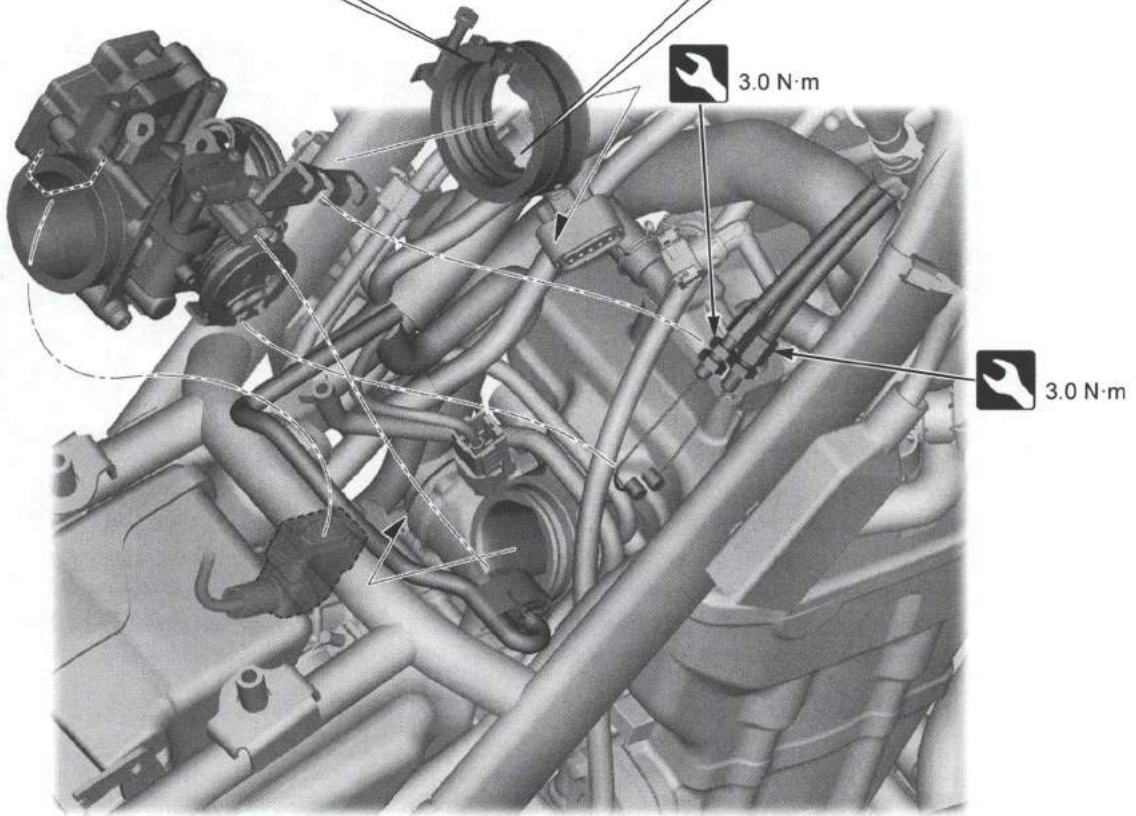
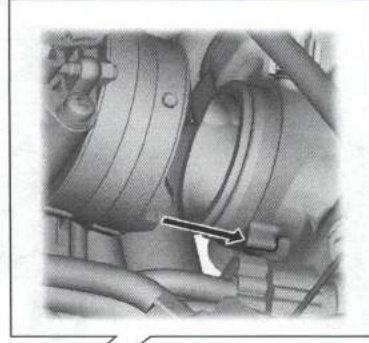
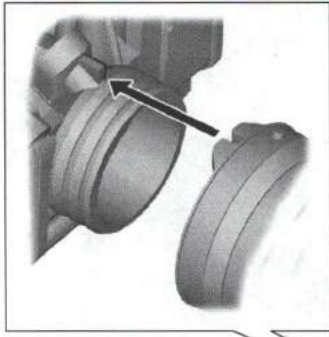

- Air cleaner →2-7
- Injector →2-11



- TP sensor reset procedure →2-10



Basic

- Throttle body cleaning and inspection

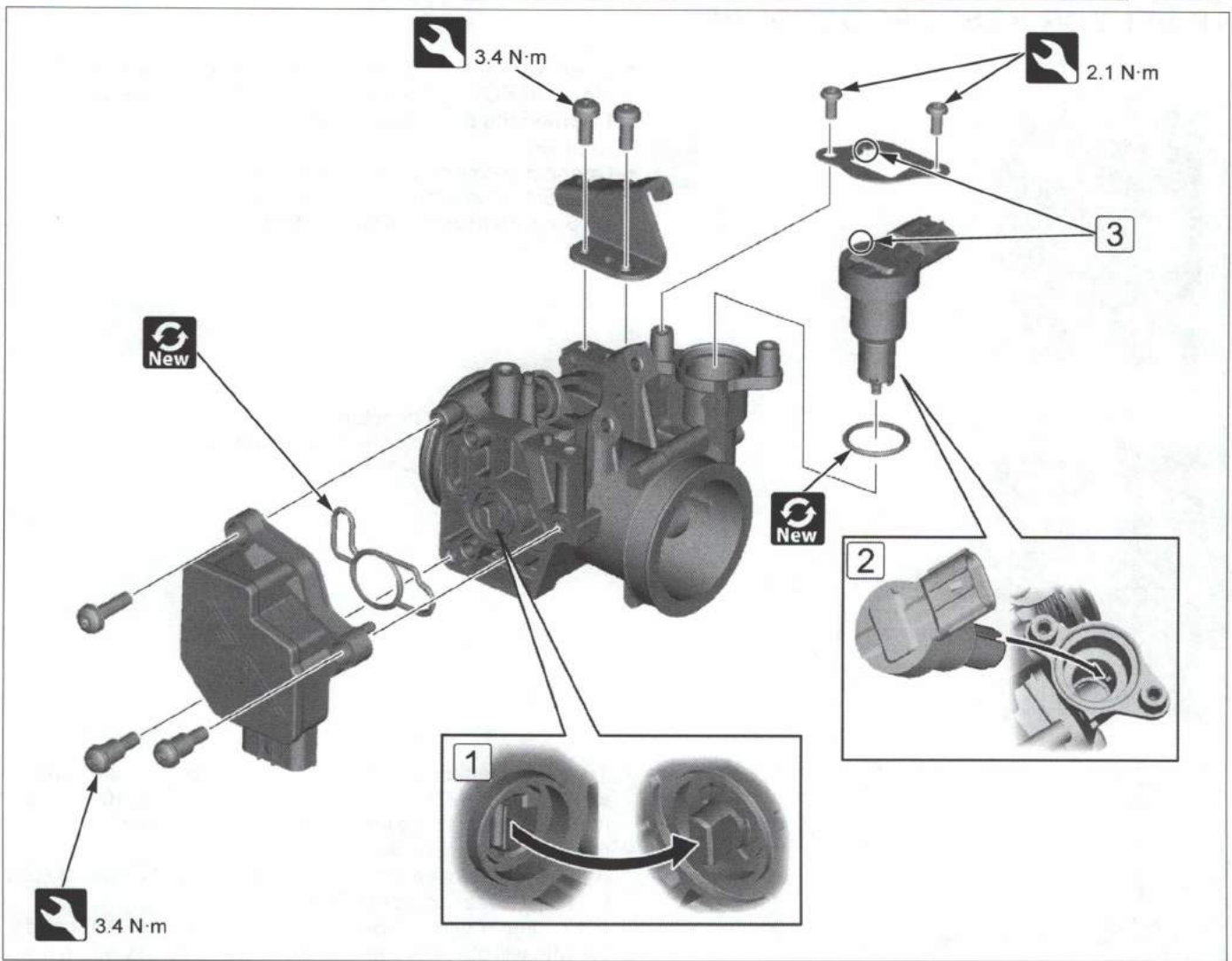

- The throttle body is factory pre-set. Do not disassemble in a way other than shown in this manual.
- Do not loosen or tighten the white painted fasteners. Loosening or tightening it can cause throttle body malfunction.
- Do not hold the throttle drum when installing the sensor unit.

Sensor unit



- Throttle body →2-8



- ① Install the sensor unit to the throttle body by aligning the clip of the sensor unit and boss of the throttle valve.
- Perform the TP sensor reset procedure. →2-10

IACV



- Fuel tank →2-6



- ② Install the IACV by aligning its slide valve slot with the pin in the throttle body.
- ③ Install the set plate by aligning its slot with the IACV tab.



TP SENSOR RESET PROCEDURE

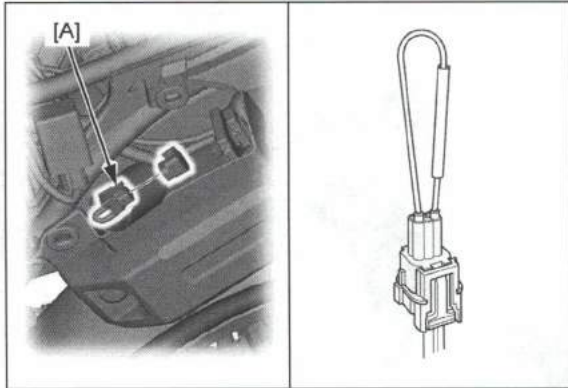

- Make sure that DTC is not stored in ECM. If the DTC is stored in ECM, TP sensor reset mode won't start by following the procedure below.

- Seat →3-5
- Connector cover from the DLC [A].
- Connect the special tool to the DLC.
SCS connector: 070MZ-0010300

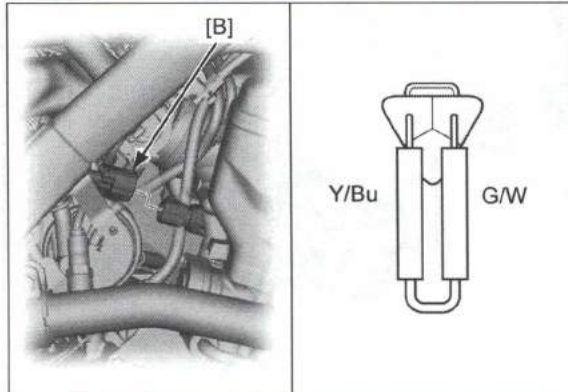

- ECT sensor 3P connector [B].
- Short the ECT sensor terminals with jumper wire.
Connection: G/W – Y/Bu

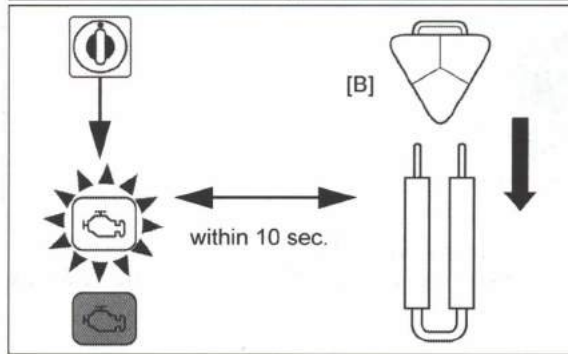

- Turn the ignition switch ON then disconnect the jumper wire from the ECT sensor 3P connector within 10 seconds while the MIL is blinking (reset receiving pattern).
- Check if the MIL blinks.
After disconnection of the jumper wire, the MIL should start blinking. (reset completed pattern)
If the jumper wire is connected for more than 10 seconds, the MIL will stay ON (unsuccessful pattern). Try again from the first step.
- Check the engine idle speed.

Reset procedure and MIL blinking pattern

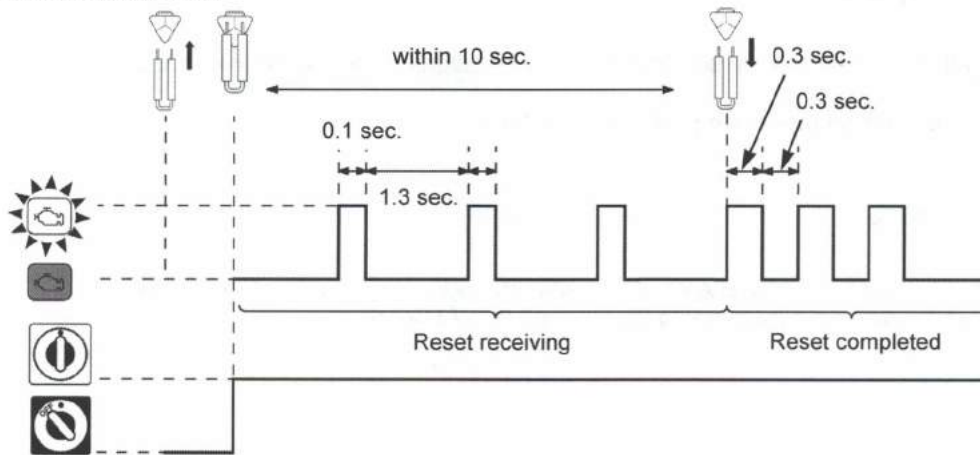



INJECTOR

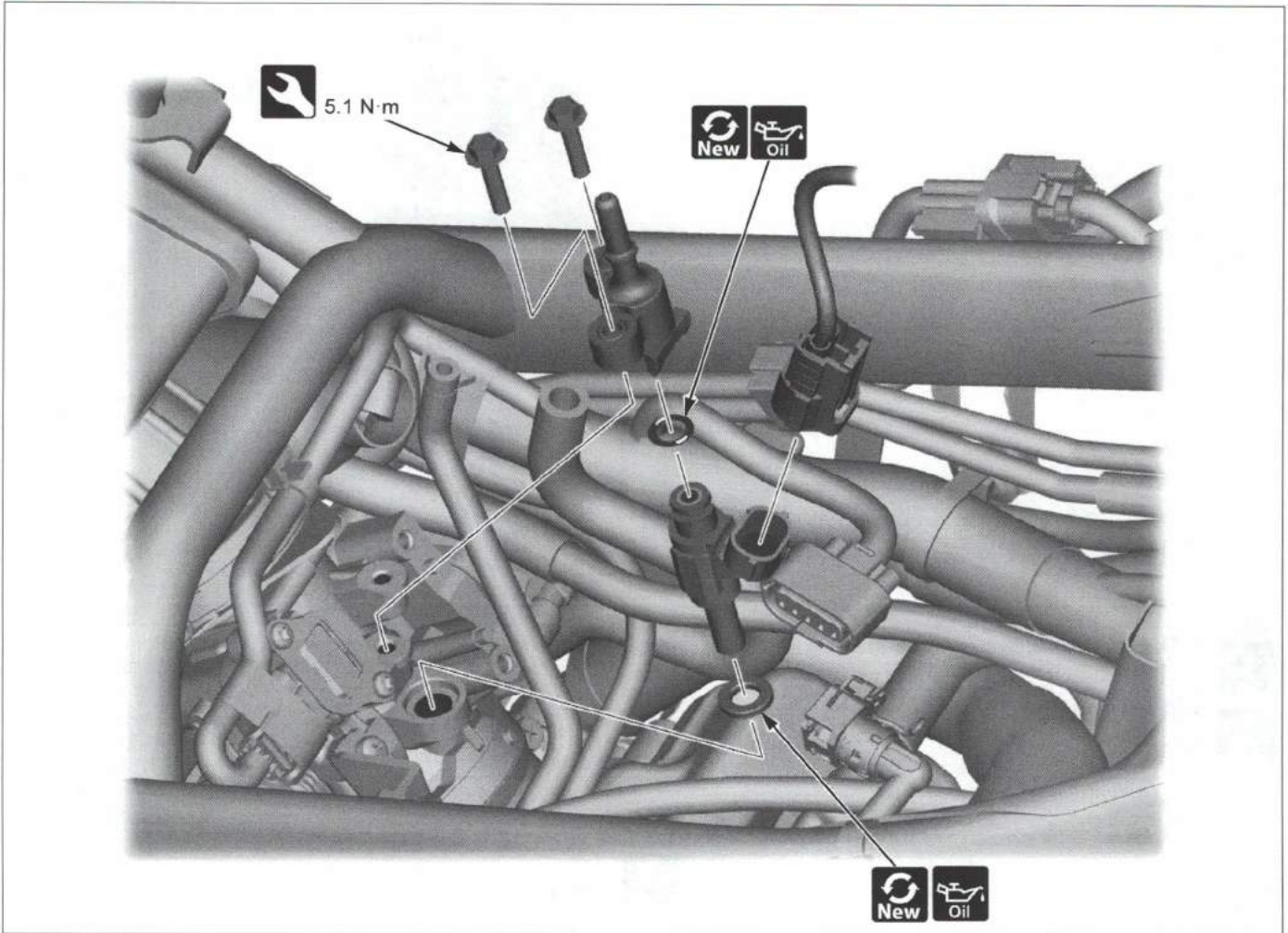

- Quick connect fitting (injector side) → 2-2



SECONDARY AIR SUPPLY SYSTEM

AC1734P

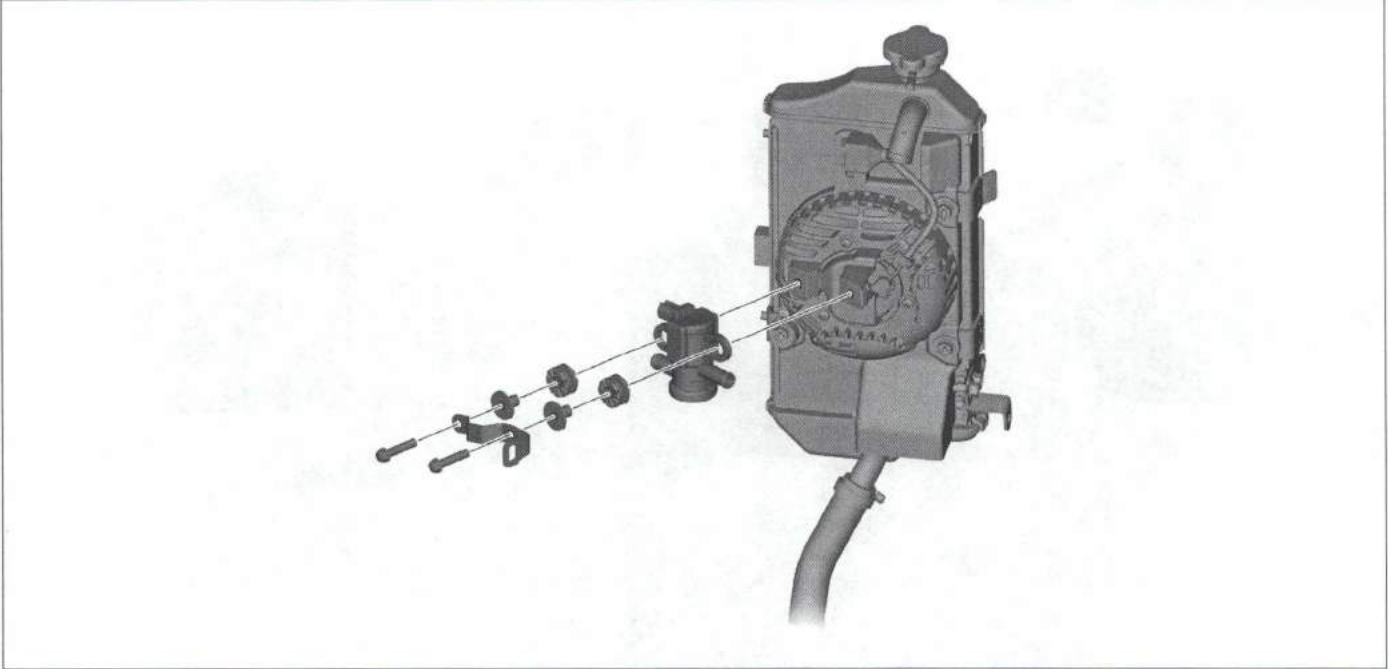

• Radiator with its hoses connected →2-18



Basic

• PAIR control solenoid valve inspection

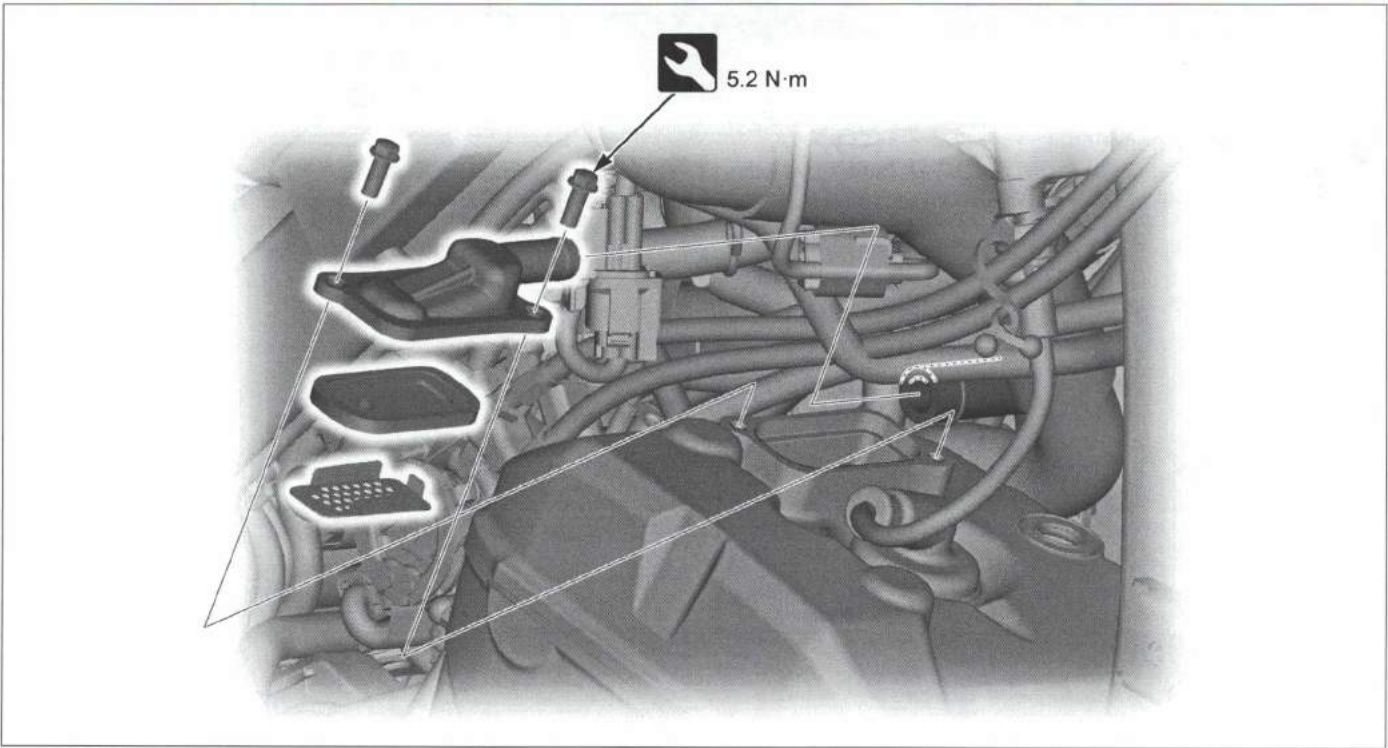

5.2 N-m



• Radiator with its hoses connected and cooling fan →2-18



Basic

• PAIR check valve inspection



EVAP SYSTEM (AC type)

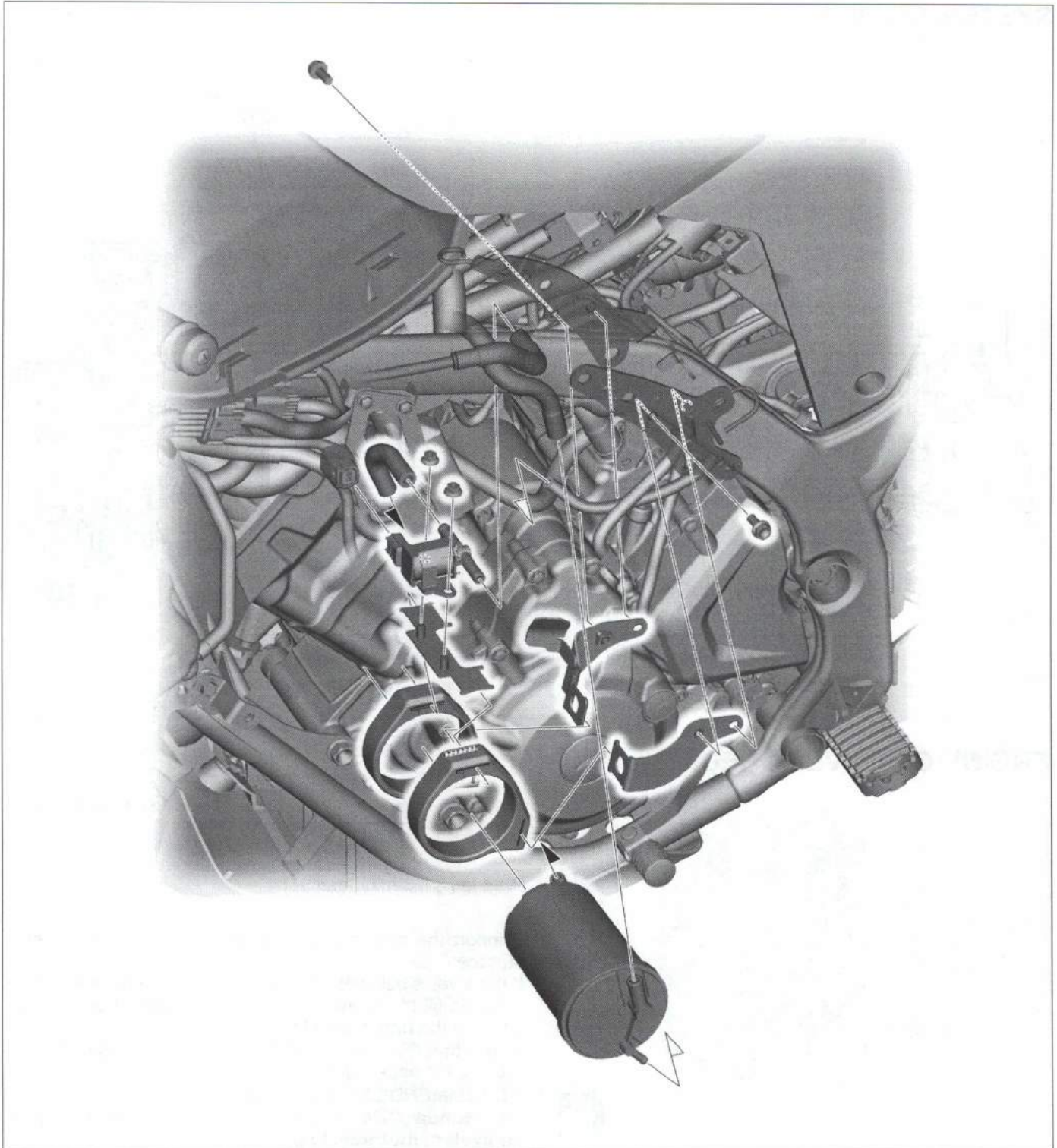

• Fuel tank shroud → 3-13



LUBRICATION SYSTEM SYSTEM DIAGRAM

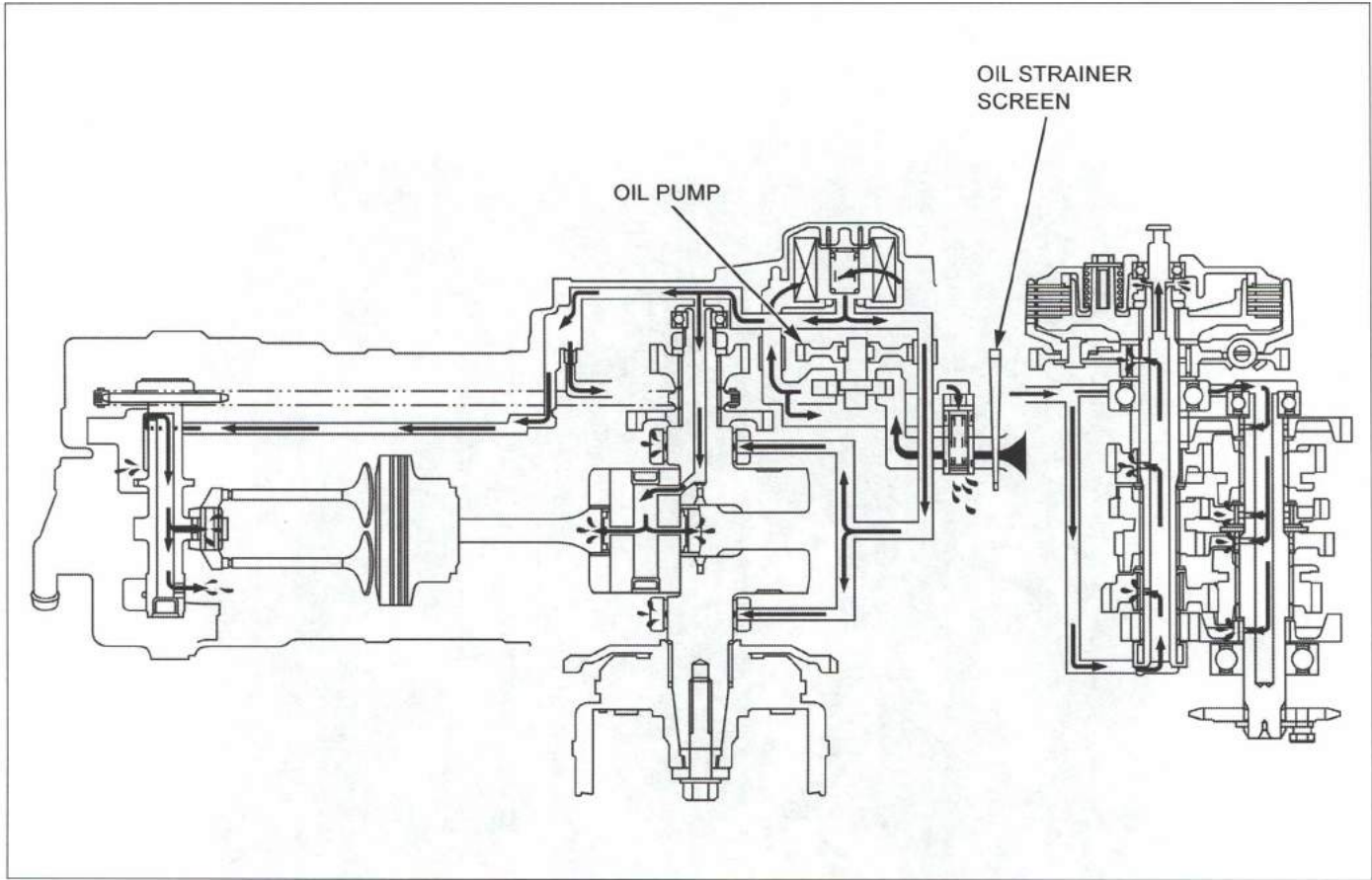

ENGINE OIL LEVEL CHECK

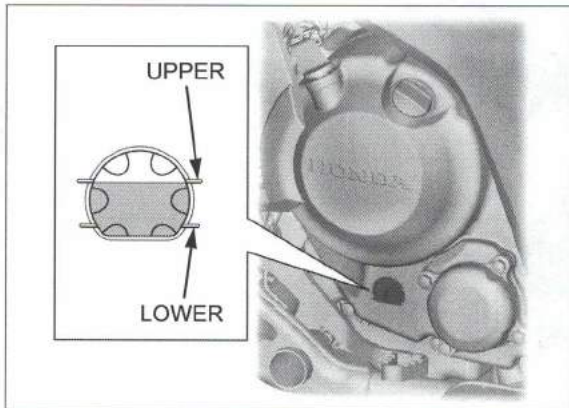

- Place the vehicle on the level ground with its sidestand.
- Let it idle for 3 – 5 minutes.
- Wait for 2 – 3 minutes.
- Support the motorcycle in an upright position on a level surface.
- If the level is below the lower level line, remove the oil filler cap and fill the crankcase with the recommended engine oil up to the upper level line.
- Check that the O-ring on the filler cap is in good condition, replace it if necessary.
- **RECOMMENDED ENGINE OIL:**
Pro Honda GN4 4-stroke oil (U.S.A. & Canada) or equivalent motorcycle oil
API service classification: SJ or higher
JASO T903 standard: MA
Viscosity: SAE 10W-30



ENGINE OIL CHANGE



- Drain oil completely.



- Fill the crankcase with the recommended engine oil.



- **ENGINE OIL CAPACITY:**
1.4 liter after draining
1.5 liter after oil filter change
1.8 liter after disassembly

ENGINE OIL FILTER CHANGE

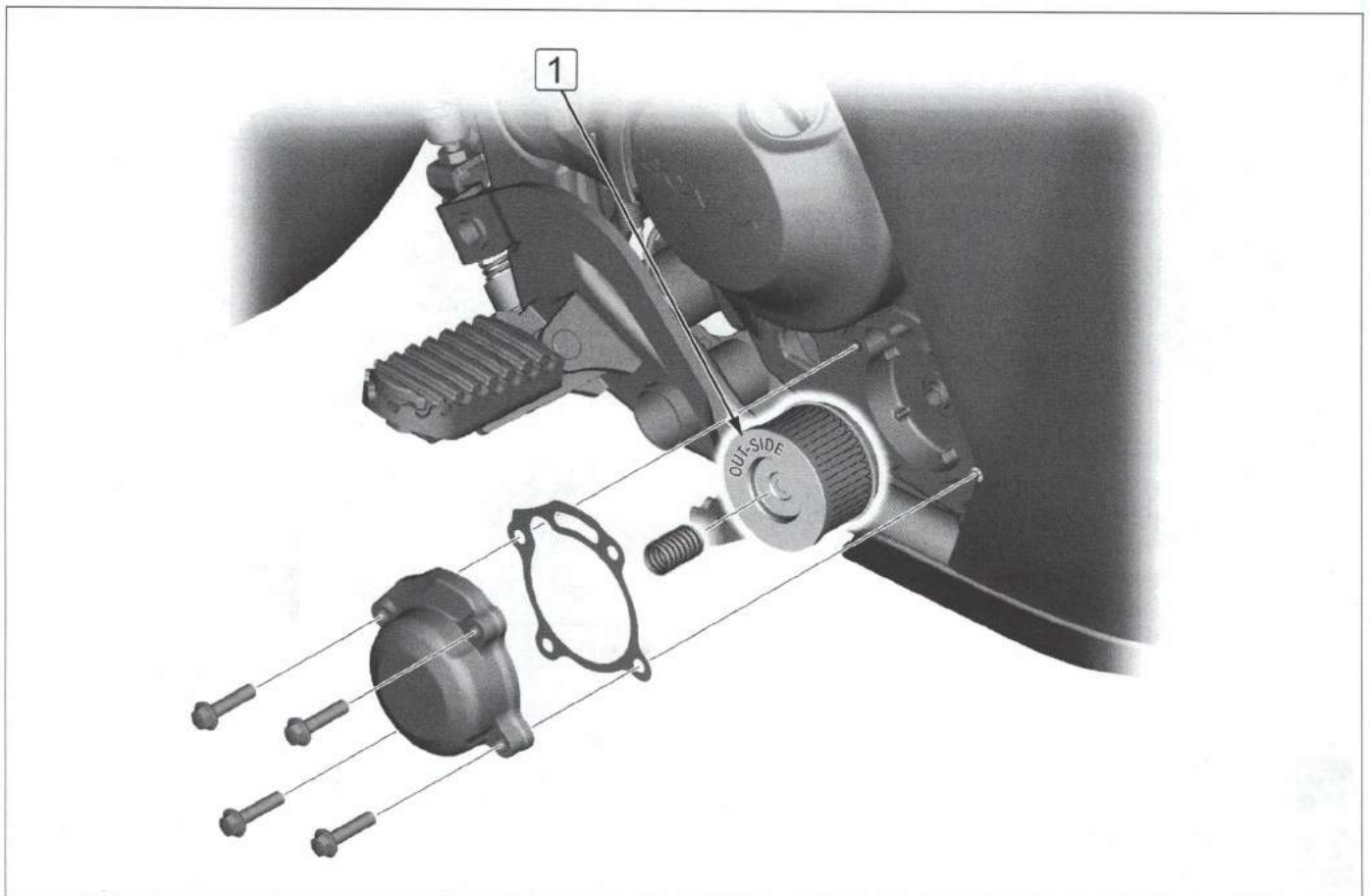

- **1** Install the oil filter with the "OUT-SIDE" mark facing out.
- Installing the oil filter backwards will result in severe engine damage.



- Engine oil filter inspection

Basic



ENGINE OIL STRAINER SCREEN/OIL PUMP

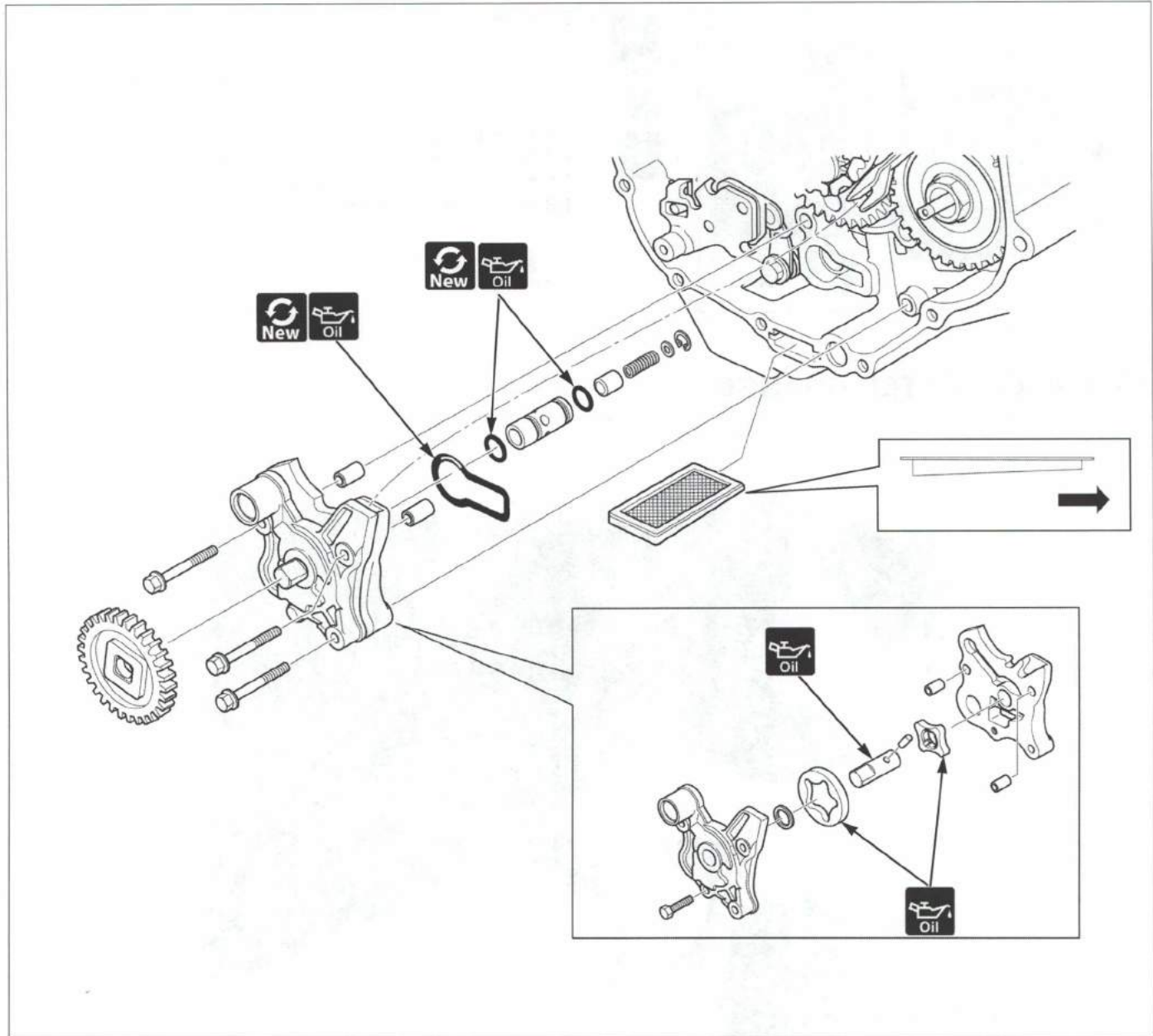

• Right crankcase cover →2-30



• Oil pump inspection

Basic



COOLING SYSTEM SYSTEM DIAGRAM

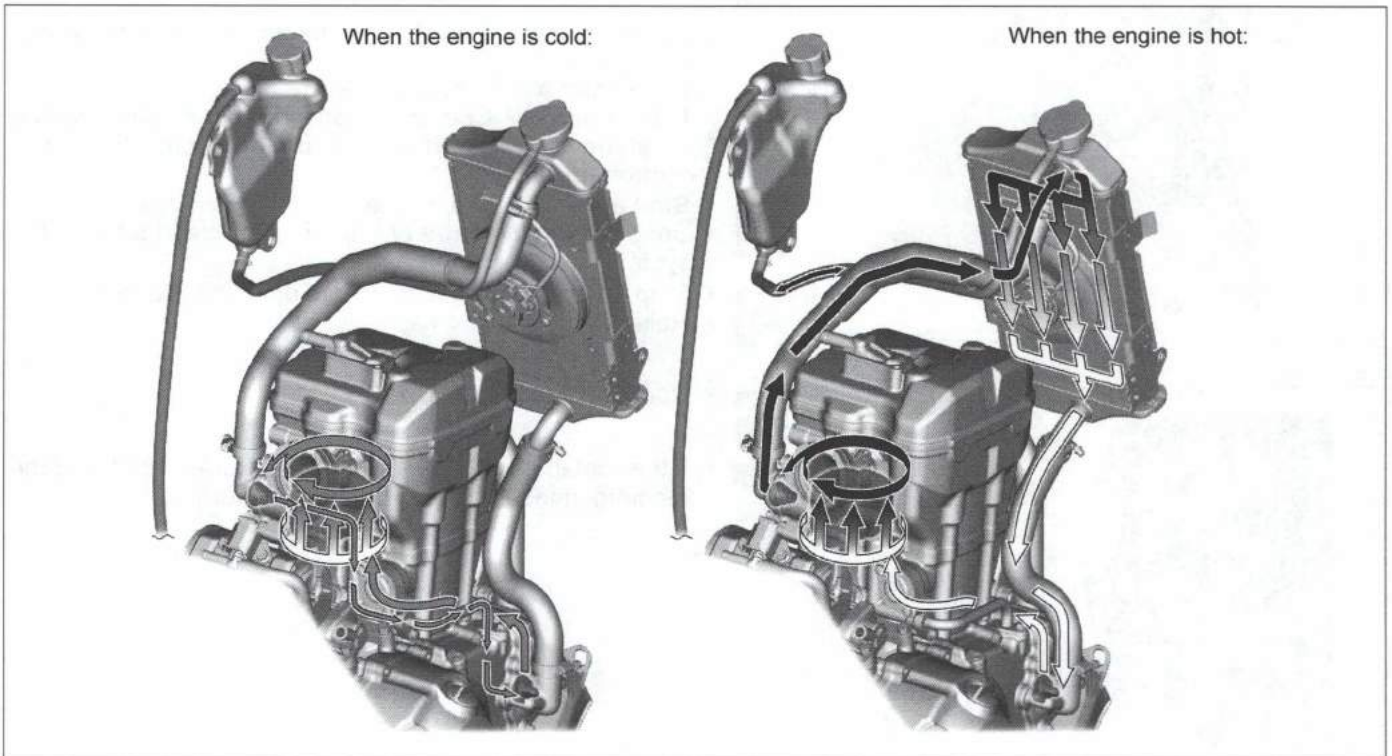

COOLANT REPLACEMENT

Coolant drain

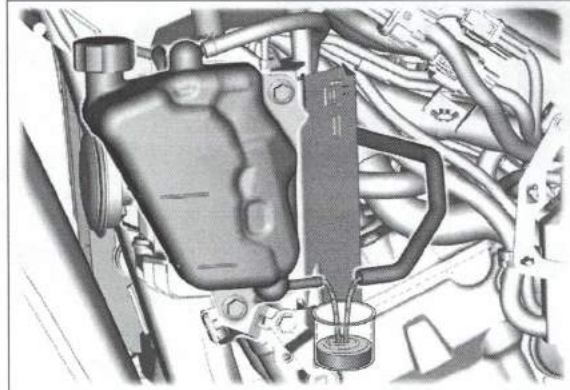
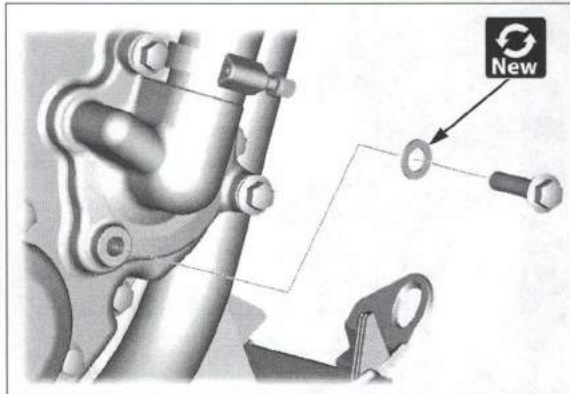

- Cooling system testing and inspection



- Fuel tank shroud → 3-13
- Radiator cap
- Coolant from the system



- Siphon hose from the filler neck
- Coolant from the reserve tank



FUEL & ENGINE

Air bleeding/Adding

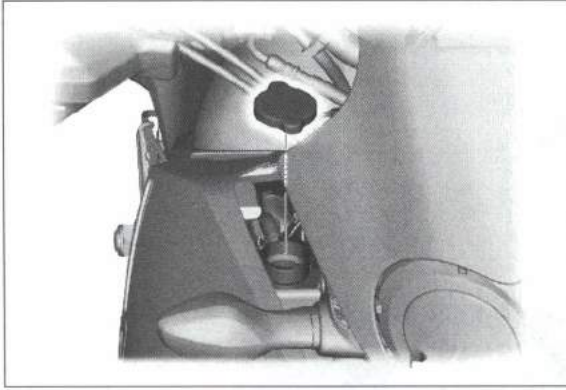

- Fuel tank shroud → 3-13

- Fill the system with the coolant through the filler opening to the filler neck.

RECOMMENDED ANTIFREEZE:

Pro Honda HP Coolant or an equivalent high quality ethylene glycol antifreeze containing corrosion protection inhibitors



- Start the engine and let it idle for 2 – 3 minutes.
- Snap the throttle three or four times to bleed air from the system.



- Stop the engine and add coolant up to the filler neck.
- Reinstall the radiator cap.

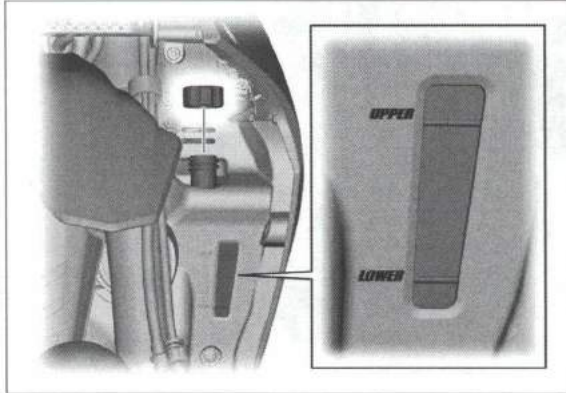

- Radiator reserve tank cap.



- If the coolant level is below or near the lower level, add the recommended coolant to the upper level line.

RADIATOR/COOLING FAN

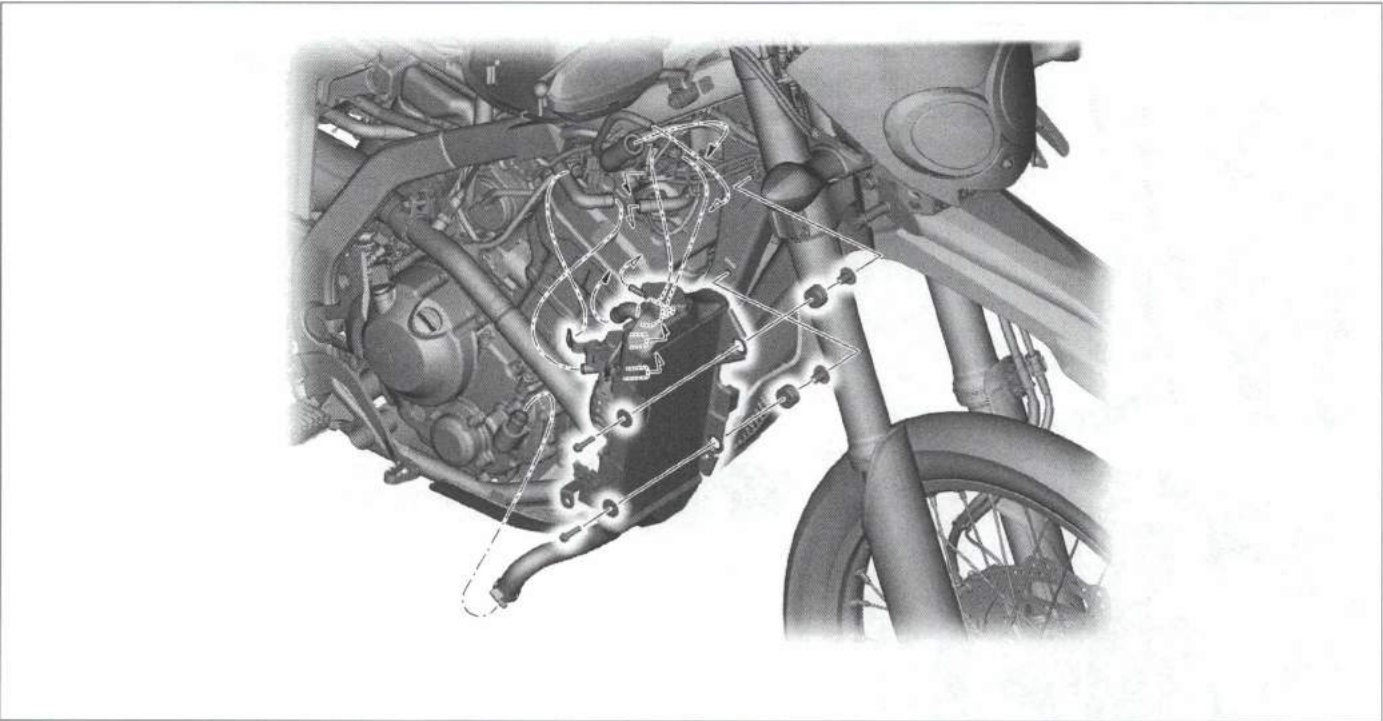

- Coolant → 2-17

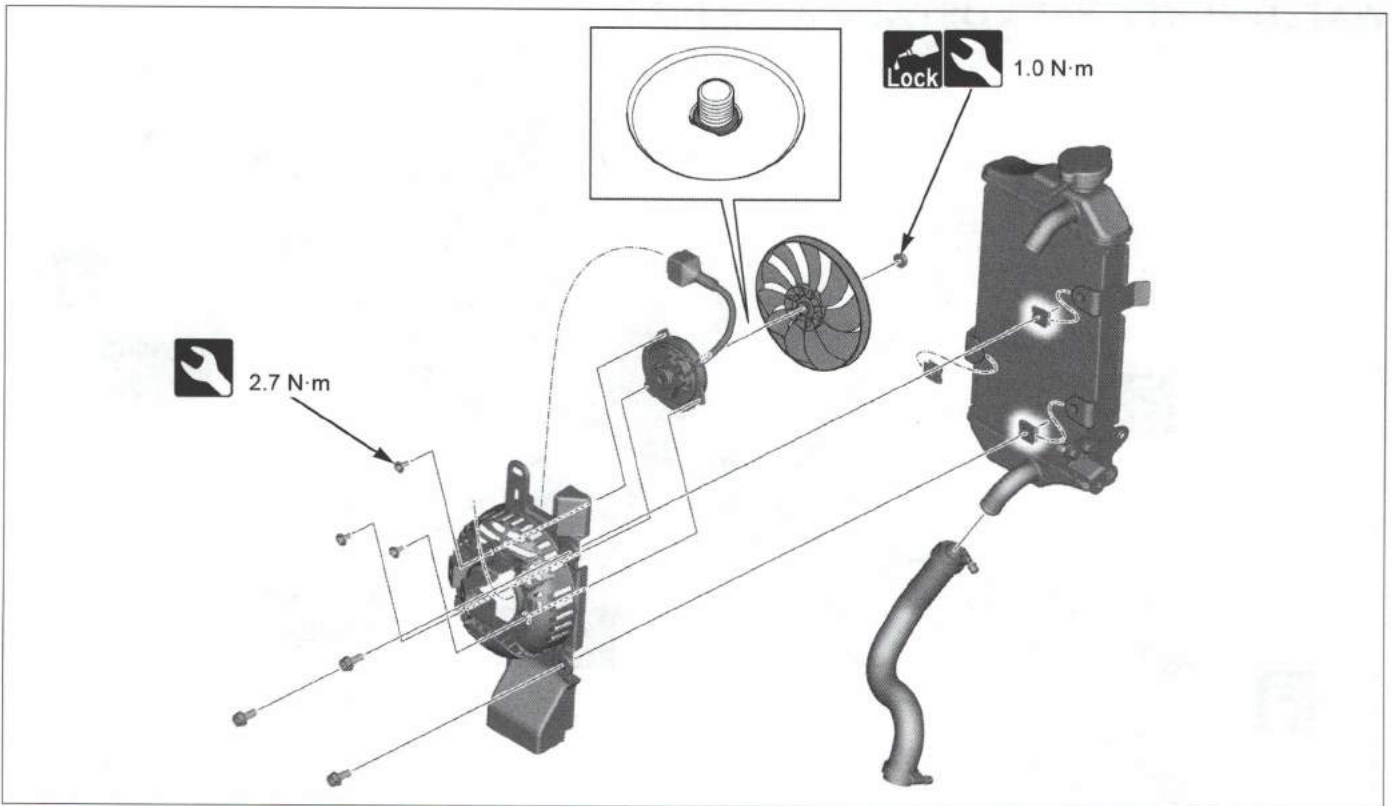

RADIATOR RESERVE TANK

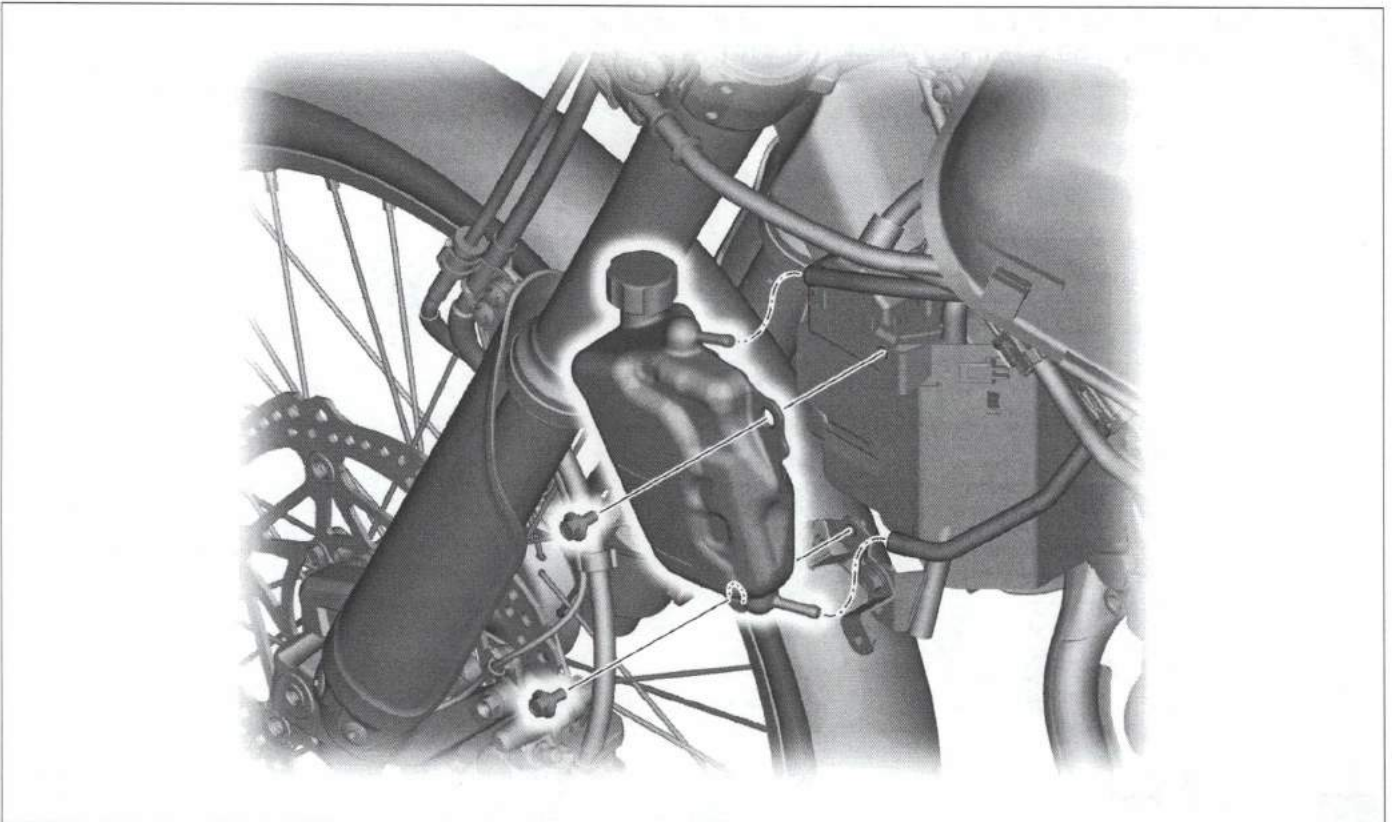

• Left fuel tank shroud → 3-13



WATER PUMP/THERMOSTAT/WATER PIPE

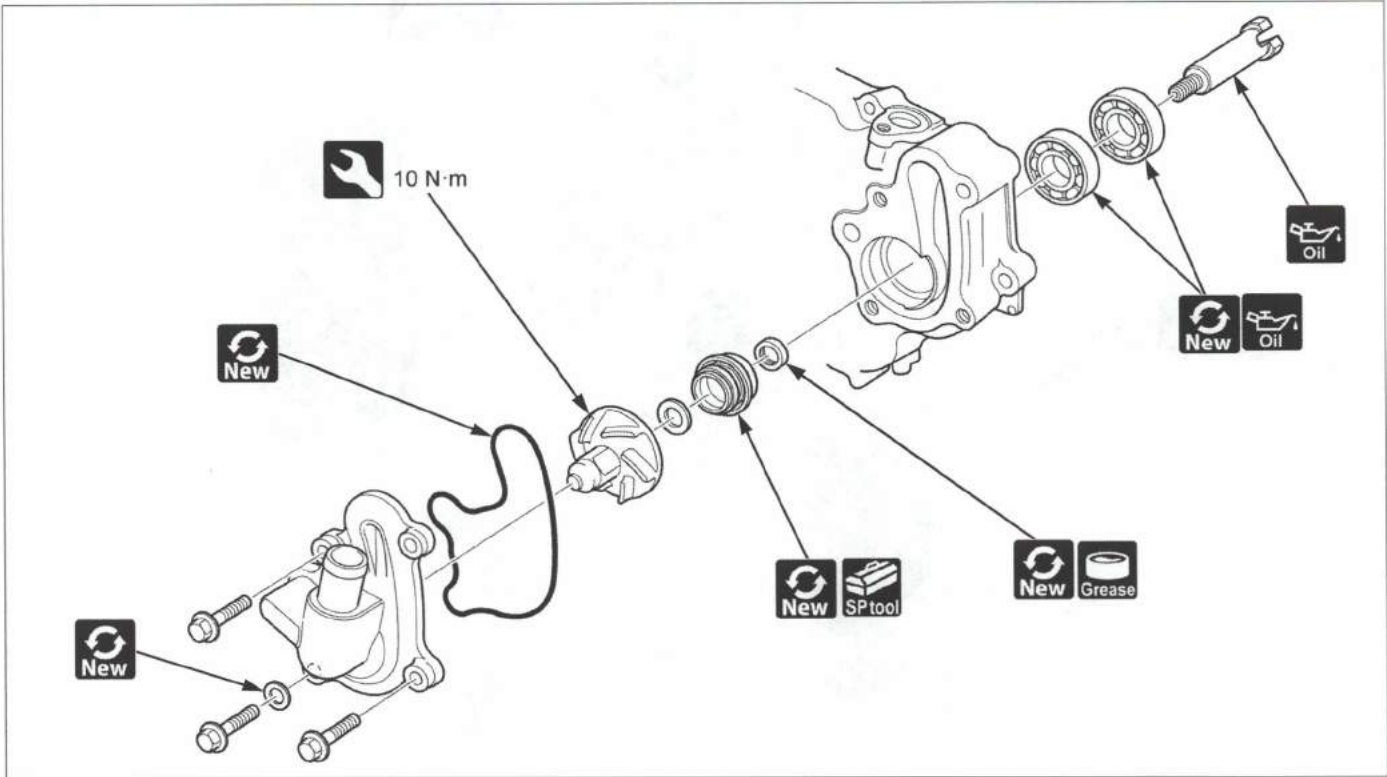

- Right crankcase cover →2-30
- Press a new mechanical seal using the hydraulic press and special tool.
Oil seal driver 30 x 36 mm: 07HMF-KR10101

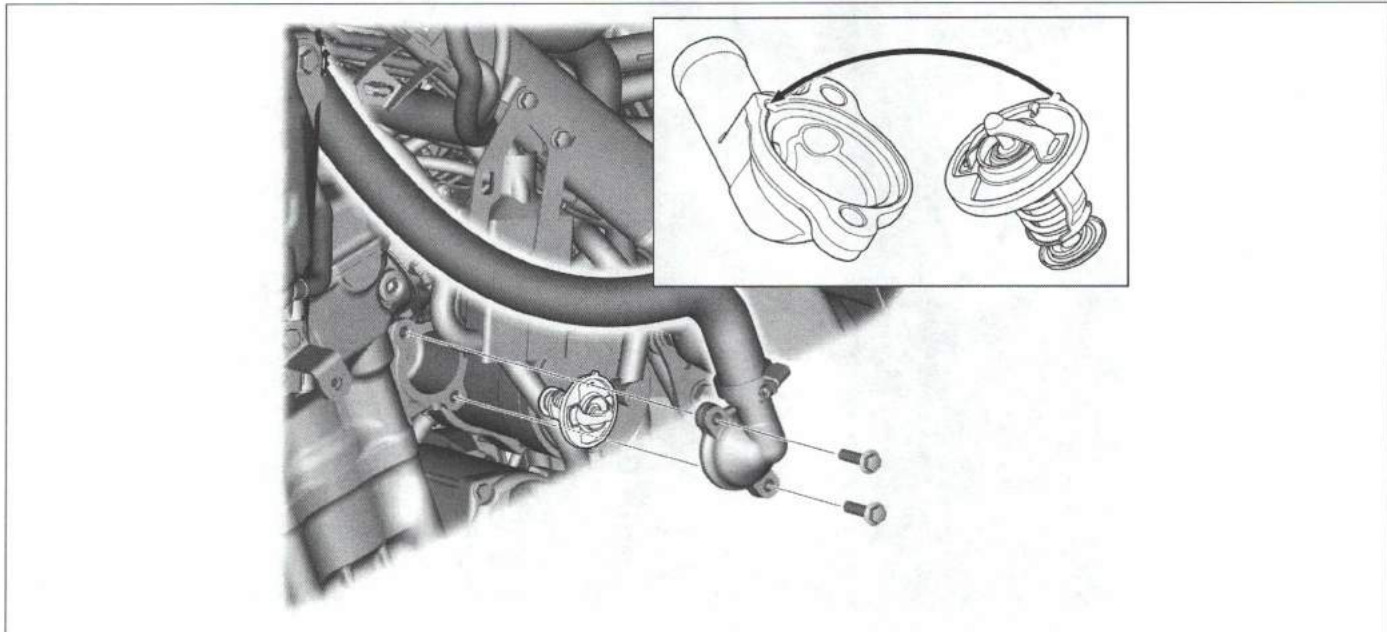

- Coolant →2-17
- Thermostat inspection



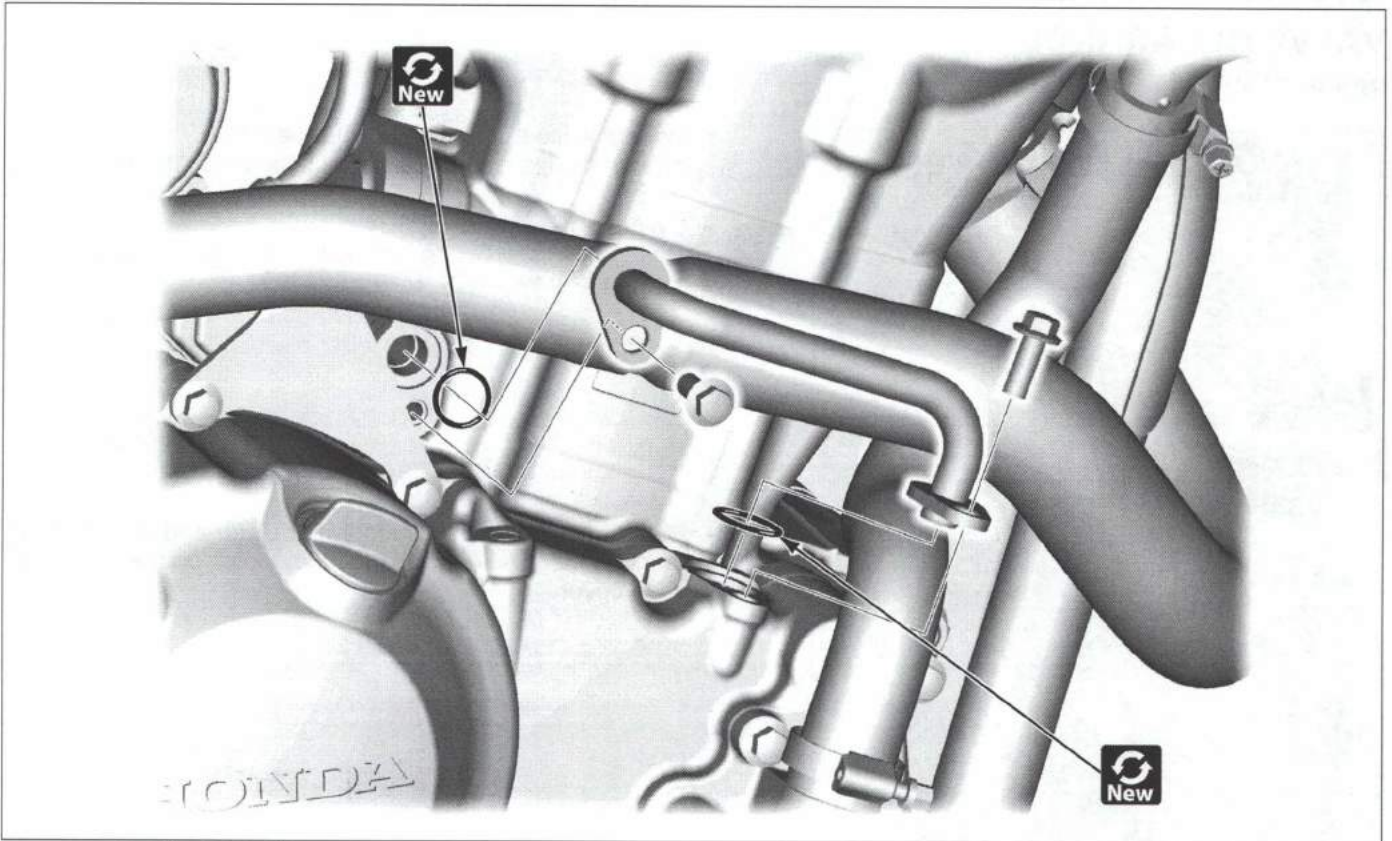

• Coolant →2-17



CYLINDER HEAD VALVE CLEARANCE INSPECTION

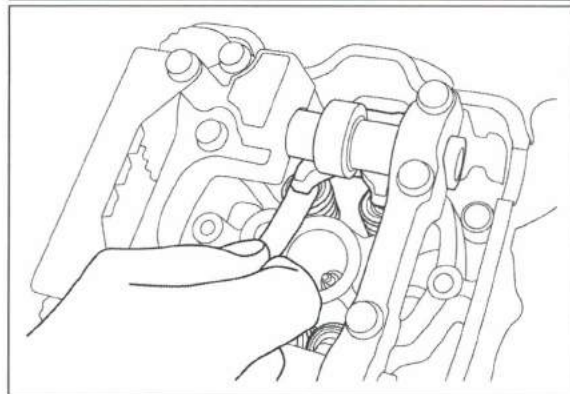
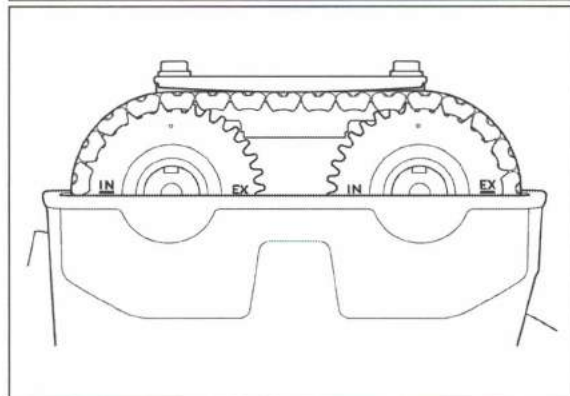
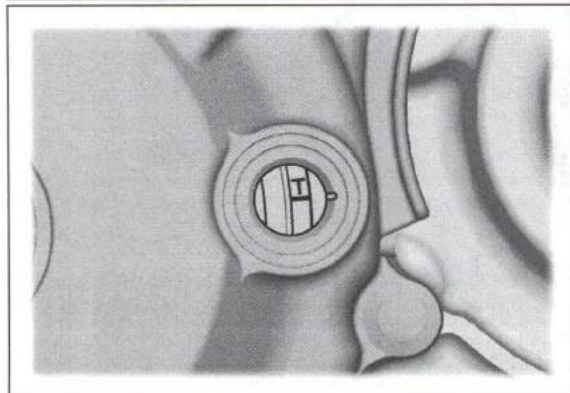
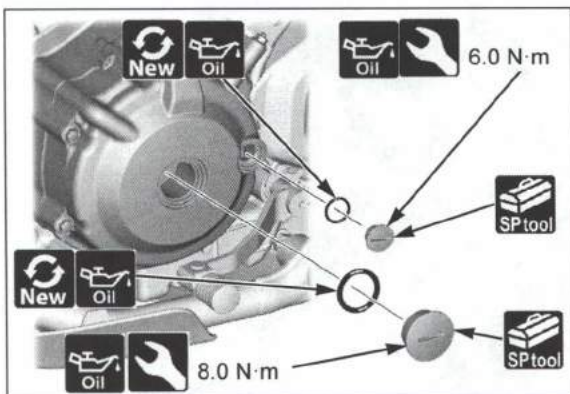

- Inspect while the engine is cold (below 35°C).
- After the valve clearance inspection, check the engine idle speed.
- Cylinder head cover → 2-24
- Timing hole cap/O-ring, crankshaft hole cap/O-ring
Timing cap wrench: 07709-0010001



- Rotate the crankshaft counterclockwise and align the "T" mark on the flywheel with the index notch on the left crankcase cover.

- The index lines on the cam sprockets must be flush with the cylinder head surface.
- Make sure the piston is at TDC (Top Dead Center) on the compression stroke.



- Valve clearance (Insert a feeler gauge between the rocker arm and shim).
IN: 0.16 ± 0.03 mm, EX: 0.27 ± 0.03 mm



ADJUSTMENT

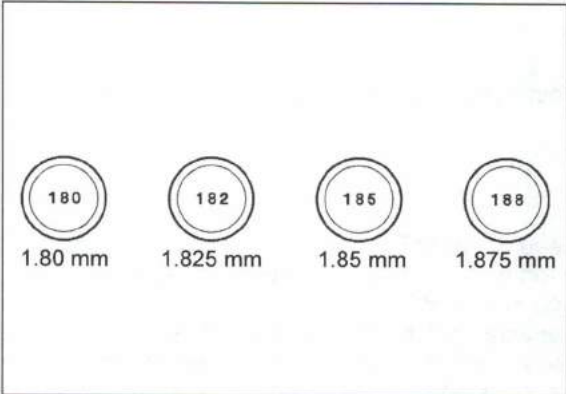
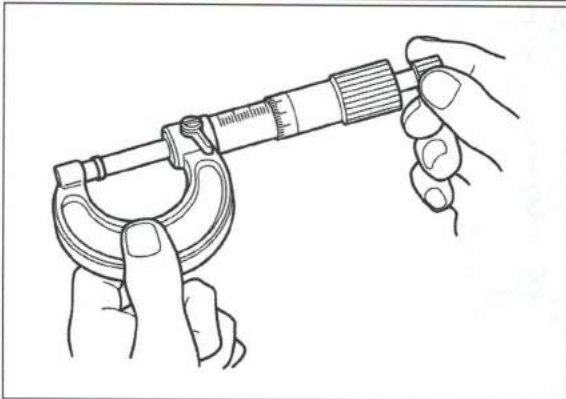
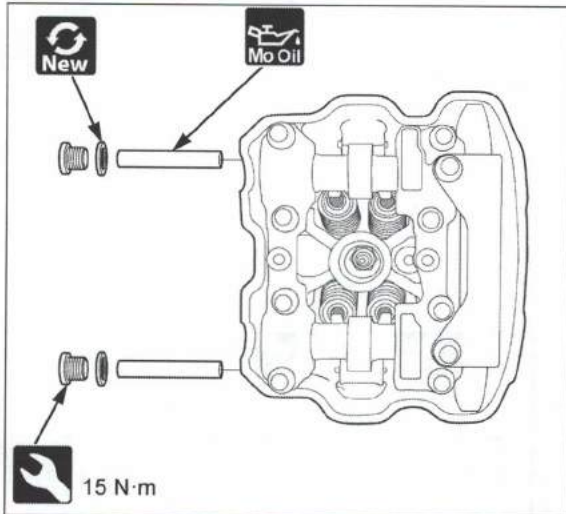

- Adjust while the engine is cold (below 35°C).
- Do not allow the shims to fall into the crankcase.
- Mark all shims to ensure correct reassembly in their original locations.
- The shims can be easily removed with tweezers or magnet.
- Cylinder head cover →2-24
- Bolt, sealing washer and rocker arm shaft
- Slide the rocker arm.
- Shims
- Clean the valve shim contact area with compressed air.



- Shim thickness and record it.



- Calculate the new shim thickness using the equation below.

$$A = (B - C) + D$$

A: New shim thickness

B: Recorded valve clearance

C: Specified valve clearance

D: Old shim thickness

- Fifty-seven different thickness shims are available from the thinnest 1.500 mm shim to the thickest 2.900 mm shim in intervals of 0.025 mm.
- Make sure of the correct shim thickness by measuring the shim by micrometer.
- Reface the valve seat if carbon deposit result in a calculated dimension of over 2.900 mm.
- Newly selected shim on the valve spring retainer.
- Removed parts
- Rotate the camshafts by rotating the crankshaft counterclockwise several times.
- Recheck the valve clearance →2-22



CYLINDER HEAD COVER

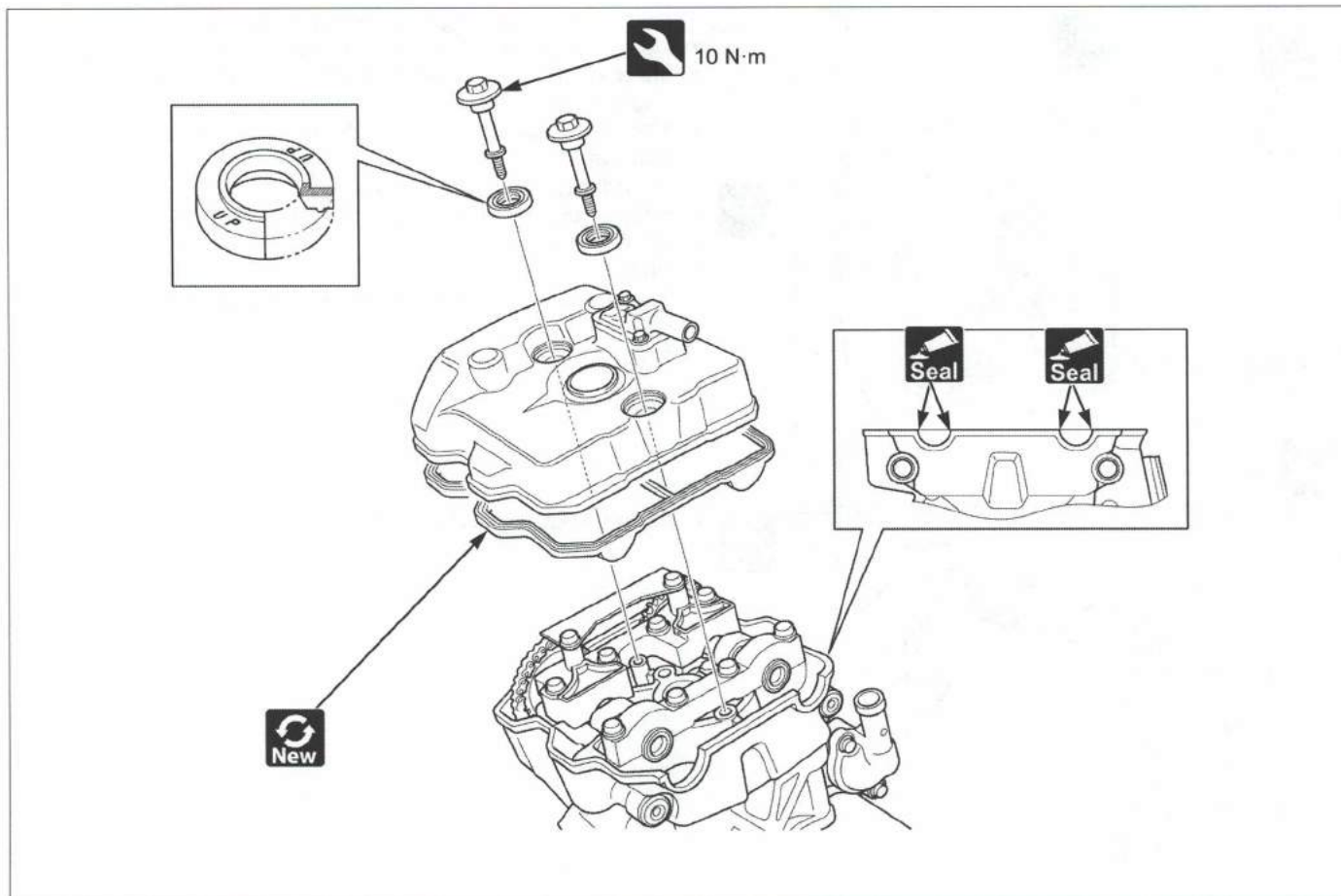

• Radiator with its hoses connected and cooling fan →2-18



• 1 Apply sealant (Three bond 5211C or 1207B or 1215 or Shin-Etsu Silicone KE45 or equivalent) to the cylinder head cover gasket semicircular corner.

CAMSHAFT/ROCKER ARM

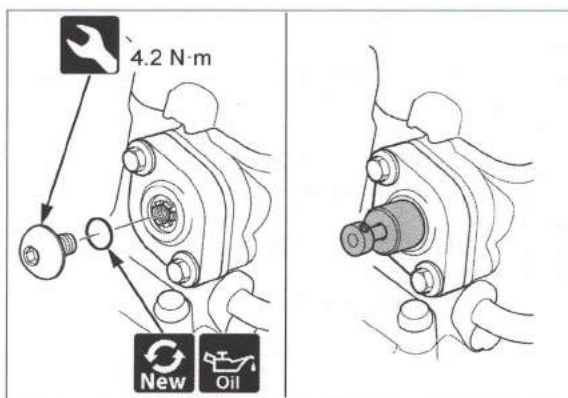

- Cylinder head cover →2-24
- Set the piston to the TDC (Top Dead Center) on the compression stroke →2-22
- Install the special tool into the tensioner body and turn the tool clockwise until it stops. Hold the tensioner lifter by pushing the tool while aligning the tabs of the tool with the grooves of the tensioner lifter.

Cam chain tensioner lifter stopper: 070MG-0010100

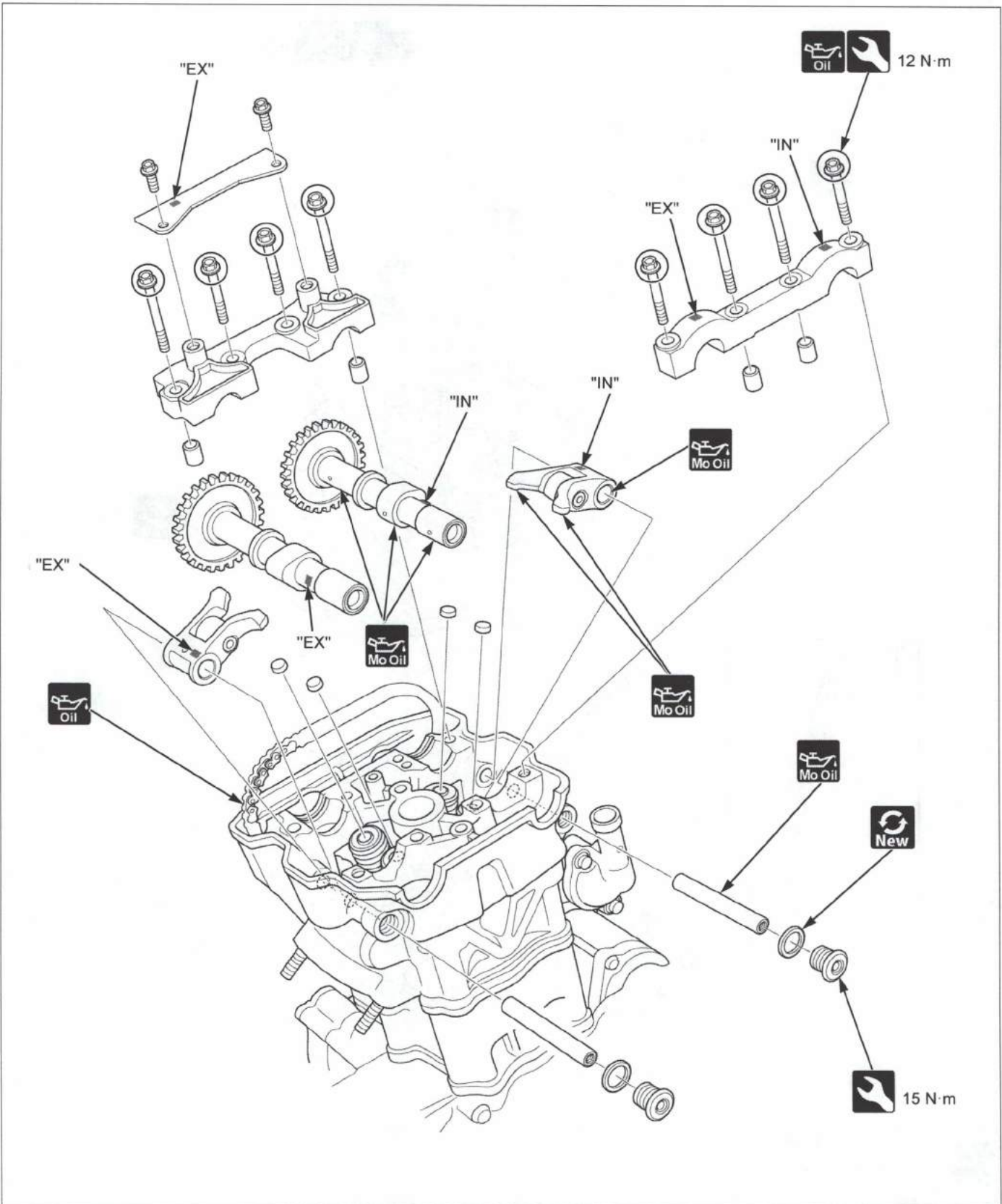

- Install each camshaft, rocker arm, camshaft holder and cam chain guide B to the correct position with the identification mark.



- Camshaft inspection
- Camshaft oil clearance inspection

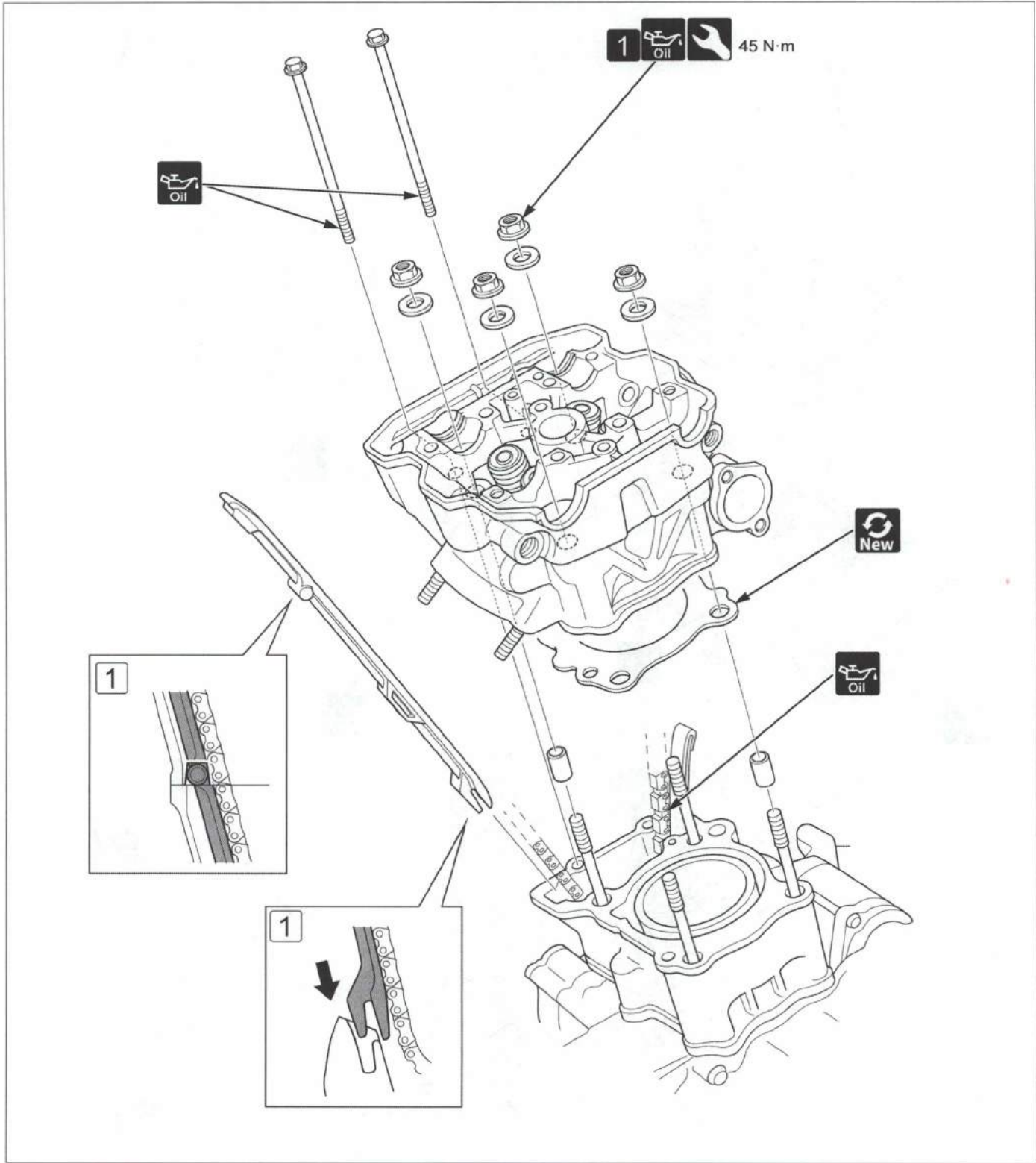

- Throttle body →2-8
- Camshaft →2-24
- Thermostat →2-20



- **1** Loosen the cylinder head nuts in a crisscross pattern in two or three steps.
- **1** Install the cam chain guide while aligning its pins with the grooves on the cylinder head and its end with the groove on the left crankcase.

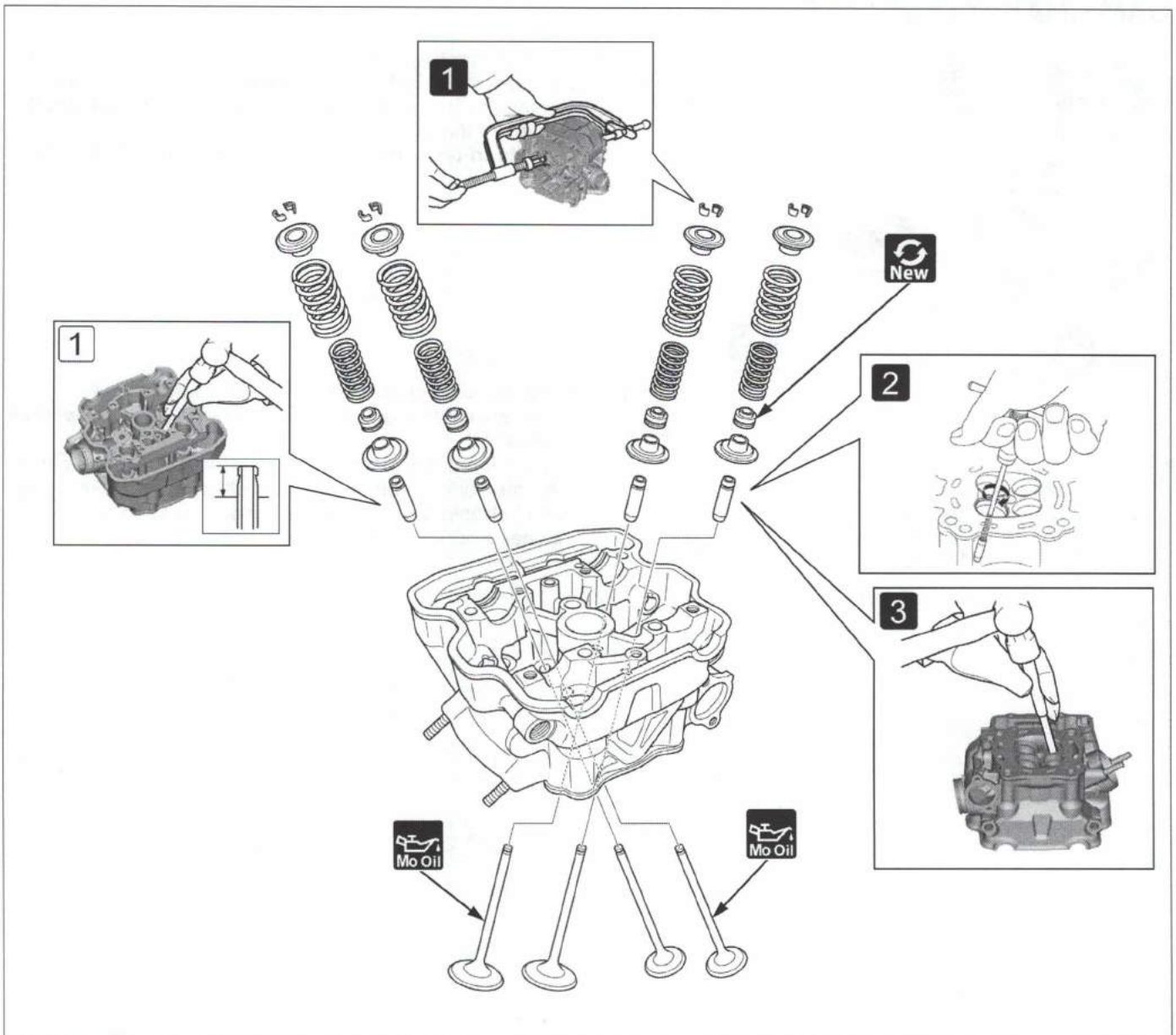

- **1** Remove the valve cotter.
Valve spring compressor: 07757-0010000
Valve spring compressor attachment: 07959-KM30101
- **2** Ream the valve guide to remove any carbon build up before measuring the guide. Insert the reamer from the combustion chamber side of the cylinder head and always rotate the reamer clockwise.
Valve guide reamer, 4.5 mm: 07HMH-ML00101
- **3** Support the cylinder head and drive the valve guides out of the cylinder head from the combustion chamber side.
Valve guide driver, 4.3 mm: 07HMD-ML00101



- **1** Drive new valve guides into the cylinder head to the specified height from the cylinder head.
INTAKE/EXHAUST VALVE GUIDE PROJECTION: 13.8 – 14.0 mm
Valve guide driver: 07743-0020000



- Valve and valve spring inspection
- Valve guide inspection
- Valve seat inspection



CAM CHAIN TENSIONER

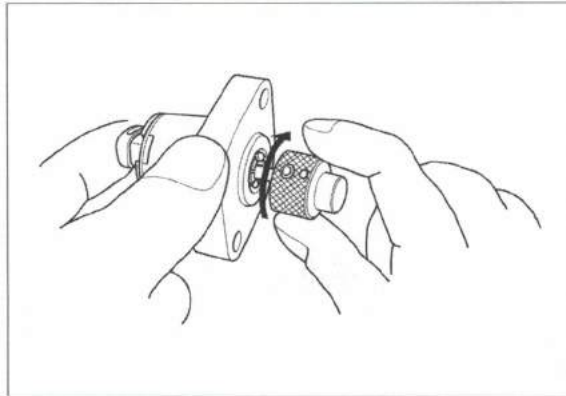
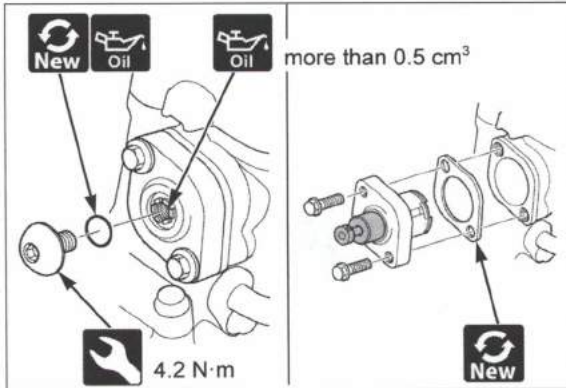

- Install the special tool into the tensioner body and turn the tool clockwise until it stops. Hold the tensioner lifter by pushing the tool while aligning the tabs of the tool with the grooves of the tensioner lifter.

Cam chain tensioner lifter stopper: 070MG-0010100



- Check the cam chain tensioner lifter operation:
 - The tensioner shaft should not go into the body when it is pushed.
 - When it is turned clockwise with the tensioner stopper, the tensioner shaft should be pulled into the body. The shaft should protrude from the body as soon as the tensioner stopper is released.



CYLINDER/PISTON

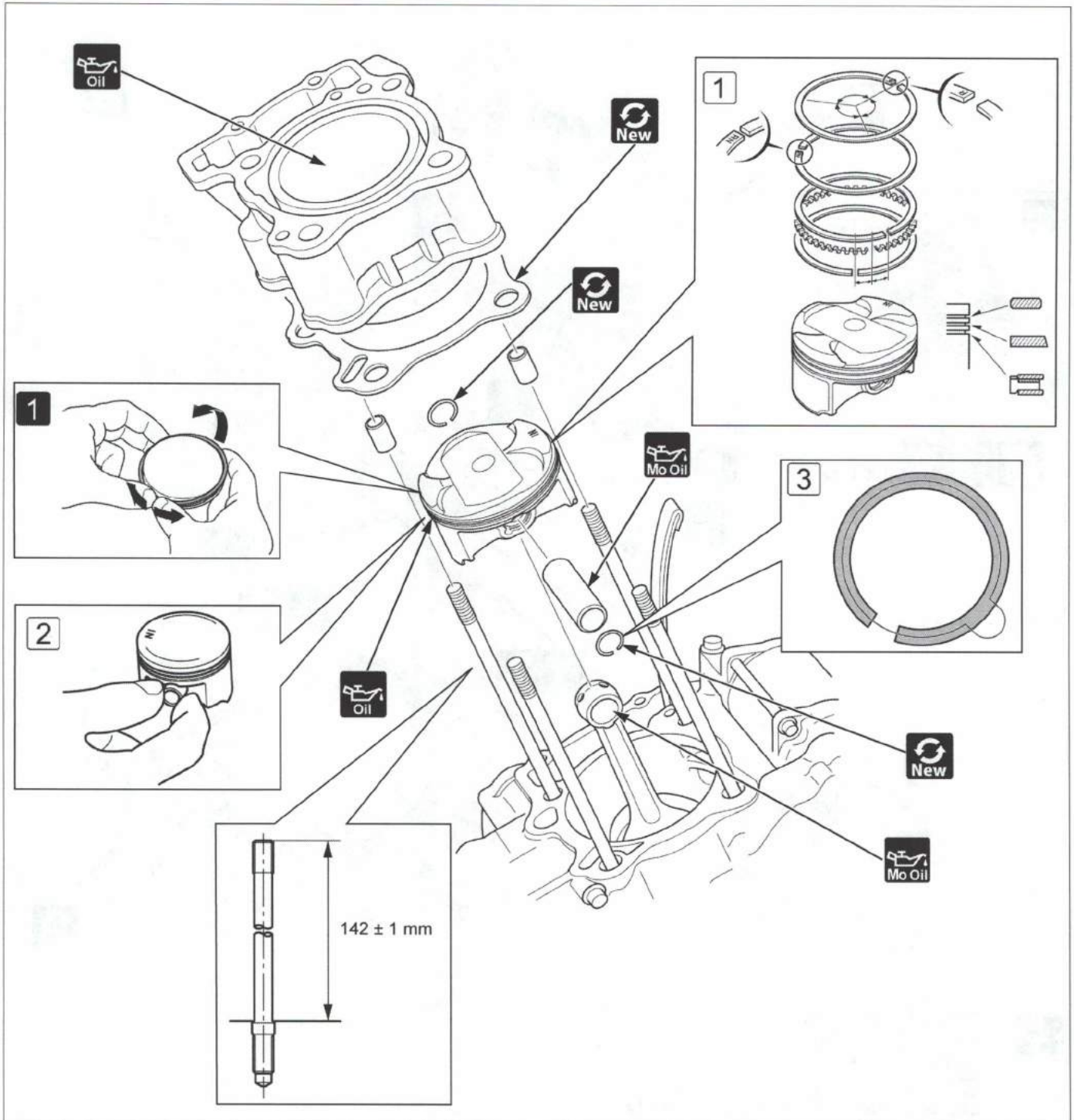

• Cylinder head →2-22



• Cam chain tensioner →2-28

• **1** Spread each piston ring and remove it by lifting up at a point opposite the gap.

• **1** Carefully install the piston rings into the piston ring grooves with the markings facing up.

• **2** Install the piston with the "IN" mark facing the intake side.

• **3** Do not align the piston pin clip end gap with the piston cut-out.



• Piston and piston rings inspection

• Cylinder inspection



CLUTCH/GEARSHIFT LINKAGE

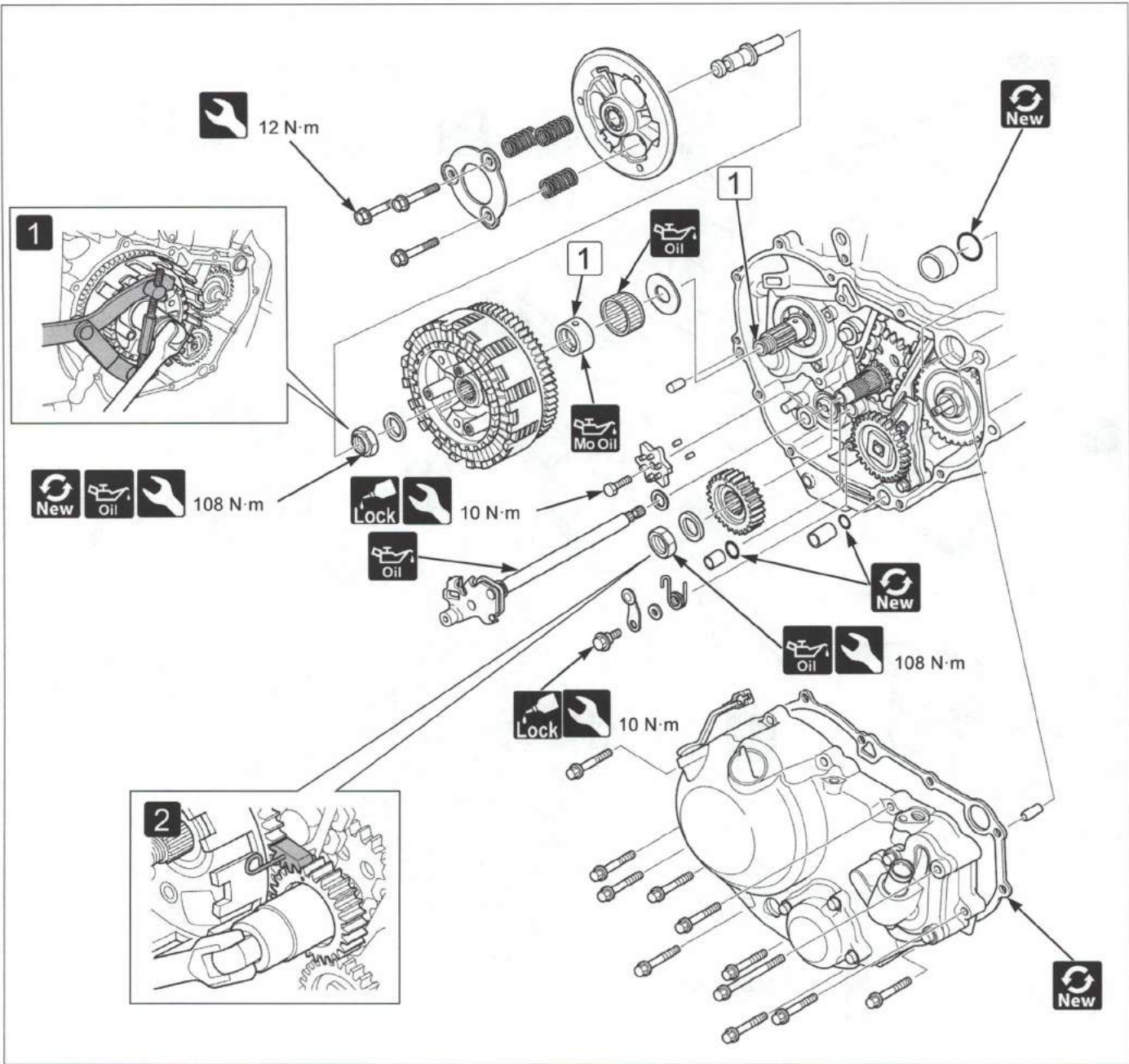

• Gearshift pedal →3-16

• Water pipe →2-20

• Brake pedal →3-10

• **1** Loosen the clutch center lock nut.
Clutch center holder: 07724-0050002

• **2** Hold the flywheel and loosen the primary drive gear lock nut.
Gear holder, M1.5: 07724-0010200



• **1** The mainshaft and clutch outer guide has ID color paint mark. When the clutch outer assembly is replaced, be sure to selecting same color codes of the mainshaft and clutch outer guide.

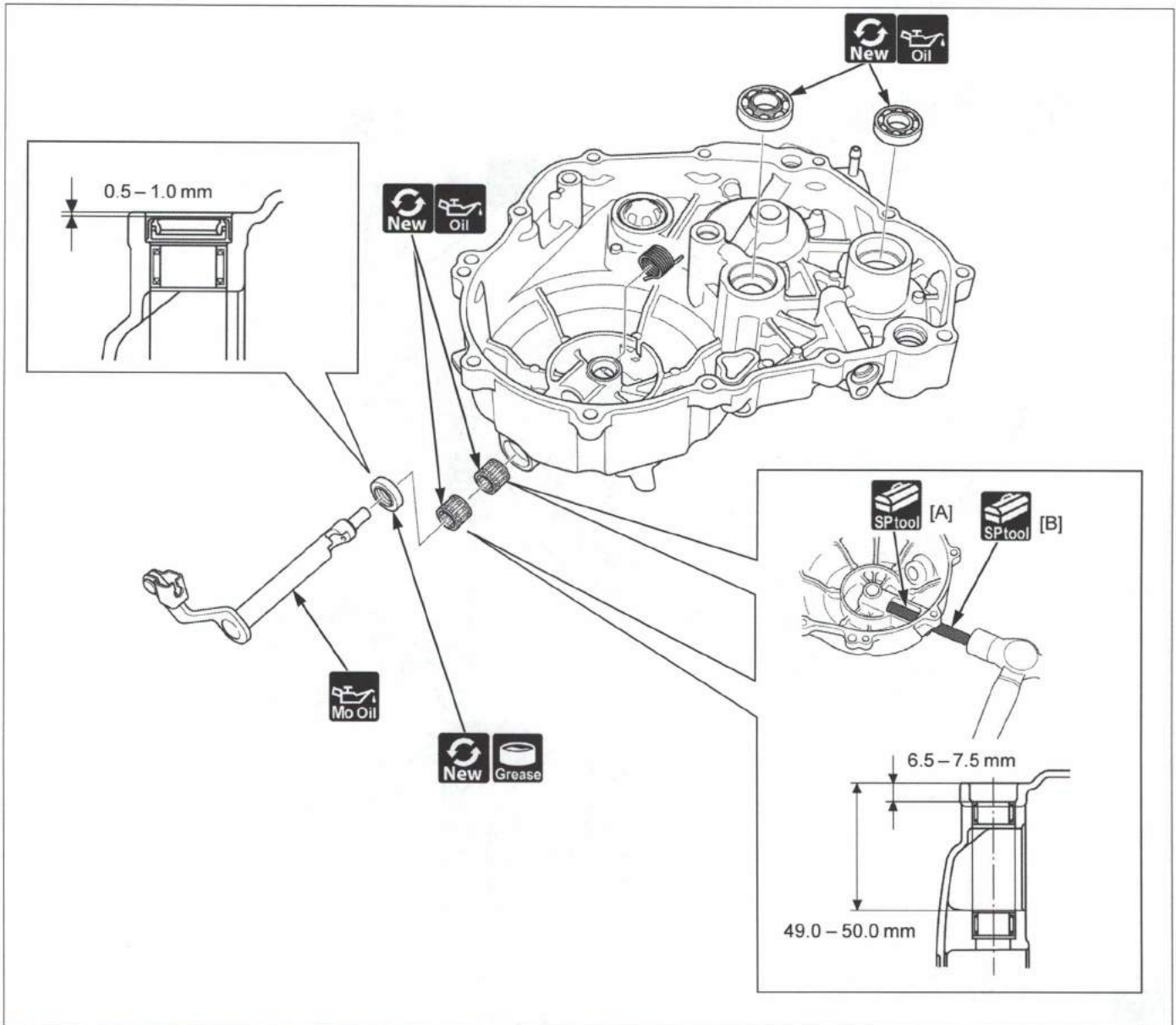

- CLUTCH LIFTER ARM NEEDLE BEARING:
 [A] Pilot collar, 16 mm: 07PAF-0010620 [B] Bearing remover head, 10 mm: 07746-0050200

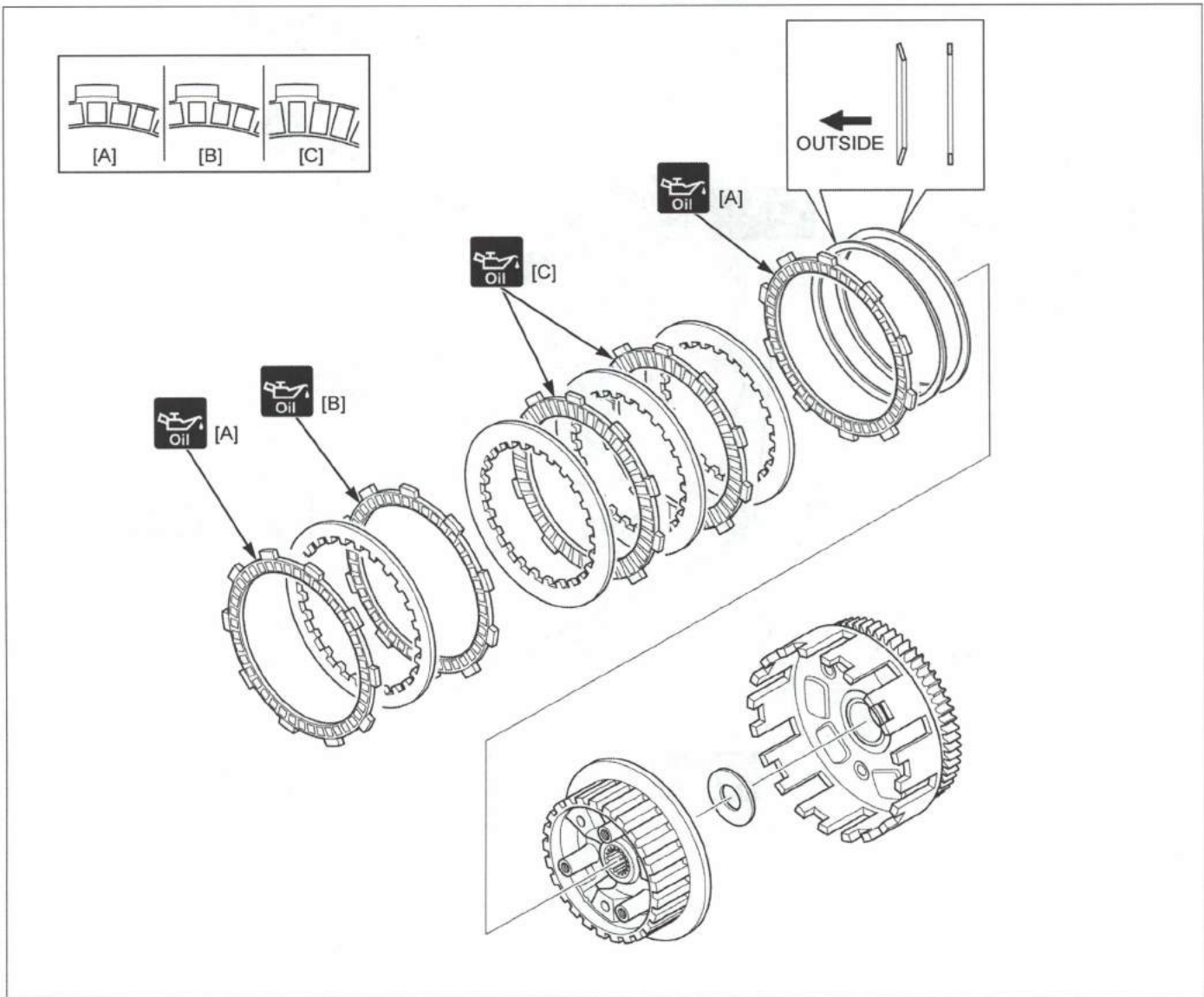

• Clutch inspection



ALTERNATOR/STARTER CLUTCH

- This service can be performed with the engine installed in the frame.

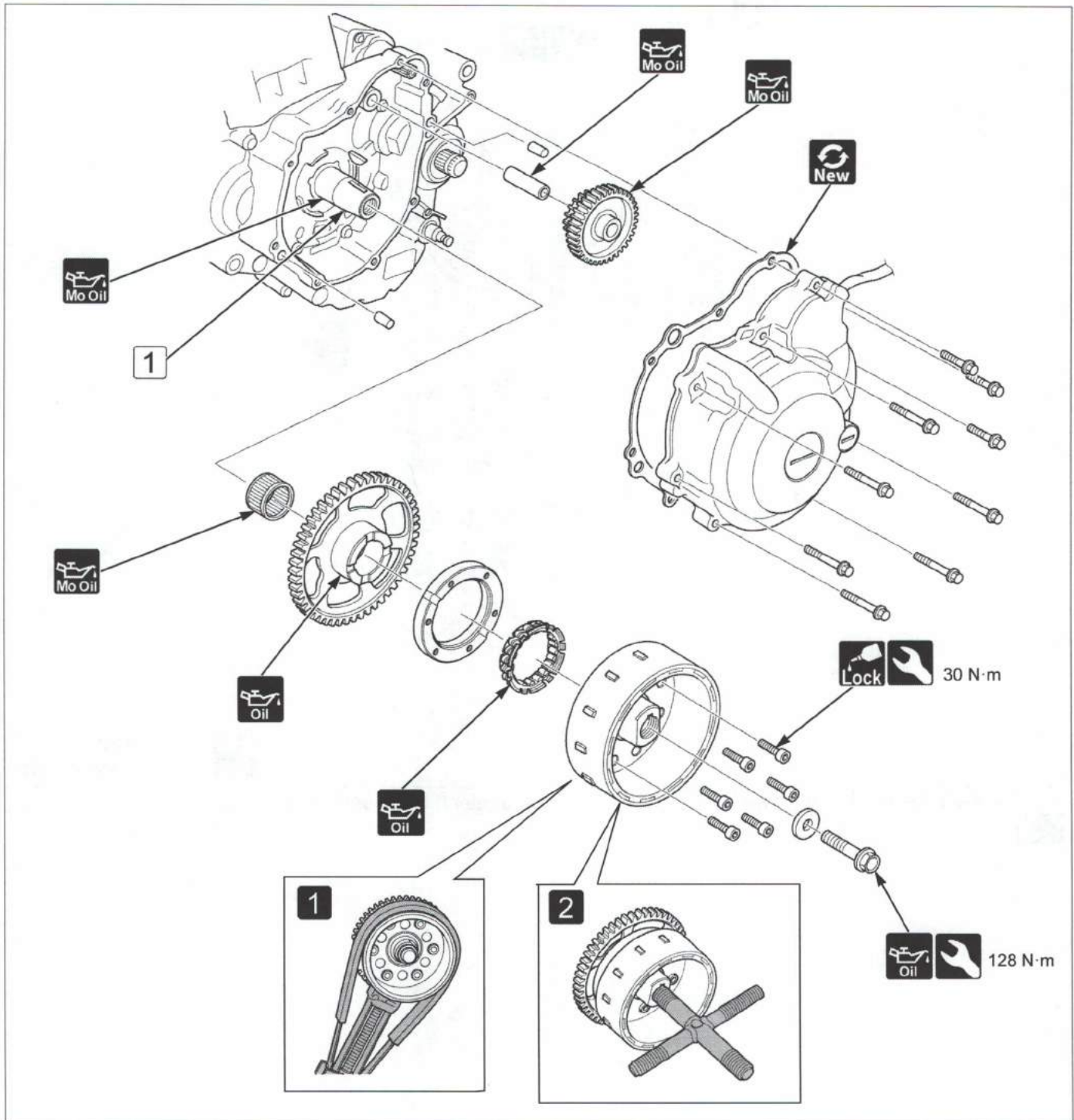

- Under cowl → 3-7
- Drive sprocket cover → 3-16
- **1** Hold the flywheel with the special tool for the bolt removal.
Flywheel holder: 07725-0040001
- **2** Flywheel
Flywheel puller: 07733-0020001



- **1** Clean any oil and grease from crankshaft and flywheel contact area.

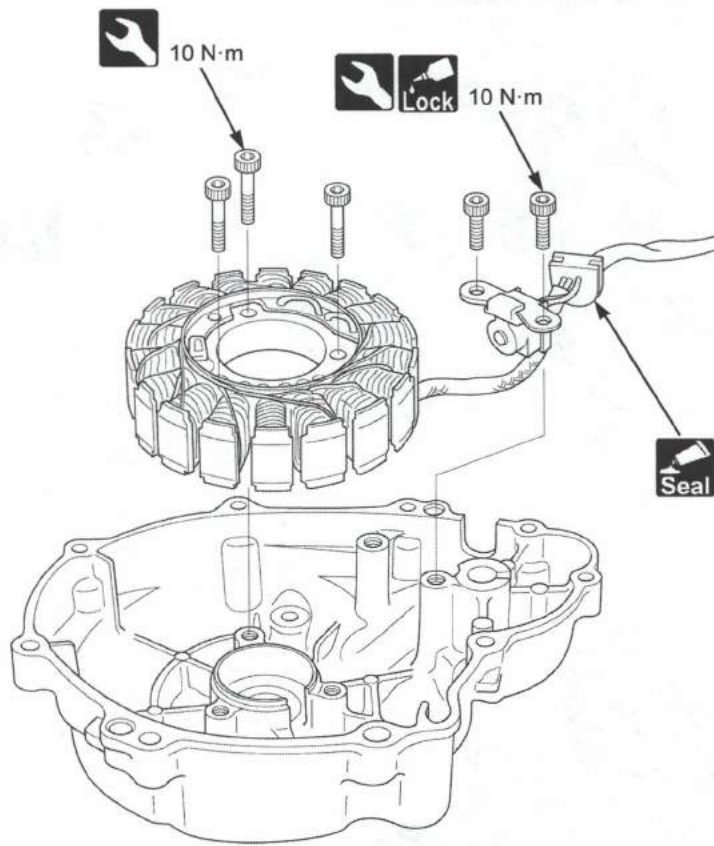

Coating width:
6.5 ± 1 mm from the tip



- Apply liquid sealant (Three bond 1207B, 1215 or equivalent) to the semicircular area.



CRANKCASE/CRANKSHAFT/BALANCER

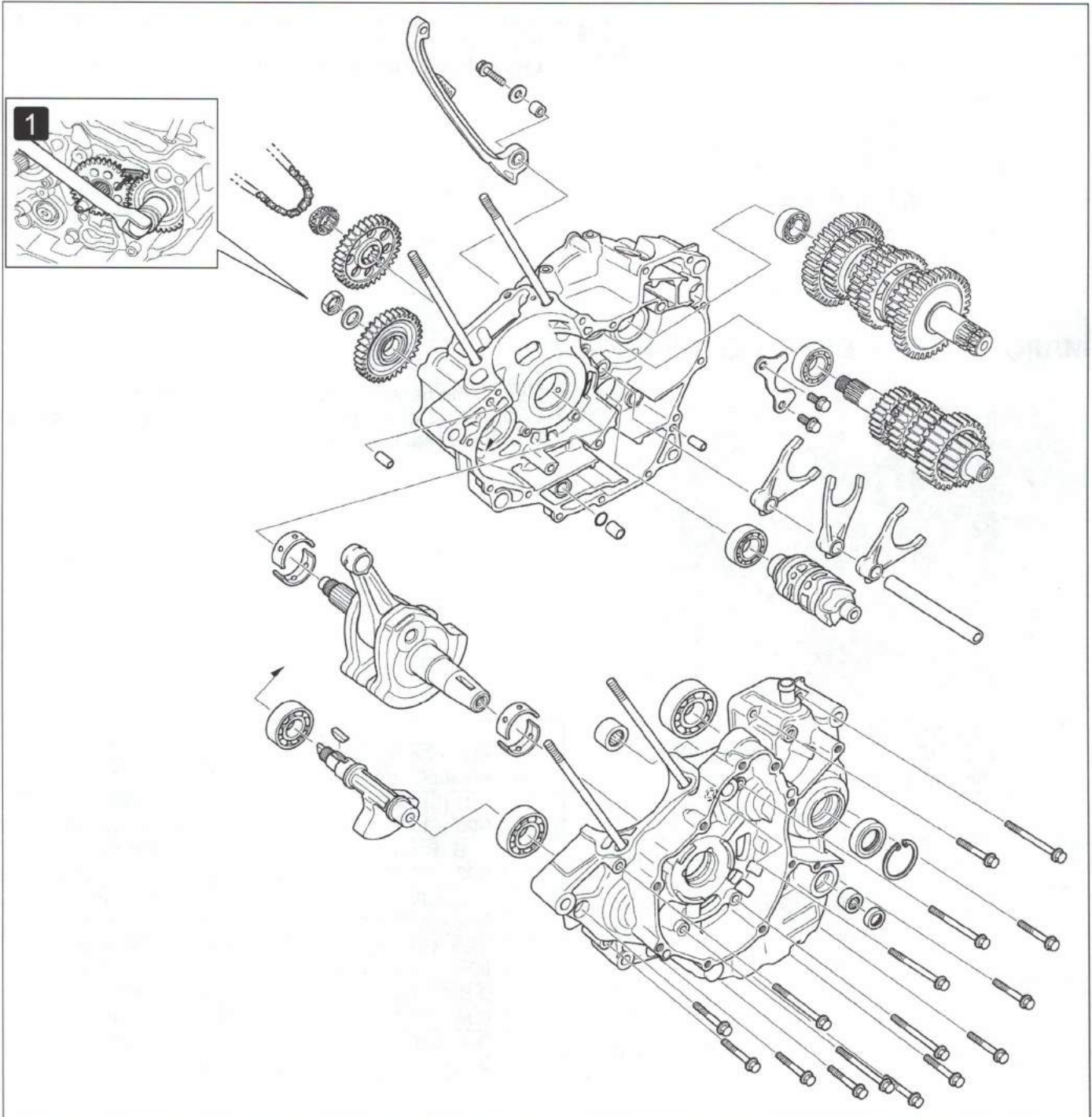

- Engine →2-40
- Cylinder/piston →2-29
- Clutch/gearshift linkage →2-30
- Alternator/starter clutch →2-33
- Oil pump →2-16
- VS sensor →4-61
- Gear position switch →4-33
- Starter motor →4-32
- **1** Insert the gear holder between the balancer drive gear and balancer driven gear assembly.
Gear holder, M2.5: 07724-0010100
- Remove the crankcase bolts in a crisscross pattern in 2 – 3 steps.
- Place the crankcase with the right crankcase facing down and separate.



CRANKSHAFT RUNOUT INSPECTION

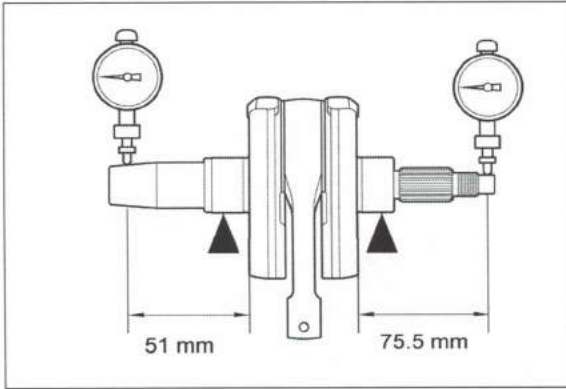

- Set the crankshaft on V-blocks and measure the runout using a dial indicator.
Limit: (L) 0.02 mm/(R) 0.03 mm

MAIN JOURNAL BEARING SELECTION



- Record the bearing support I.D. code letter [1].
- Letters A, B or C on each crankcase is the code for the crankcase main journal bearing support I.D.

BEARING SUPPORT I.D. CODE (Crankcase replaced)	BEARING SUPPORT I.D.	MAIN JOURNAL O.D.	
		33.985 – 34.000 mm (Crankshaft replaced)	33.975 – 33.985 mm
A	38.000 – 38.006 mm	C (Brown) 1.996 – 1.999 mm	B (Black) 1.999 – 2.002 mm
B	38.006 – 38.012 mm	B (Black) 1.999 – 2.002 mm	A (Blue) 2.002 – 2.005 mm
C	38.012 – 38.018 mm	A (Blue) 2.002 – 2.005 mm	O.S. G (Pink) 2.005 – 2.008 mm
-	38.018 – 38.024 mm	O.S. G (Pink) 2.005 – 2.008 mm	O.S. F (Yellow) 2.008 – 2.011 mm
-	38.024 – 38.030 mm	O.S. F (Yellow) 2.008 – 2.011 mm	O.S. E (Green) 2.011 – 2.014 mm
-	38.030 – 38.036 mm	O.S. E (Green) 2.011 – 2.014 mm	O.S. D (Red) 2.014 – 2.017 mm

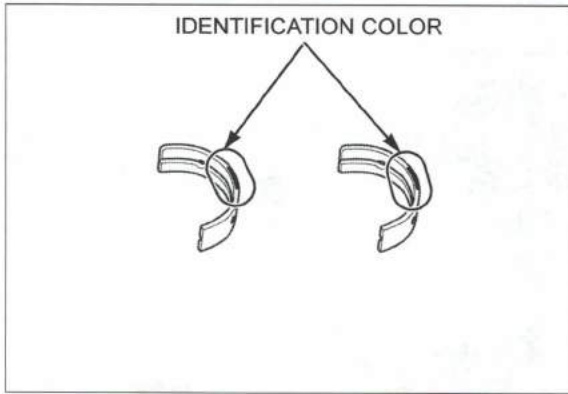

BEARING THICKNESS:

- | | |
|------------------|--------|
| O.S. D (Red): | Thick |
| O.S. E (Green): | ↑ |
| O.S. F (Yellow): | Middle |
| O.S. G (Pink): | ↓ |
| A (Blue): | |
| B (Black): | |
| C (Brown): | Thin |

- After selecting new bearings, recheck the clearance. Incorrect clearance can cause severe engine damage.

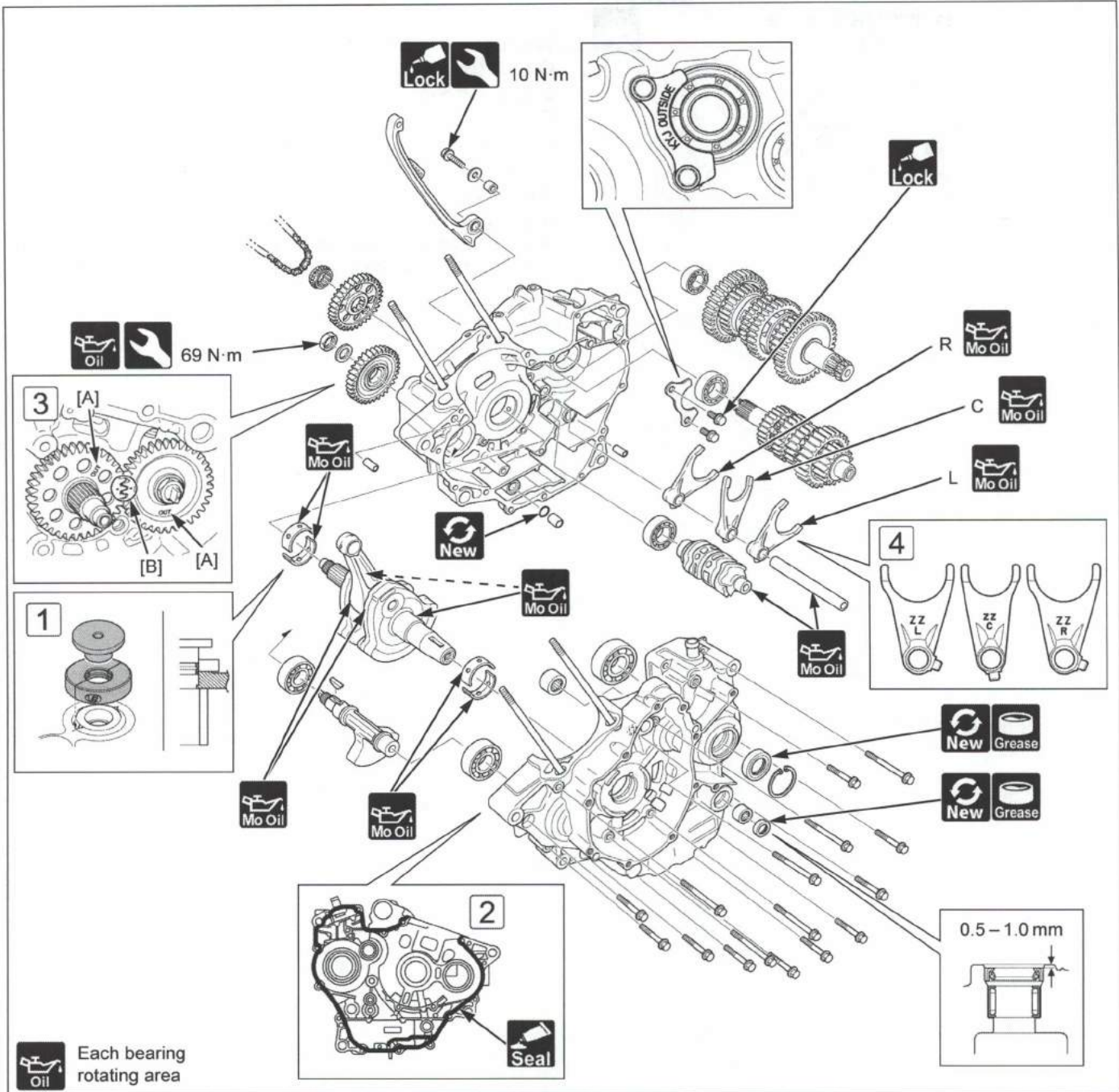

- [1] Set the bearings and special tools assembly on inside of the crankcase, fitting the bearing edge in the crankcase main journal. Align the mating line of the bearings with the index mark on the crankcase as shown. **Metal installer set: 070MF-KYJ0100**
- [2] Apply sealant (Three bond 1207B, 1215 or equivalent) to the left crankcase mating surface except the oil passage area.
- [3] Install the balancer drive and driven gear with its "OUT" mark [A] facing out. Align the punch marks [B] of the balancer drive and driven gear.
- [4] Each shift fork has an identification mark.
- Crankshaft inspection
- Connecting rod inspection
- Shift fork/shift drum/drum journal inspection





TRANSMISSION

MAINSHAFT

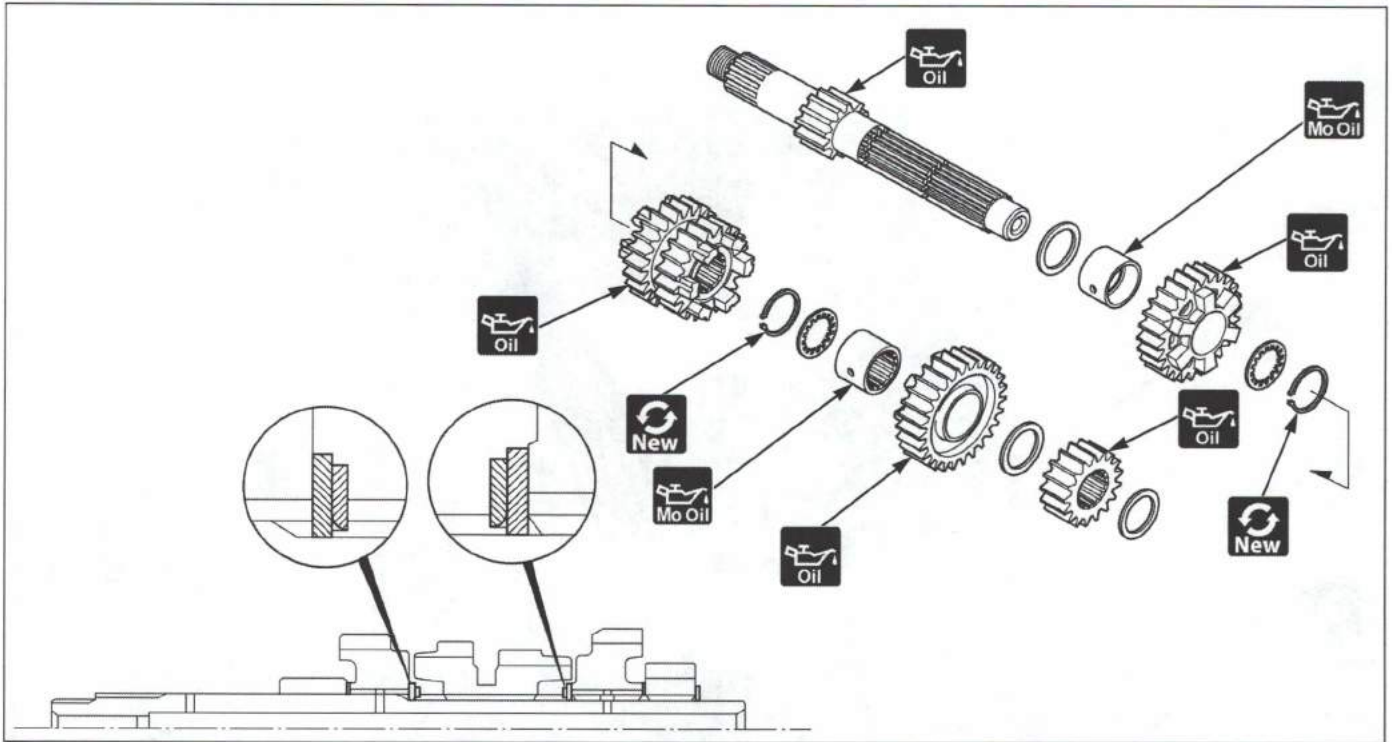

• Transmission inspection

COUNTERSHAFT

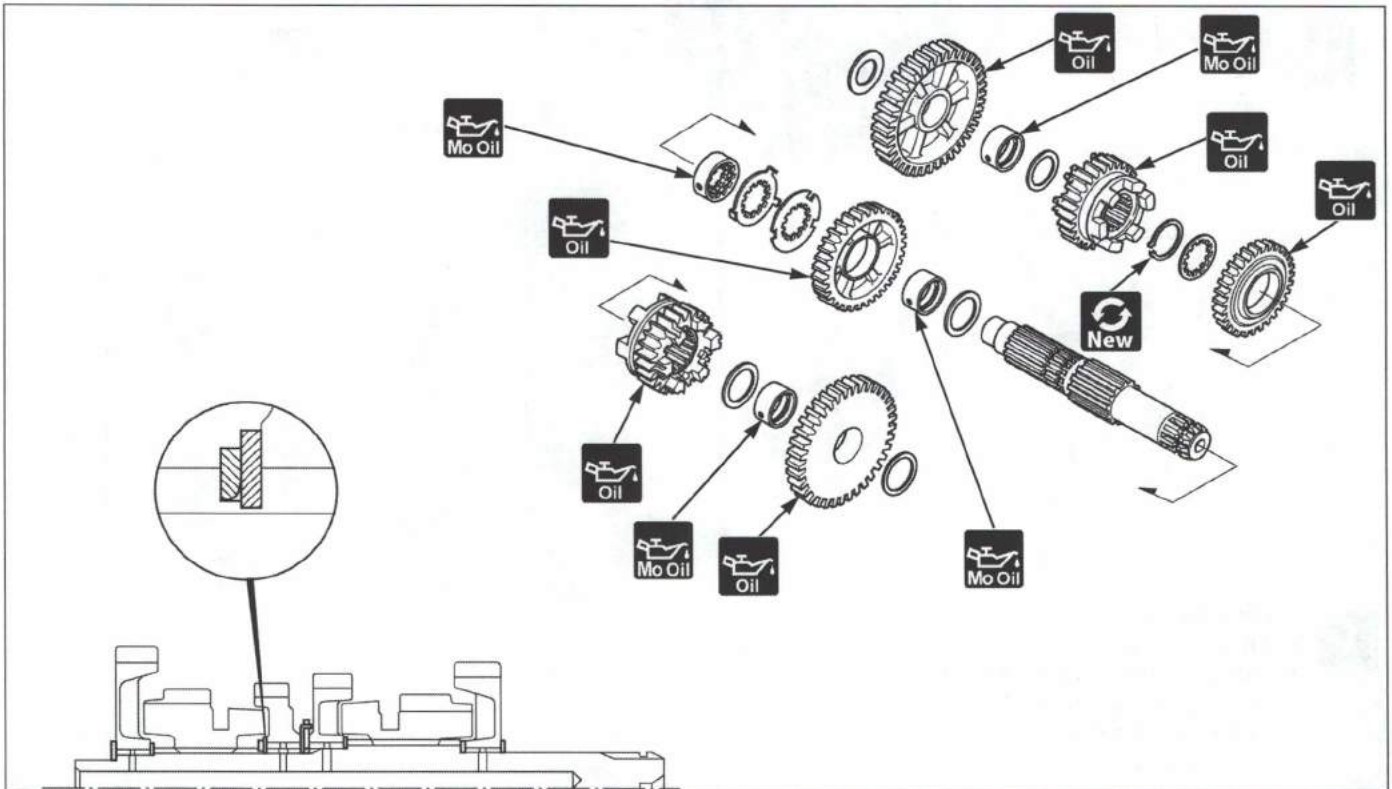

• Transmission inspection



ENGINE UNIT

Rally type

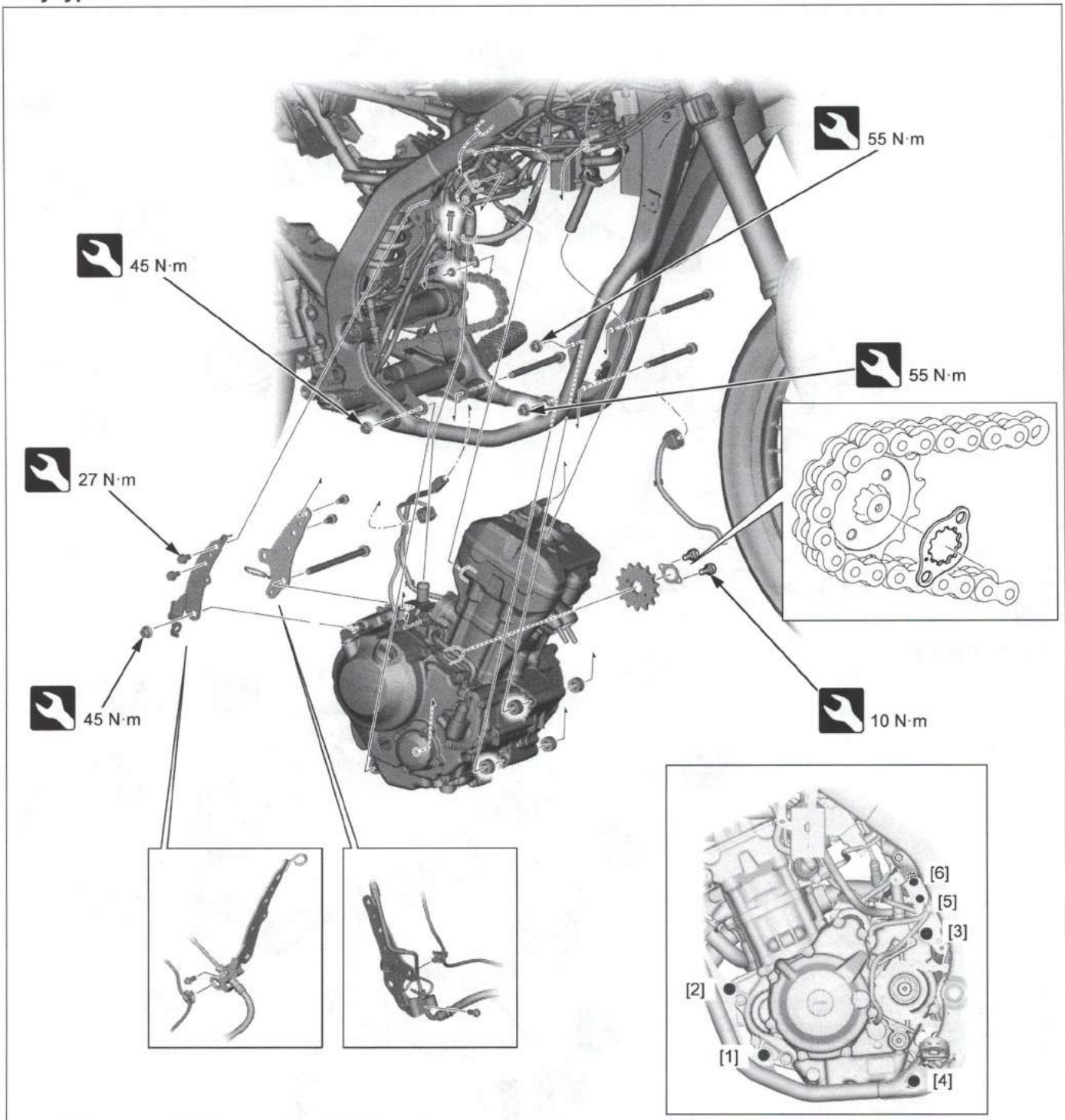

- Radiator →2-18
- Throttle body →2-8
- Exhaust pipe/muffler →3-24
- Drive sprocket cover →3-16
- Brake pedal →3-10
- EVAP system (AC type) →2-13



- [1] Loosely install all the engine fastener of [1] to [6], then tighten them with the specified torque in order of [1] to [6].



Standard type

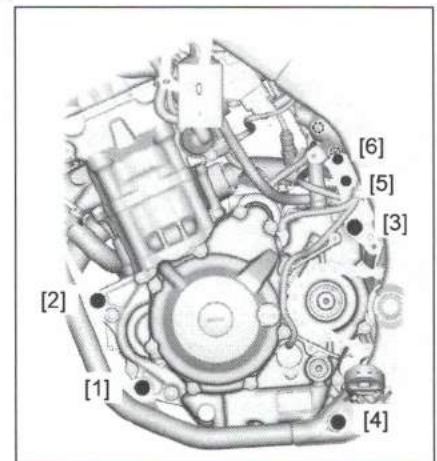
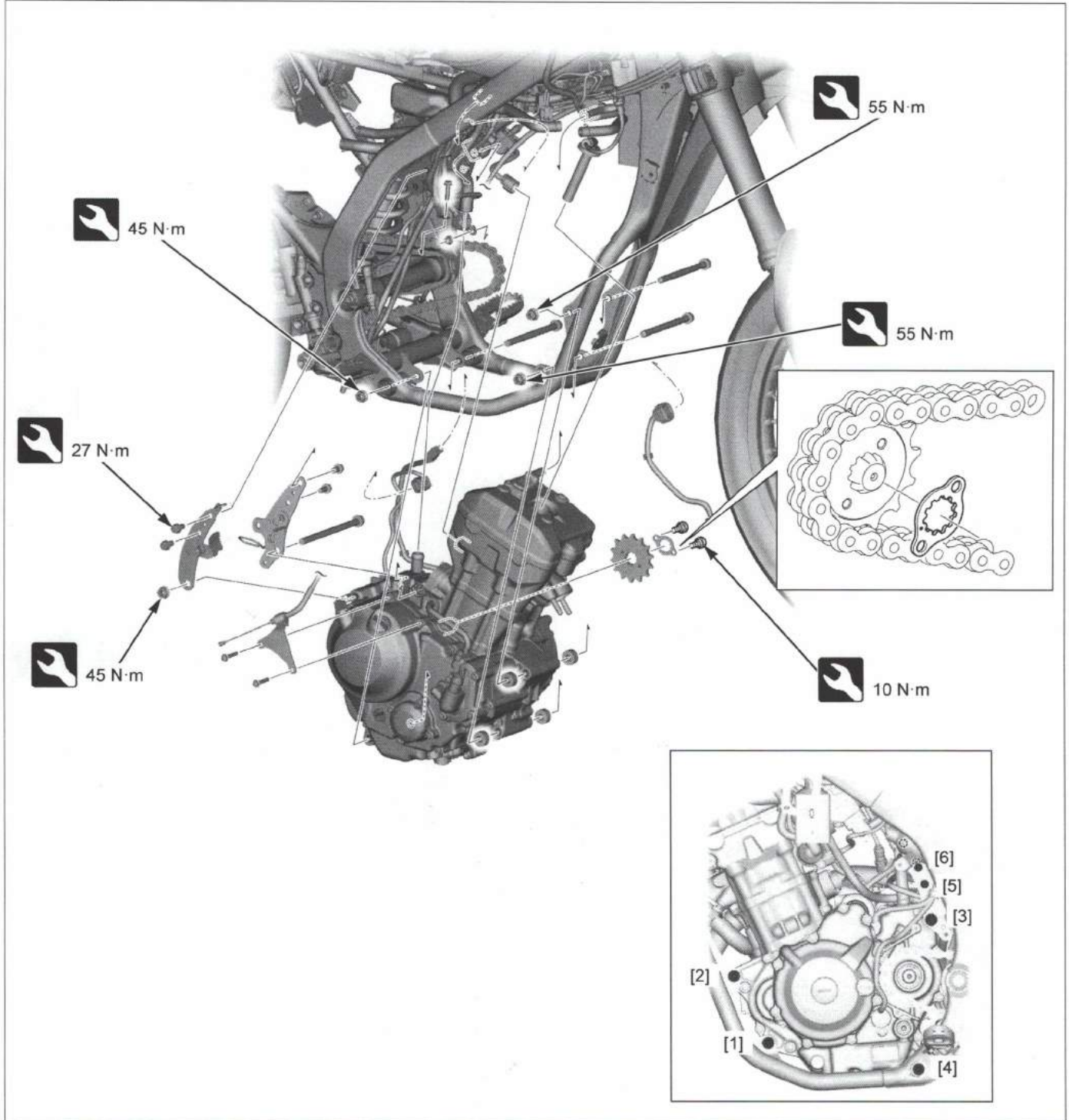

- Radiator →2-18
- Throttle body →2-8
- Exhaust pipe/muffler →3-24
- Drive sprocket cover →3-16
- Brake pedal →3-10
- EVAP system (AC type) →2-13



- [1] Loosely install all the engine fastener of [1] to [6], then tighten them with the specified torque in order of [1] to [6].

MEMO

3. FRAME & CHASSIS

BODY PANELS	3-2	STEERING STEM	3-32
SIDESTAND	3-23	REAR WHEEL	3-34
EXHAUST PIPE/MUFFLER	3-24	REAR SUSPENSION	3-36
FRONT WHEEL	3-26	FRONT BRAKE	3-37
FORK	3-28	REAR BRAKE	3-40
HANDLEBAR	3-31		

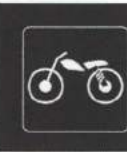



BODY PANELS

Rally type

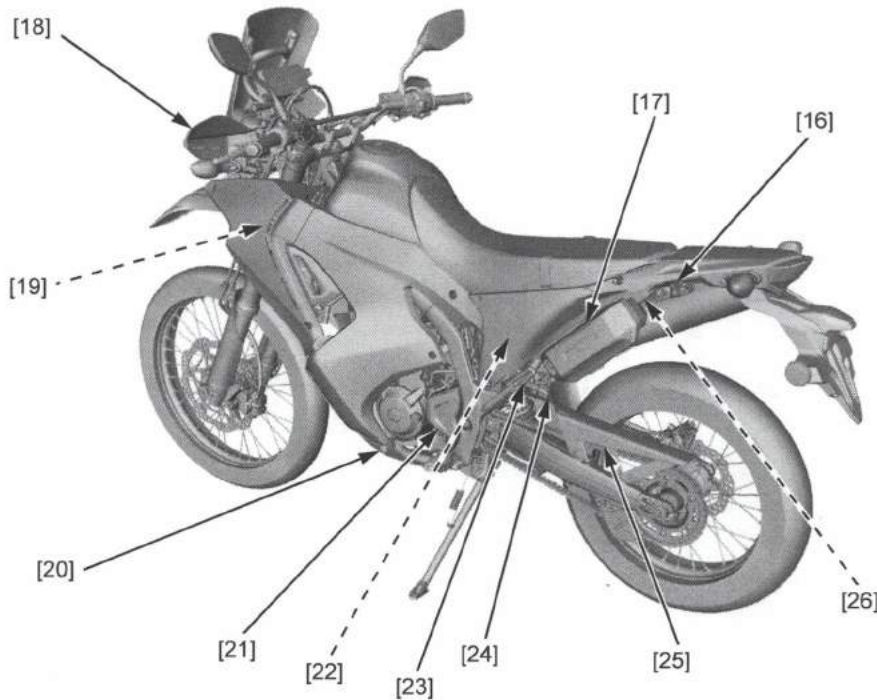
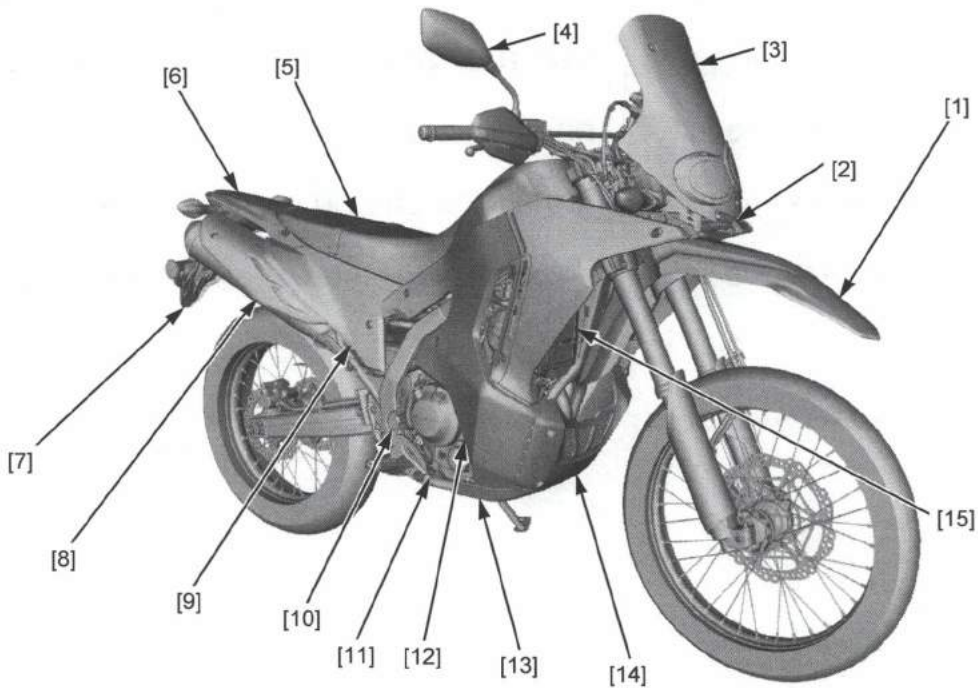

- [1] Front fender → 3-4
- [2] Turn signal light stay → 3-6
- [3] Windscreen → 3-5
- [4] Rearview mirror → 3-4
- [5] Seat → 3-5
- [6] Rear fender → 3-8
- [7] Number plate bracket → 3-9
- [8] Muffler guard → 3-20
- [9] Side cover → 3-8

- [10] Heel guard → 3-18
- [11] Brake pedal → 3-10
- [12] Fuel tank shroud → 3-13
- [13] Front under cowl → 3-7
- [14] Front under guard → 3-7
- [15] Radiator guard → 3-20
- [16] Helmet holder → 3-19
- [17] Tool box → 3-21
- [18] Knuckle guard → 3-11

- [19] Reserve tank cover → 3-12
- [20] Gearshift pedal → 3-16
- [21] Drive sprocket cover → 3-16
- [22] Battery box → 3-22
- [23] Pillion step → 3-10
- [24] Mud guard → 3-18
- [25] Chain case → 3-19
- [26] Rear fender B → 3-17



Standard type

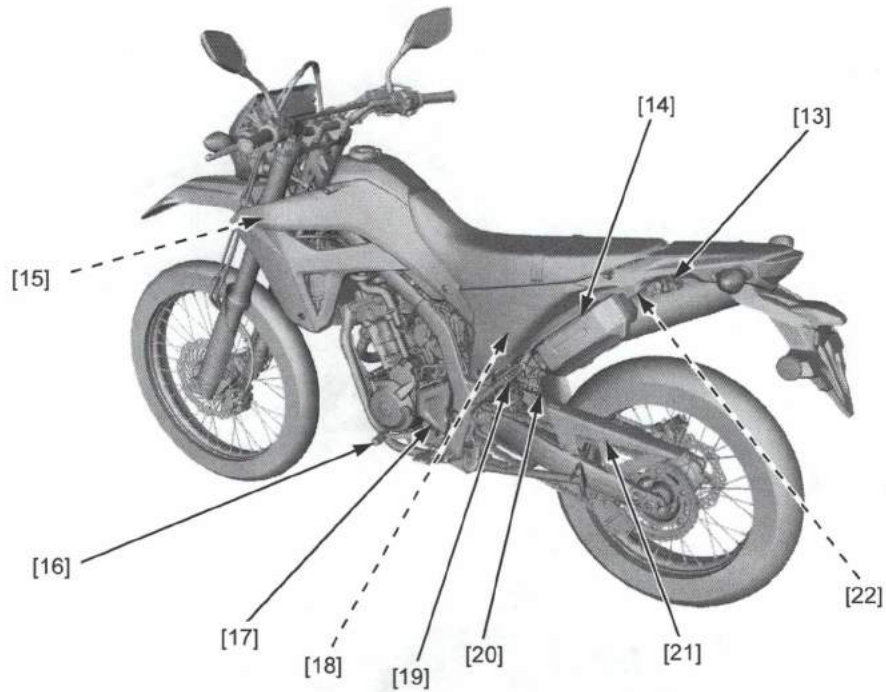

- [1] Front fender →3-4
- [2] Front visor →3-6
- [3] Rearview mirror →3-4
- [4] Seat →3-5
- [5] Rear fender →3-8
- [6] Number plate bracket →3-9
- [7] Muffler guard →3-20
- [8] Side cover →3-8
- [9] Heel guard →3-18

- [10] Brake pedal →3-10
- [11] Fuel tank shroud →3-13
- [12] Radiator guard →3-20
- [13] Helmet holder →3-19
- [14] Tool box →3-21
- [15] Reserve tank cover →3-12
- [16] Gearshift pedal →3-16
- [17] Drive sprocket cover →3-16
- [18] Battery box →3-22

- [19] Pillion step →3-10
- [20] Mud guard →3-18
- [21] Chain case →3-19
- [22] Rear fender B →3-17



FRONT FENDER

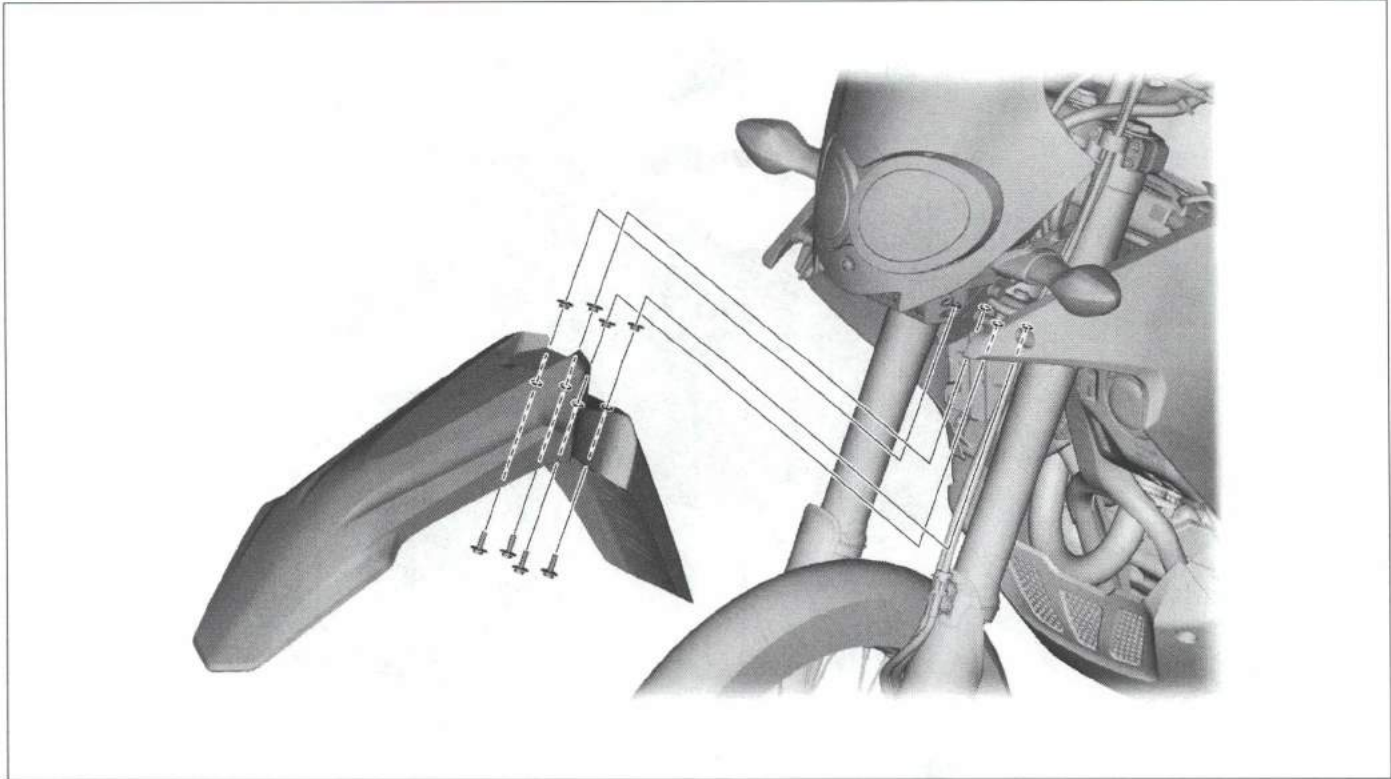

REARVIEW MIRROR

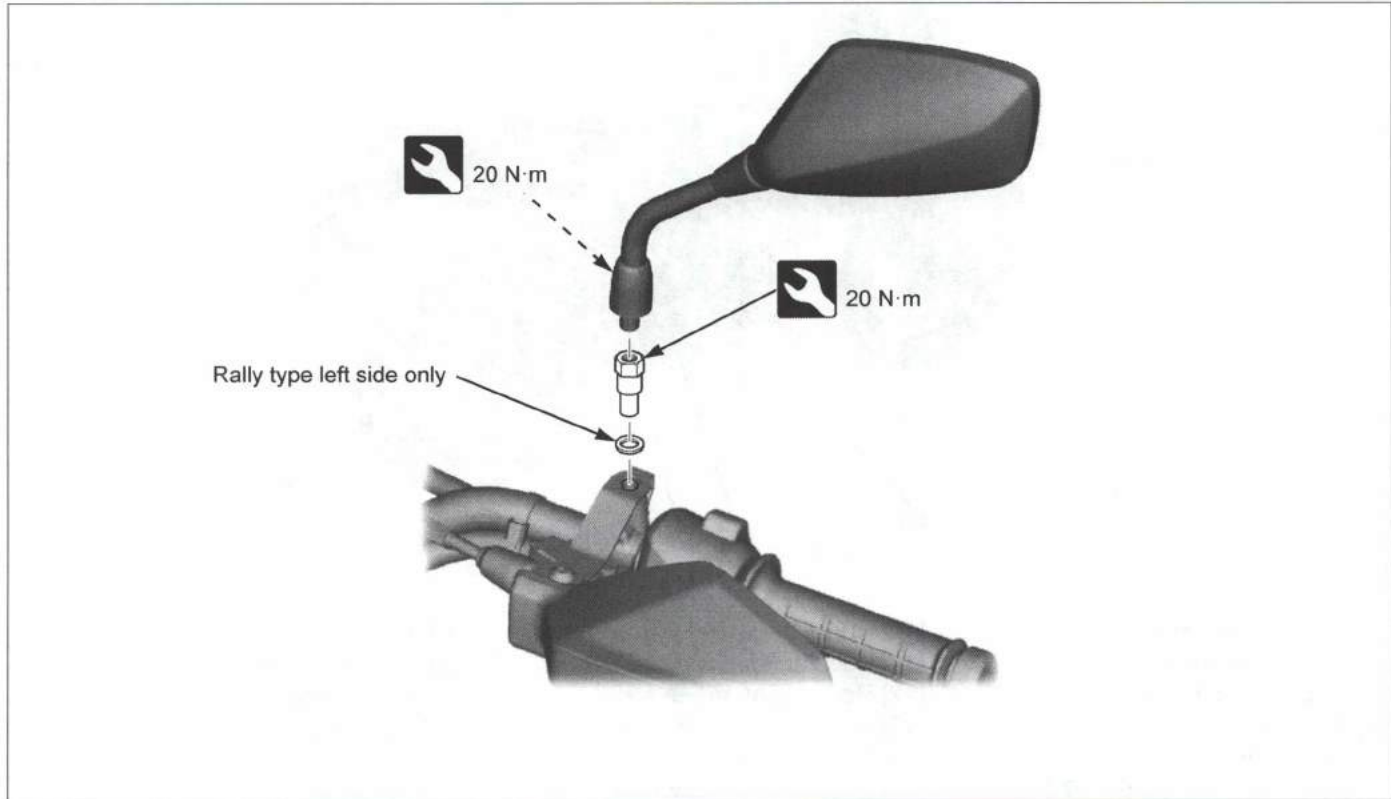



SEAT

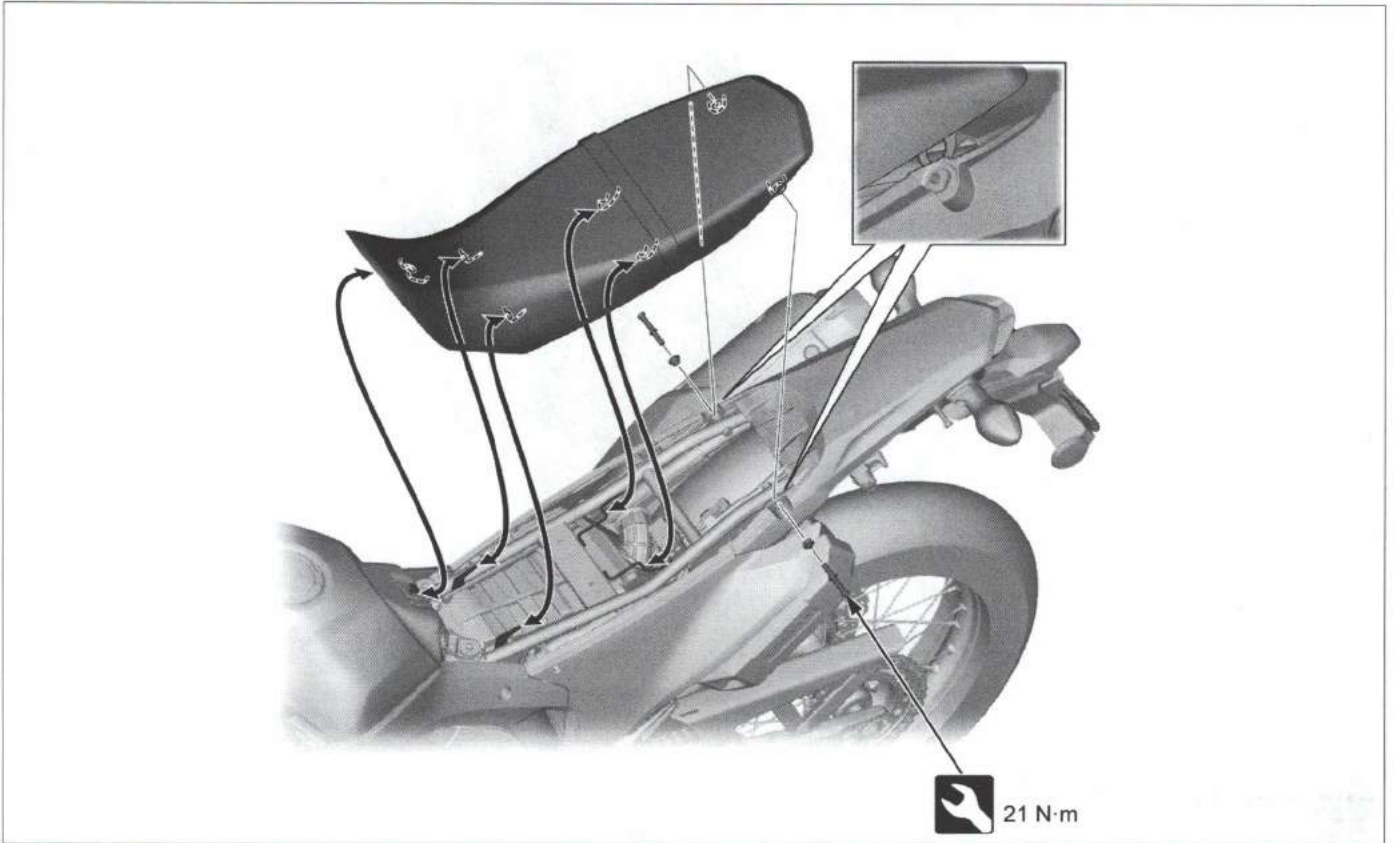

WINDSCREEN (Rally type)

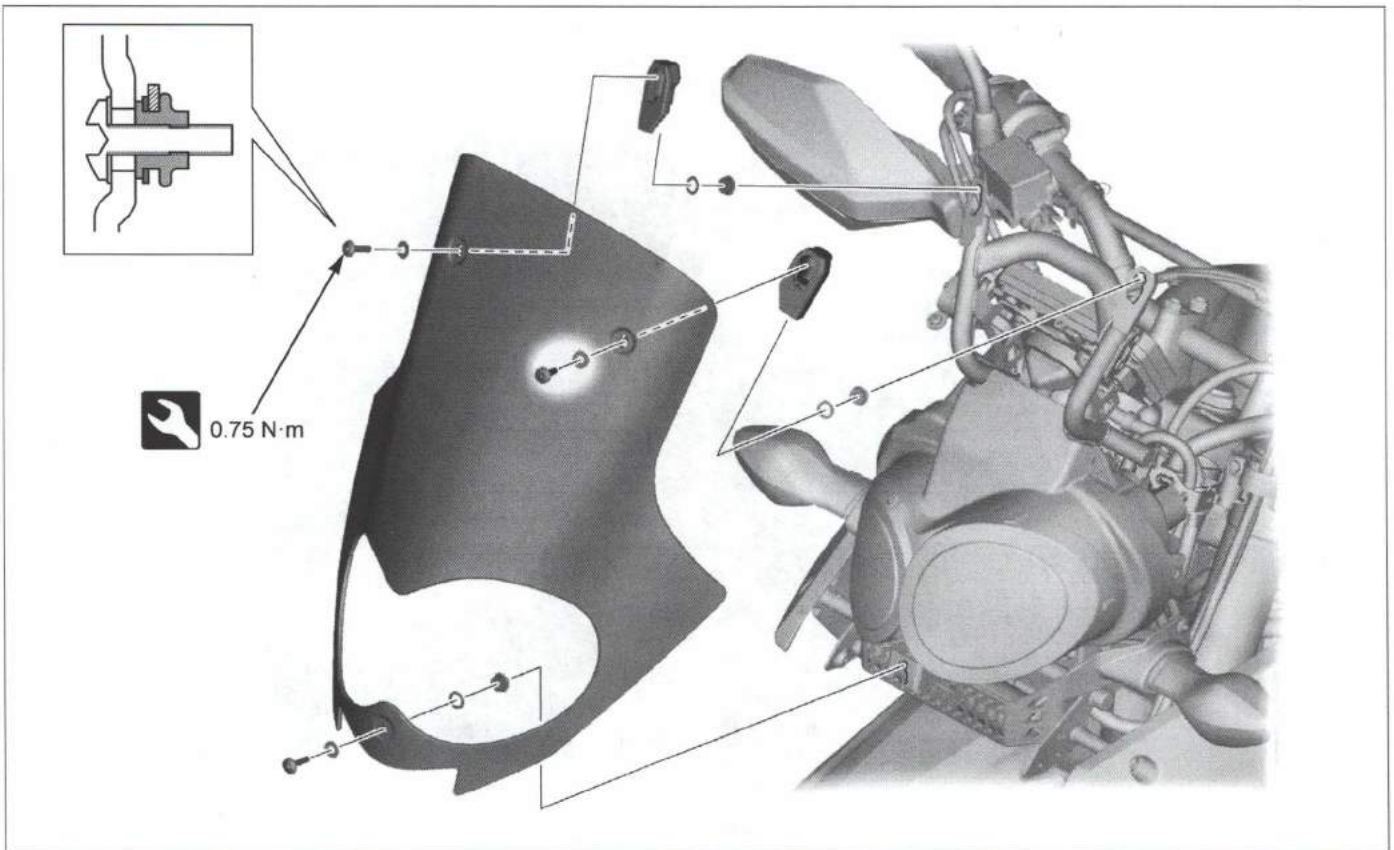



TURN SIGNAL LIGHT STAY

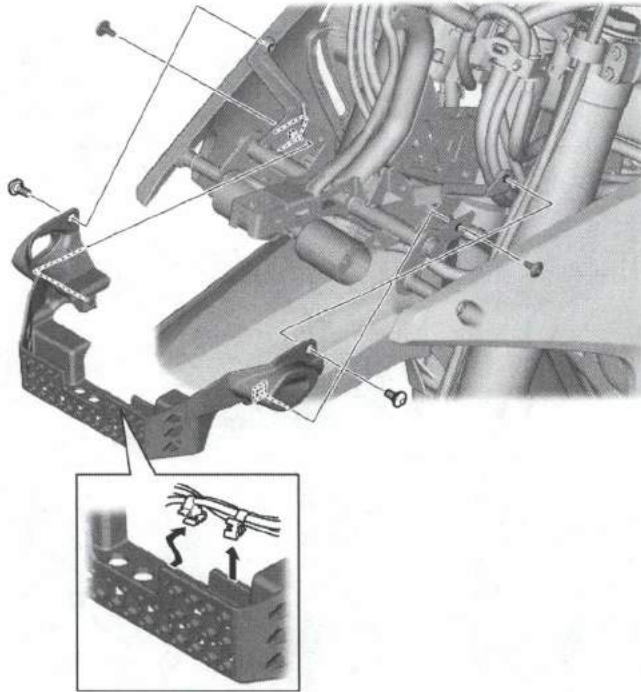

- Front turn signal light →4-52

FRONT VISOR (Standard type)

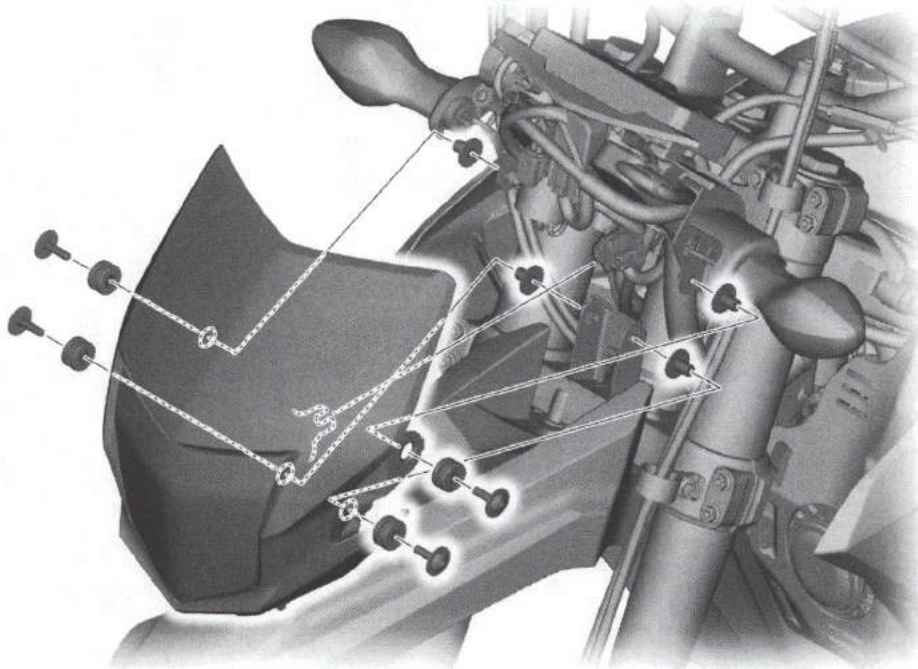



FRONT UNDER GUARD (Rally type)

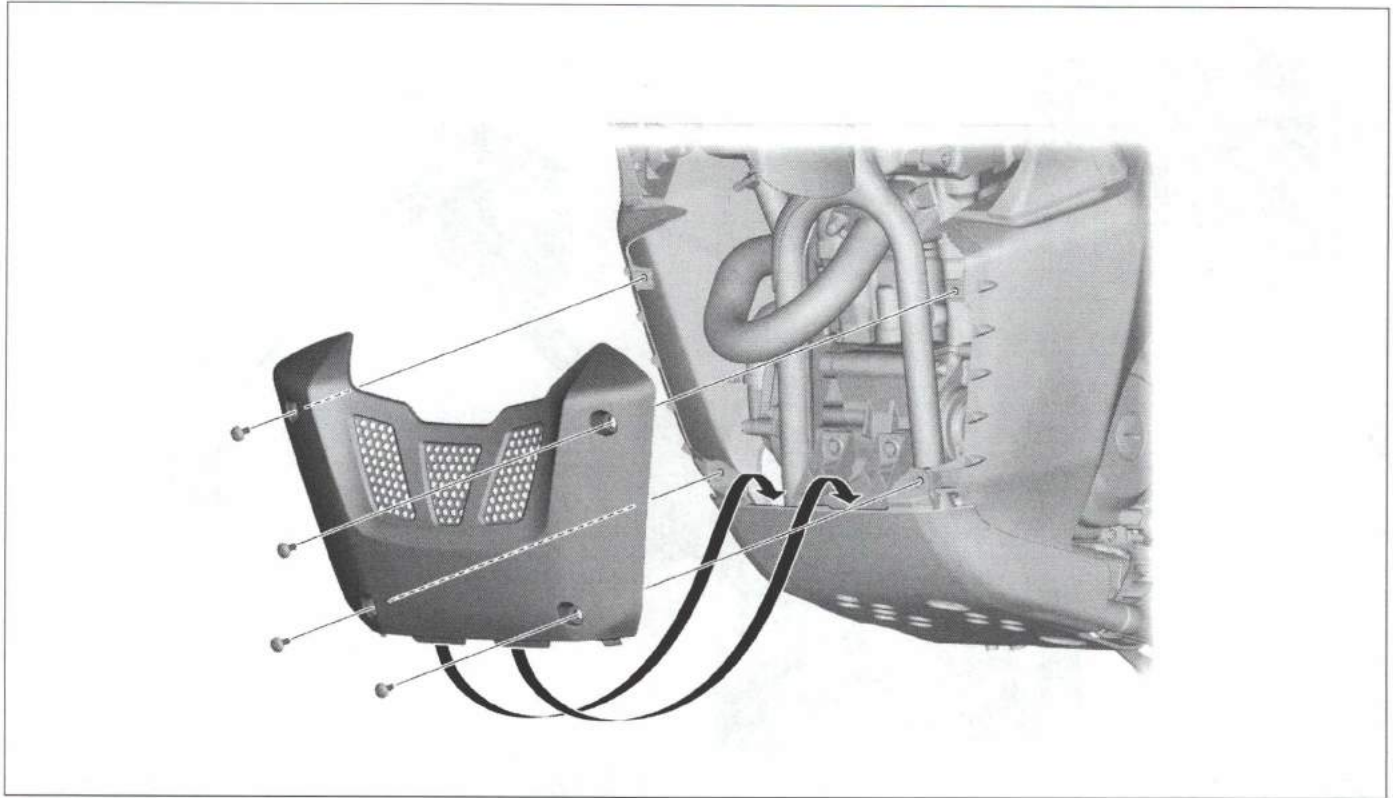

REAR UNDER COWL (Rally type)

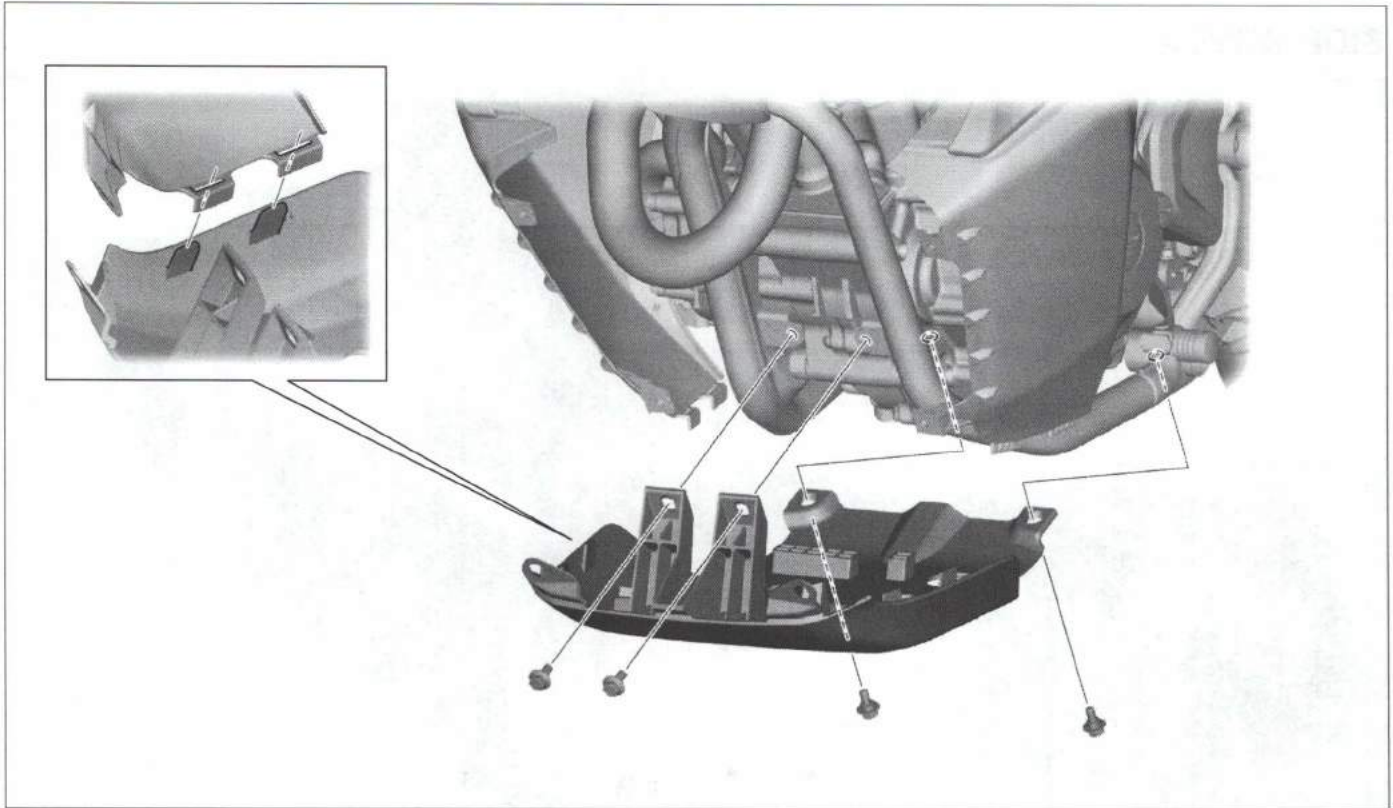

• Front under guard →3-7



REAR FENDER

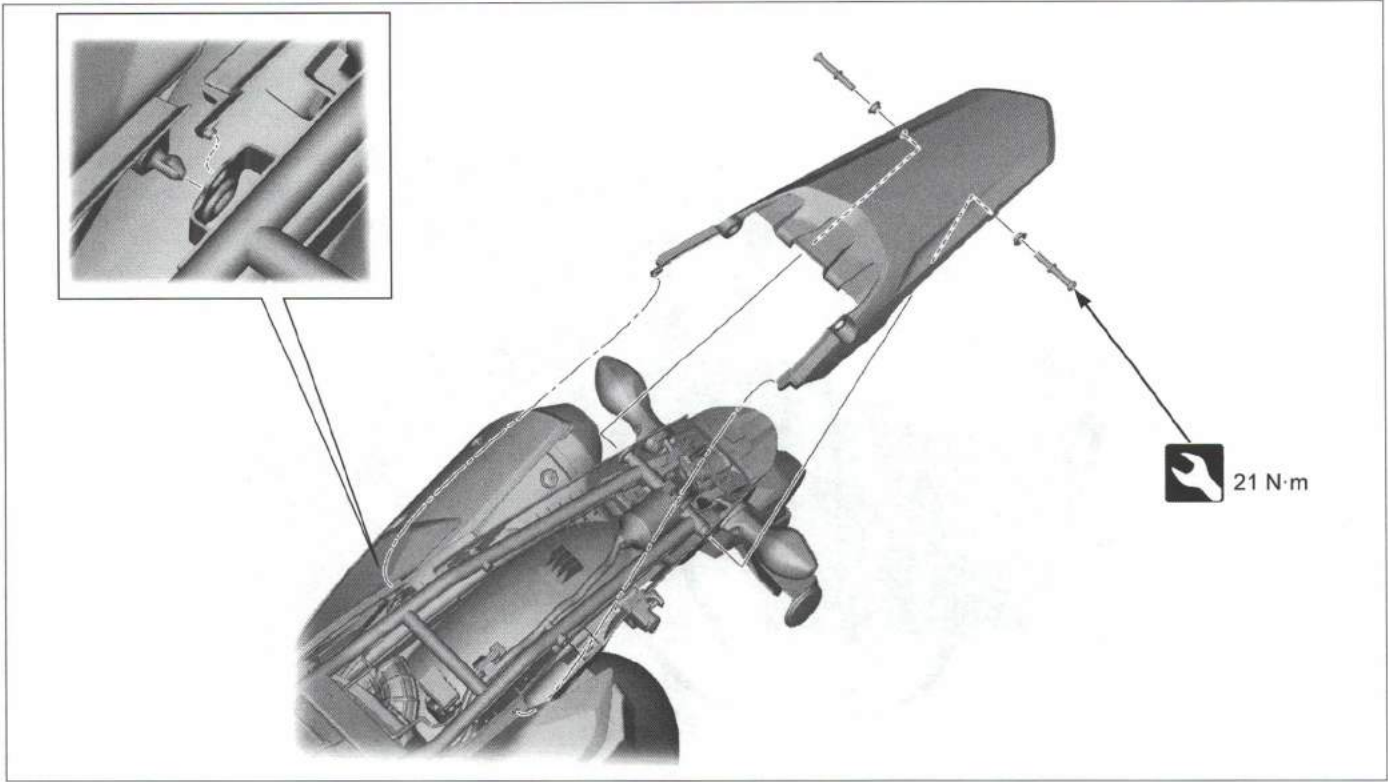

• Seat →3-5

SIDE COVER

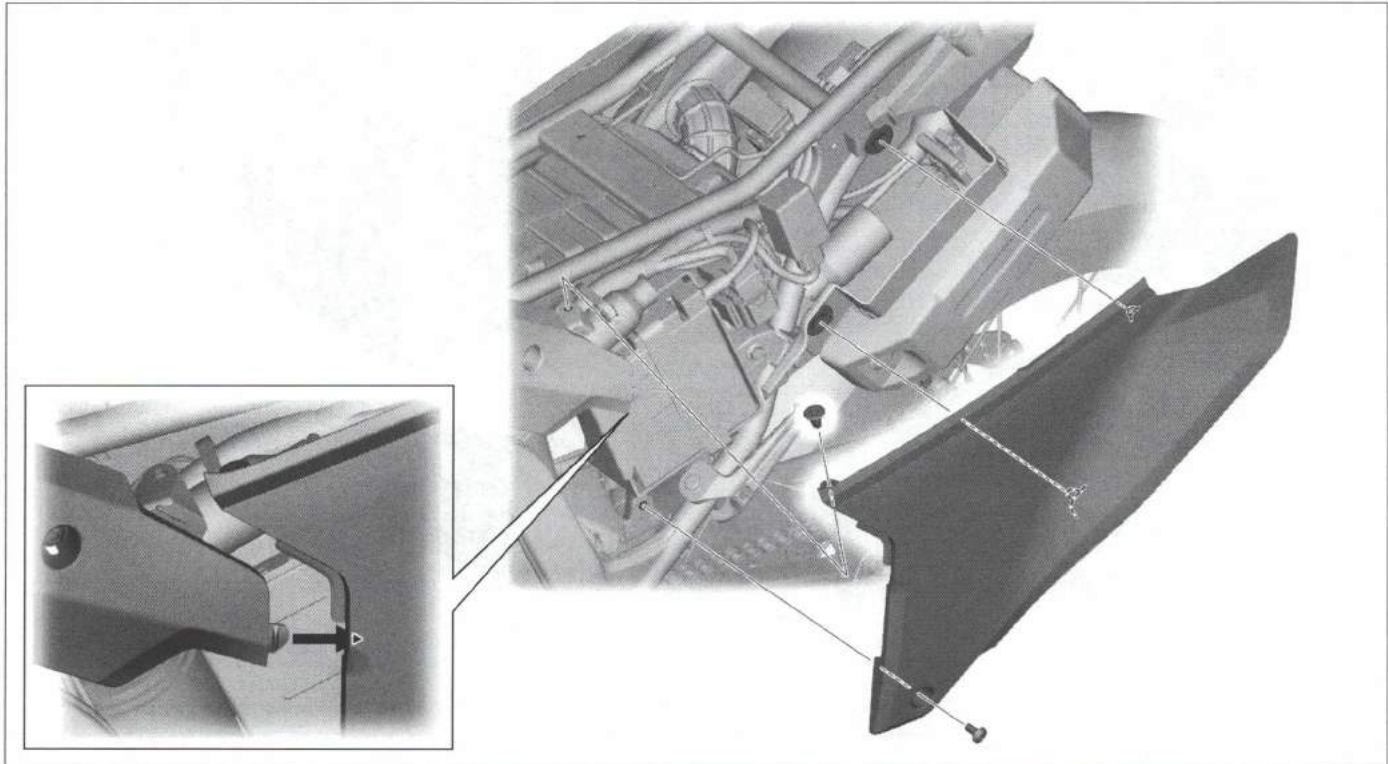

• Seat →3-5



NUMBER PLATE BRACKET

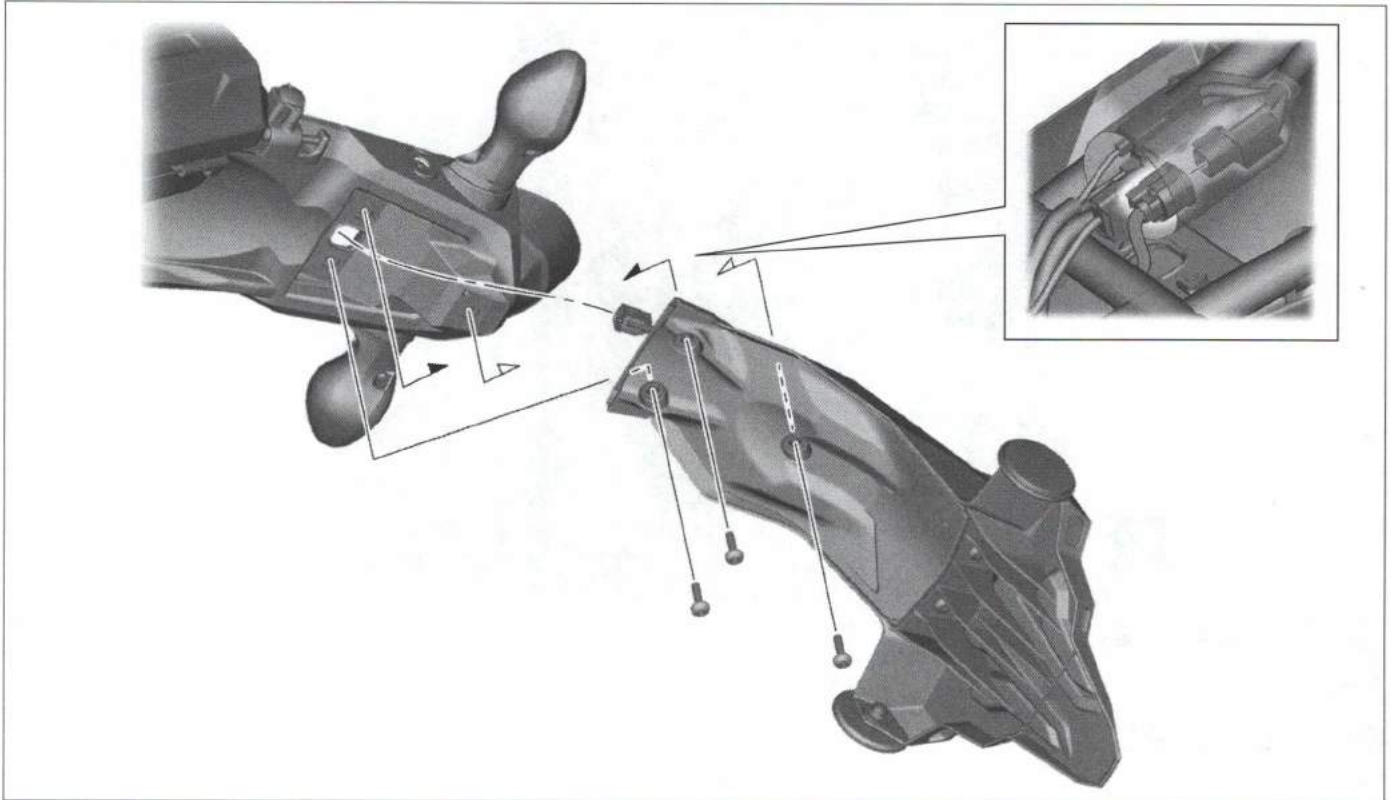

• Rear fender → 3-8

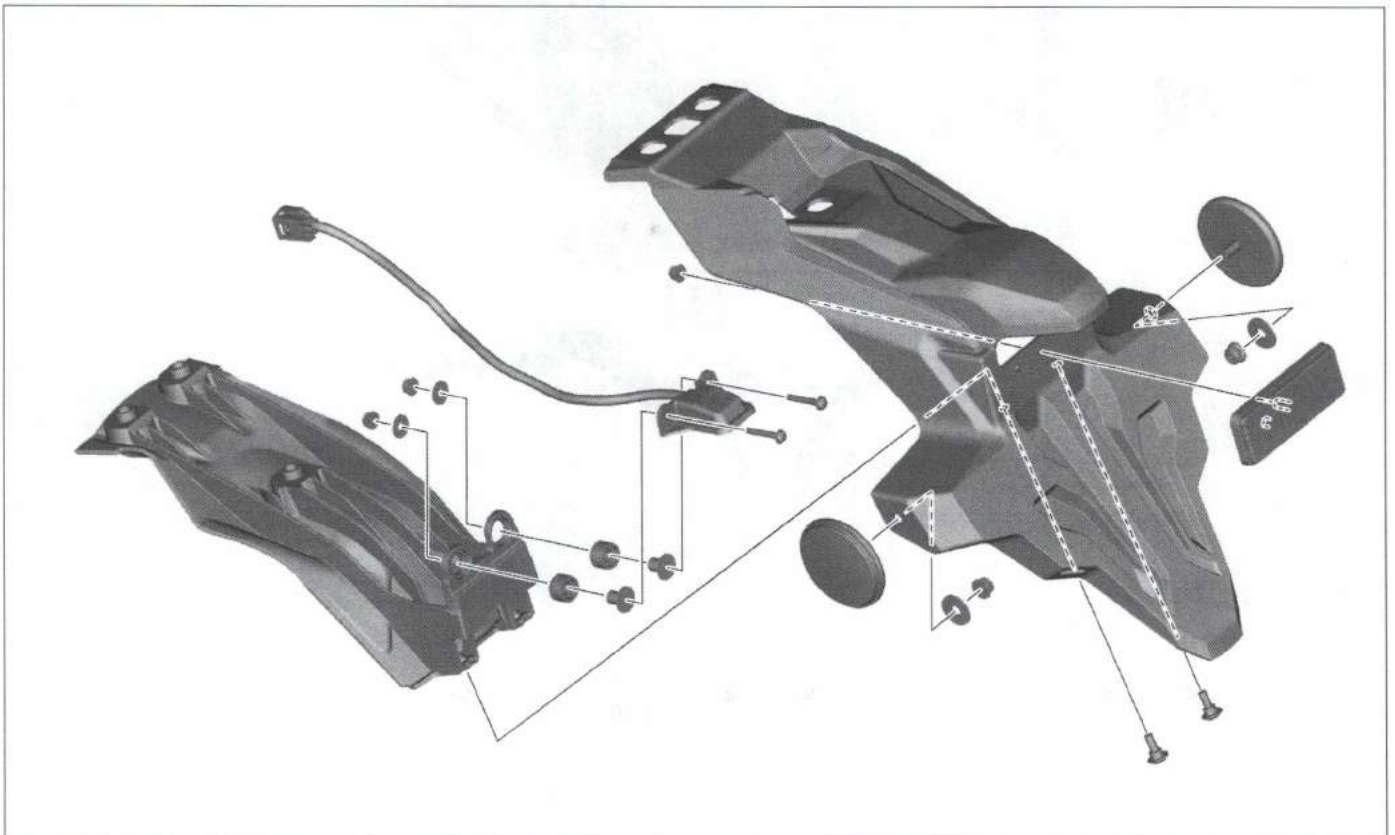



PILLION STEP

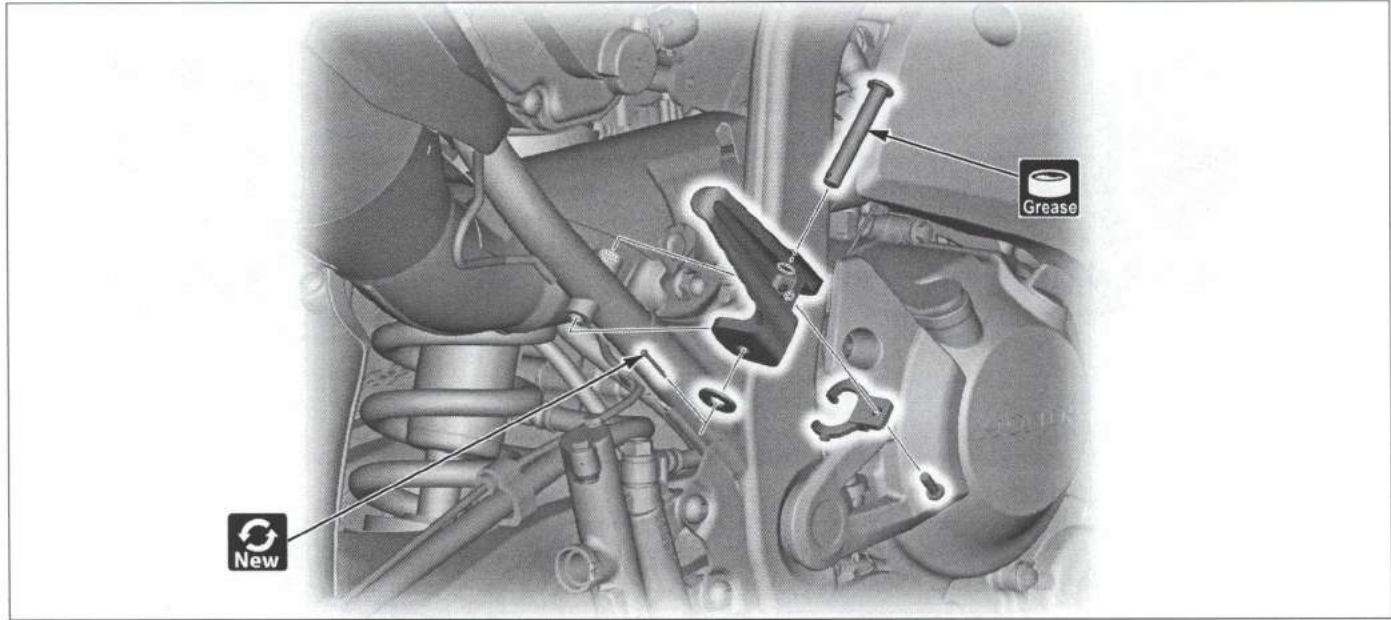

• Side cover →3-8

BRAKE PEDAL

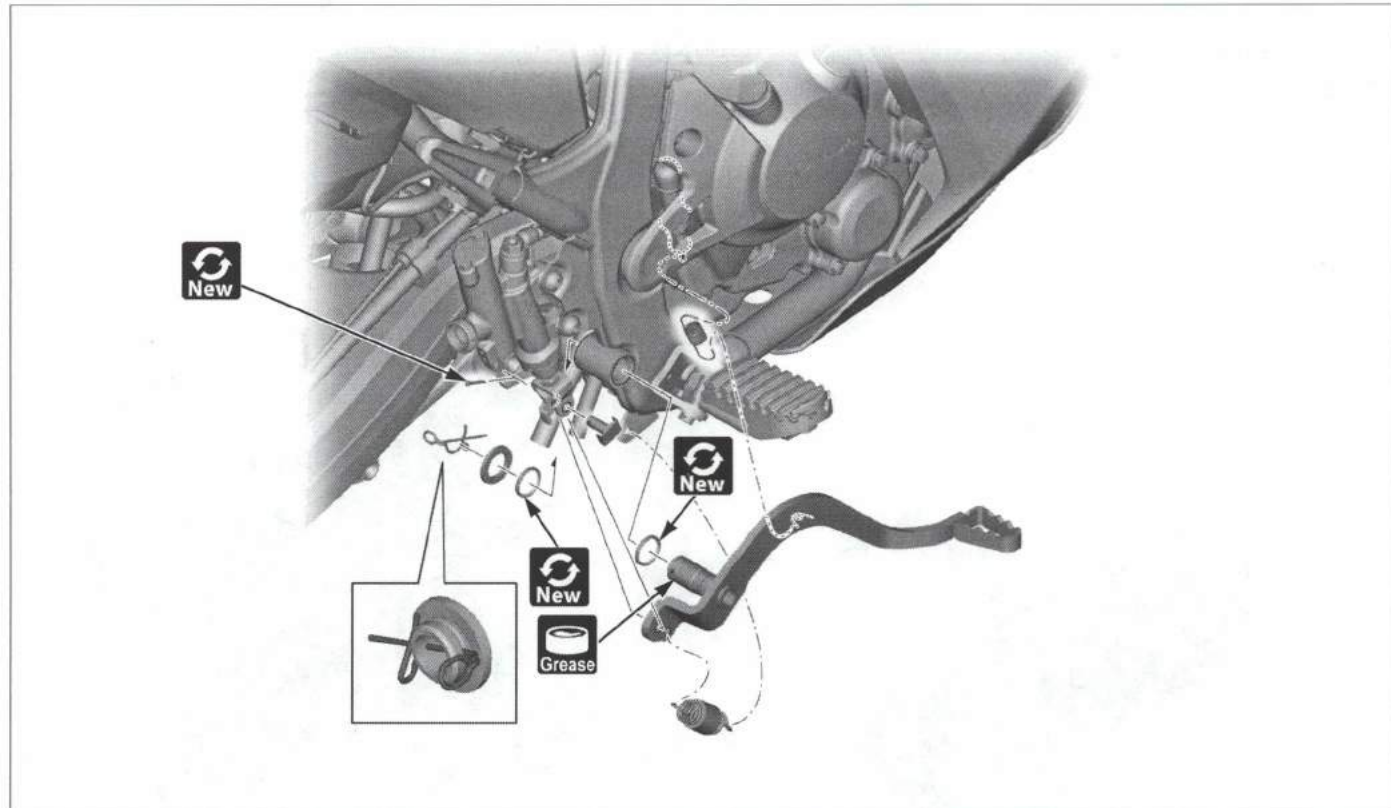



KNUCKLE GUARD (Rally type only)/BRAKE LEVER

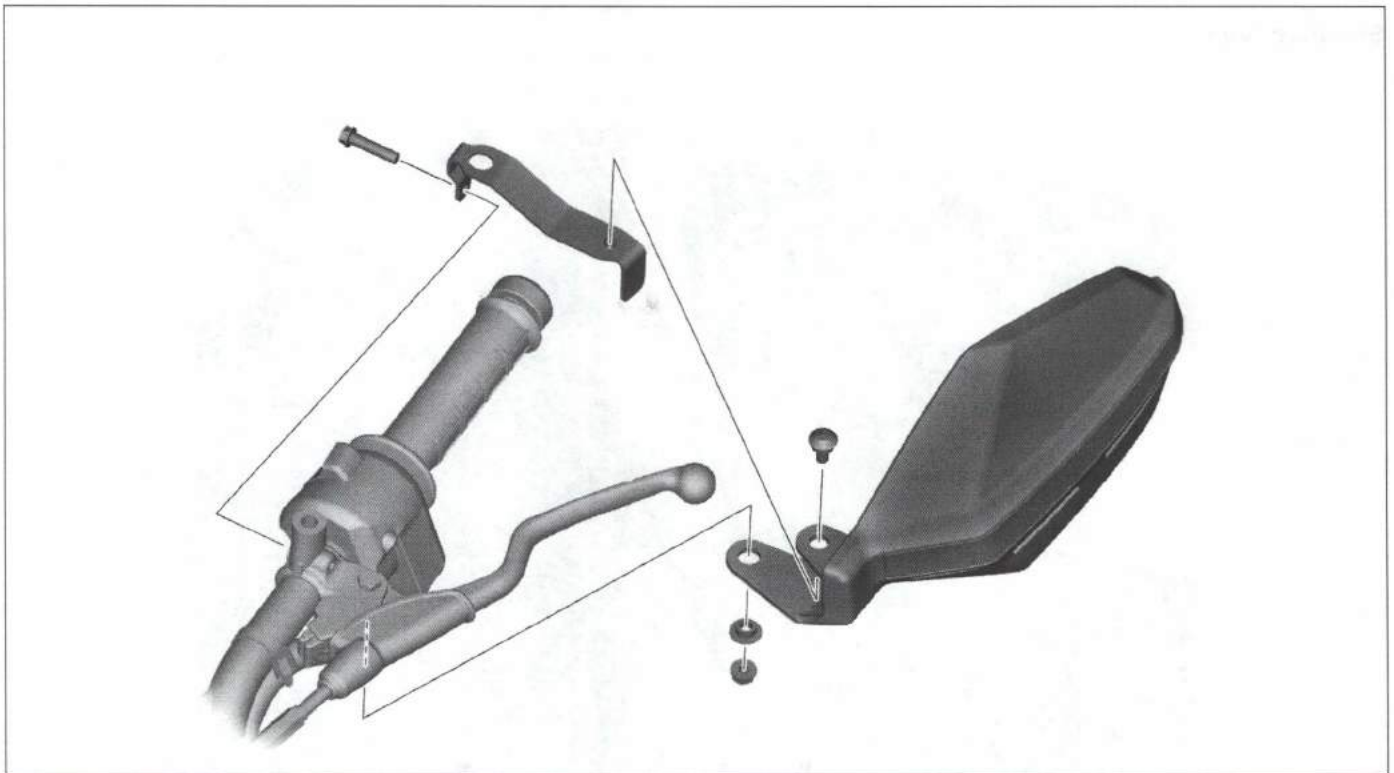
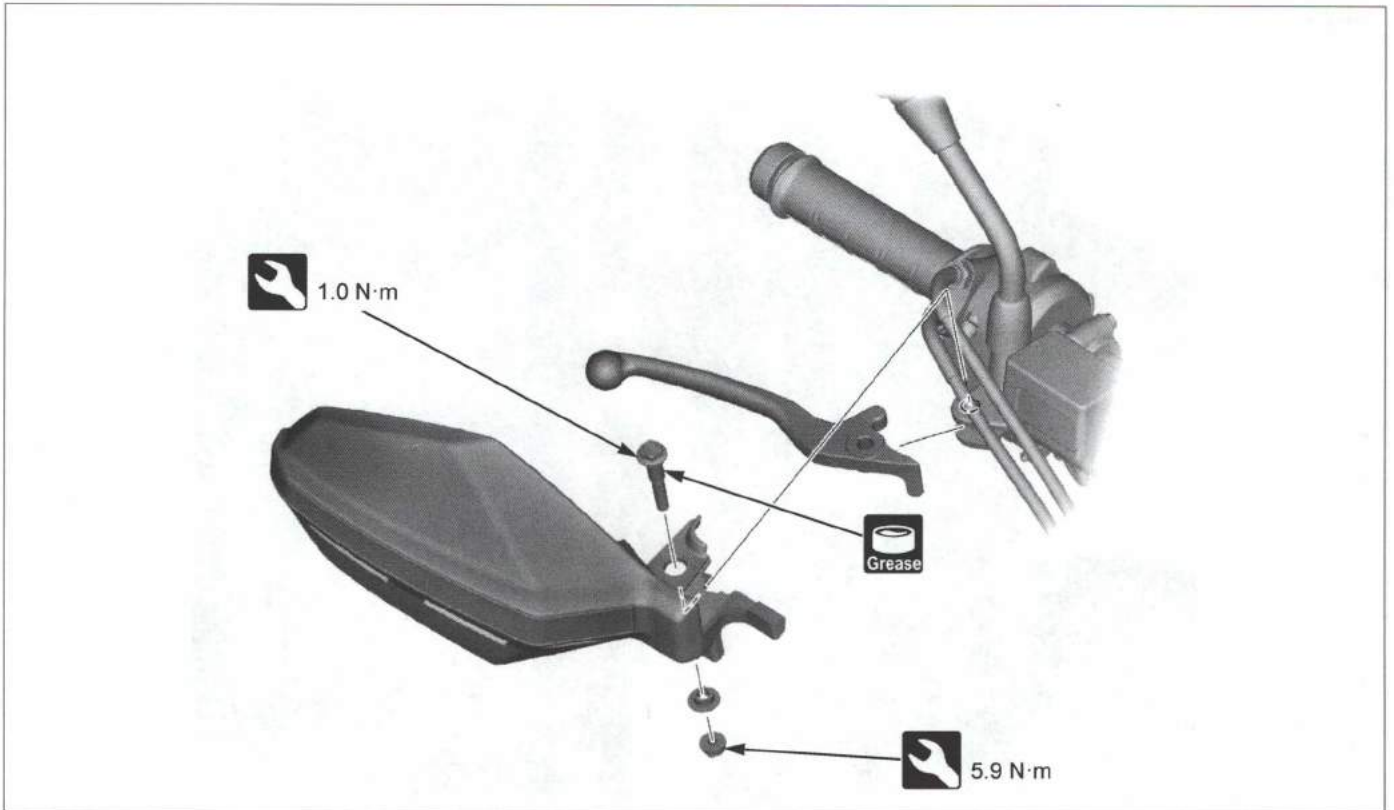

• Rearview mirror →3-4



RESERVE TANK COVER

Rally type

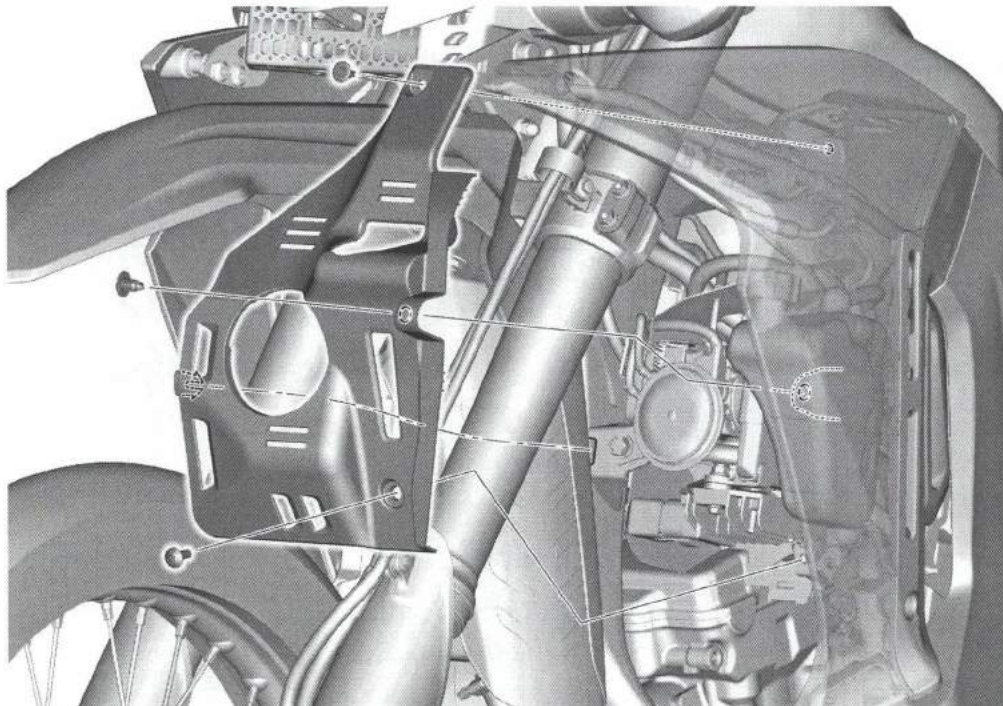

Standard type

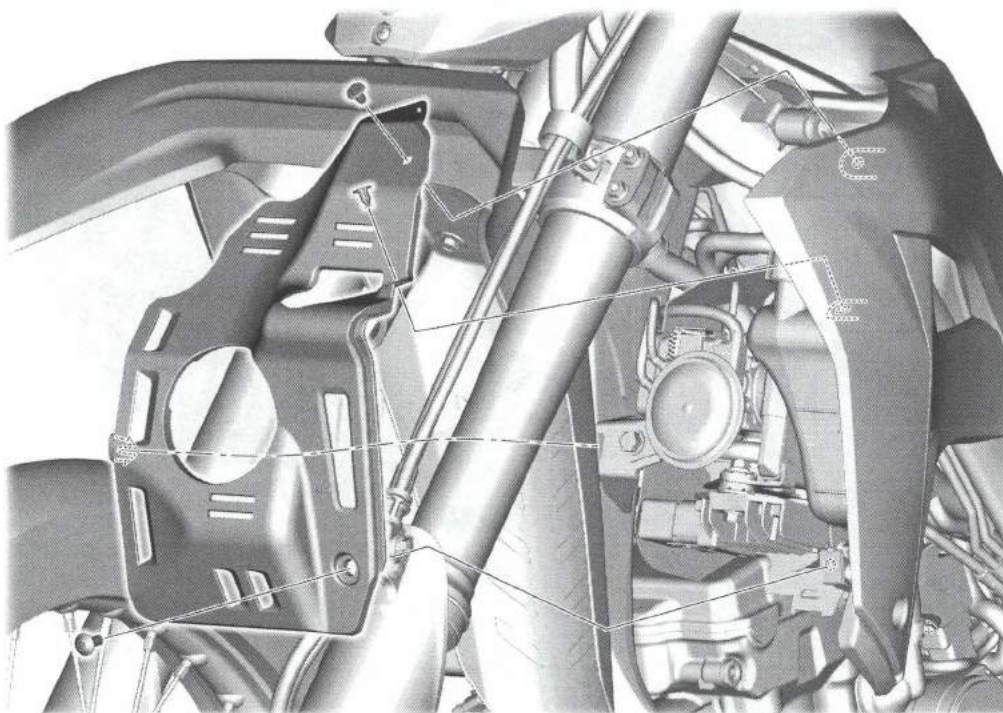



FUEL TANK SHROUD

Rally type right

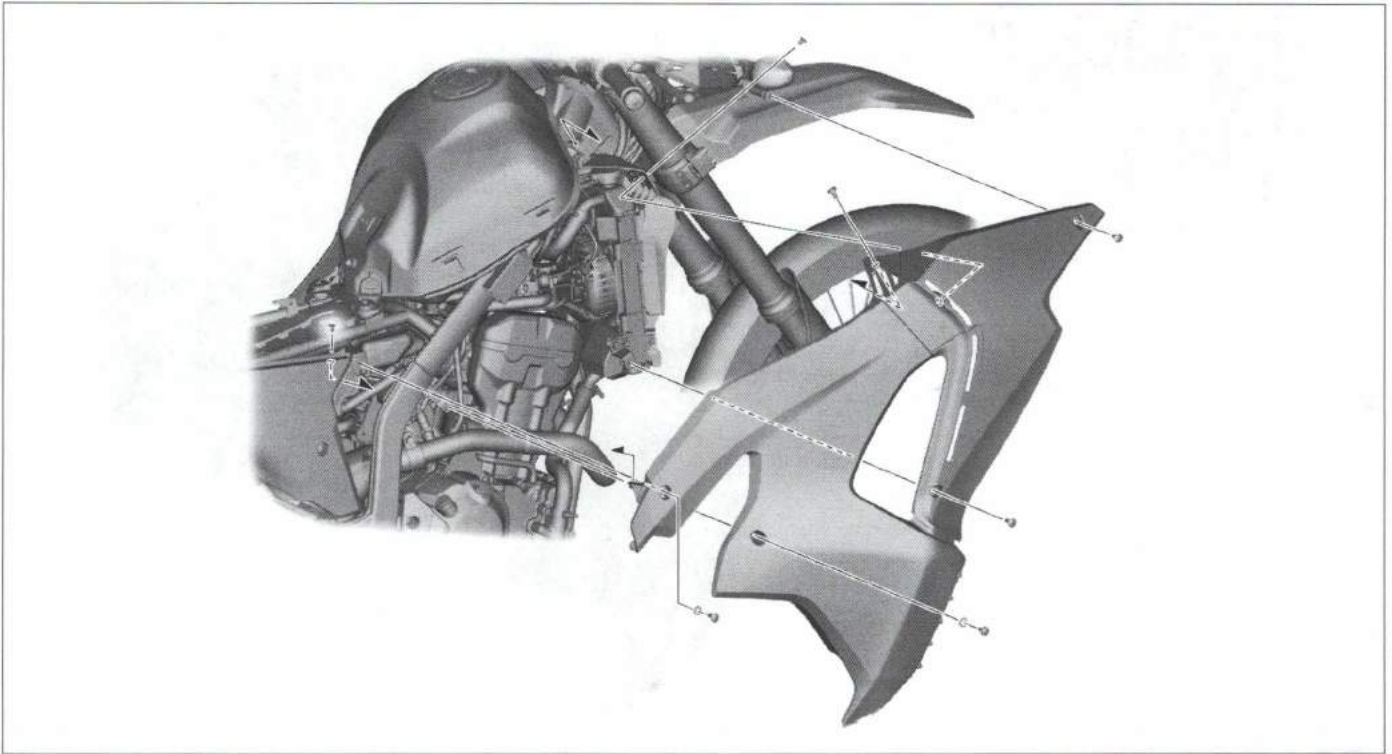

- Seat →3-5
- Front under guard →3-7

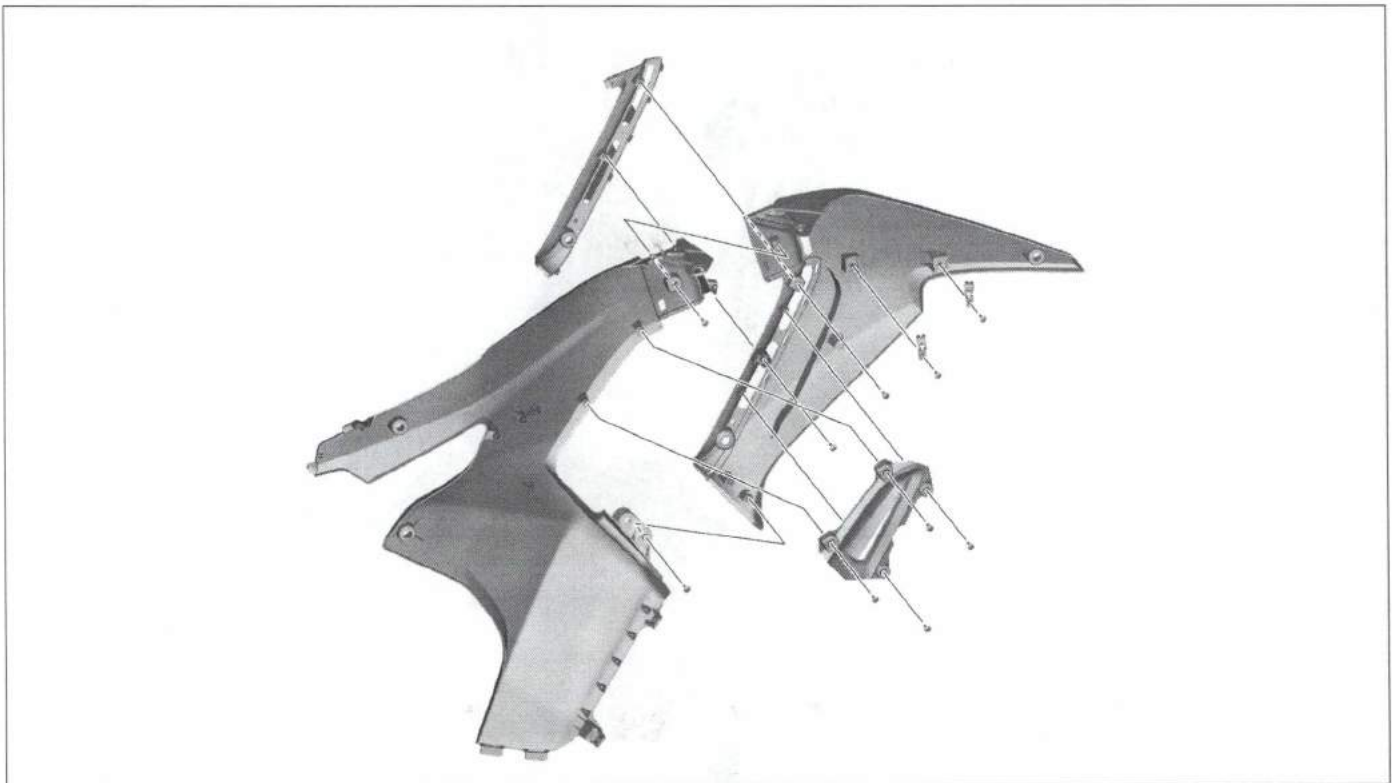



Rally type left

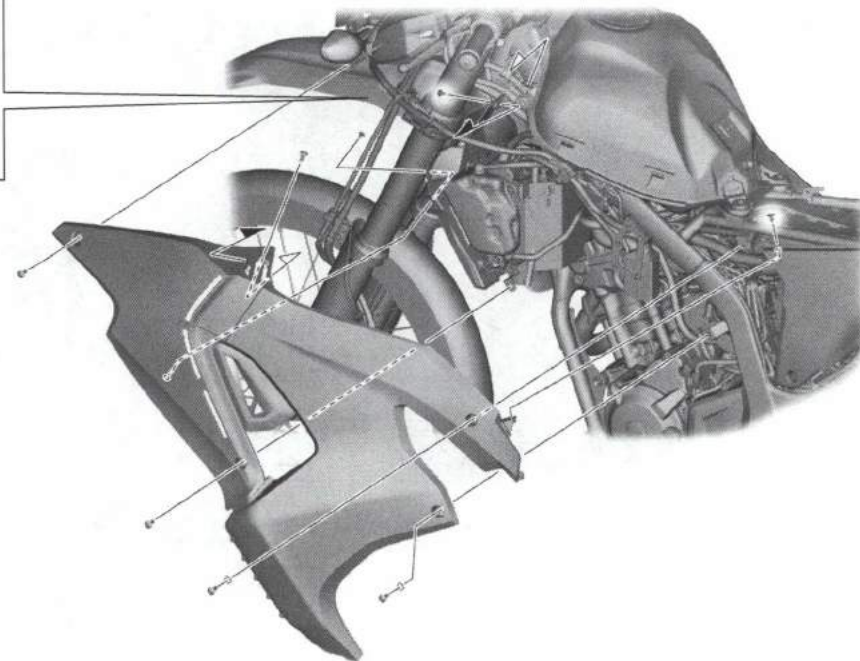
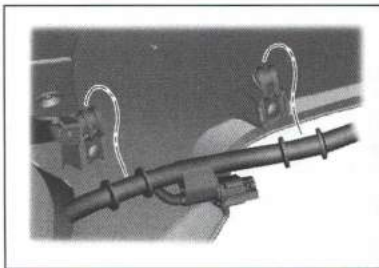

- Seat →3-5
- Front under guard →3-7

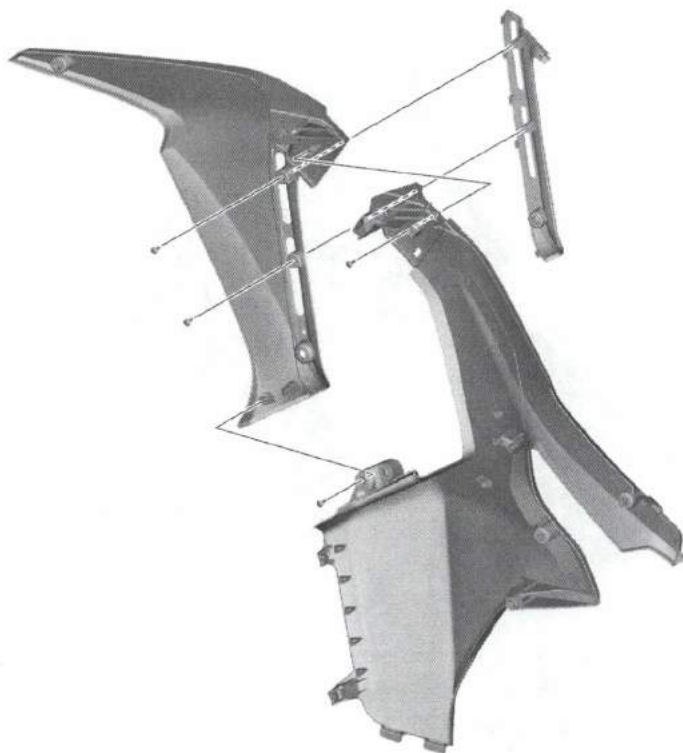



Standard type

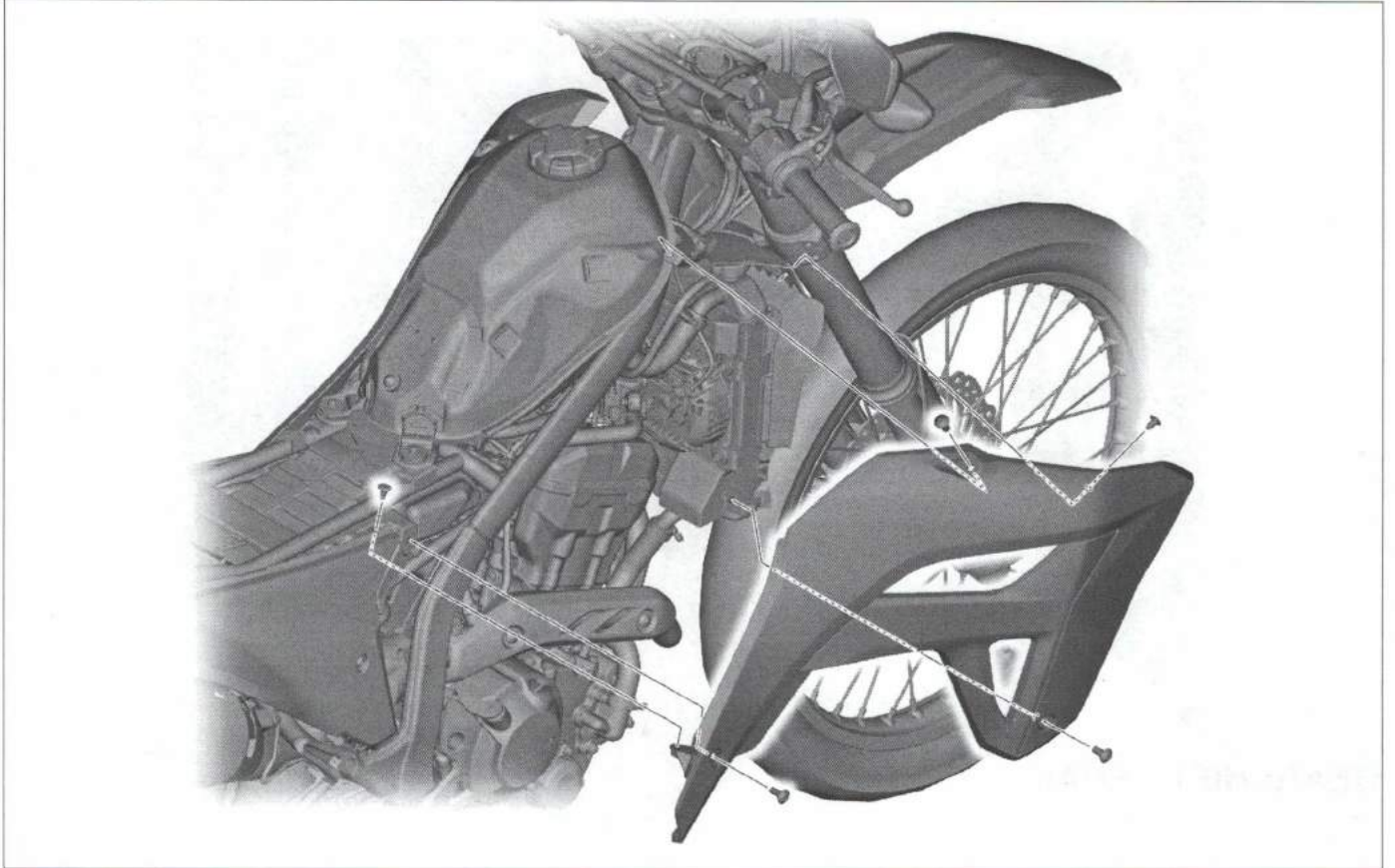

• Seat →3-5

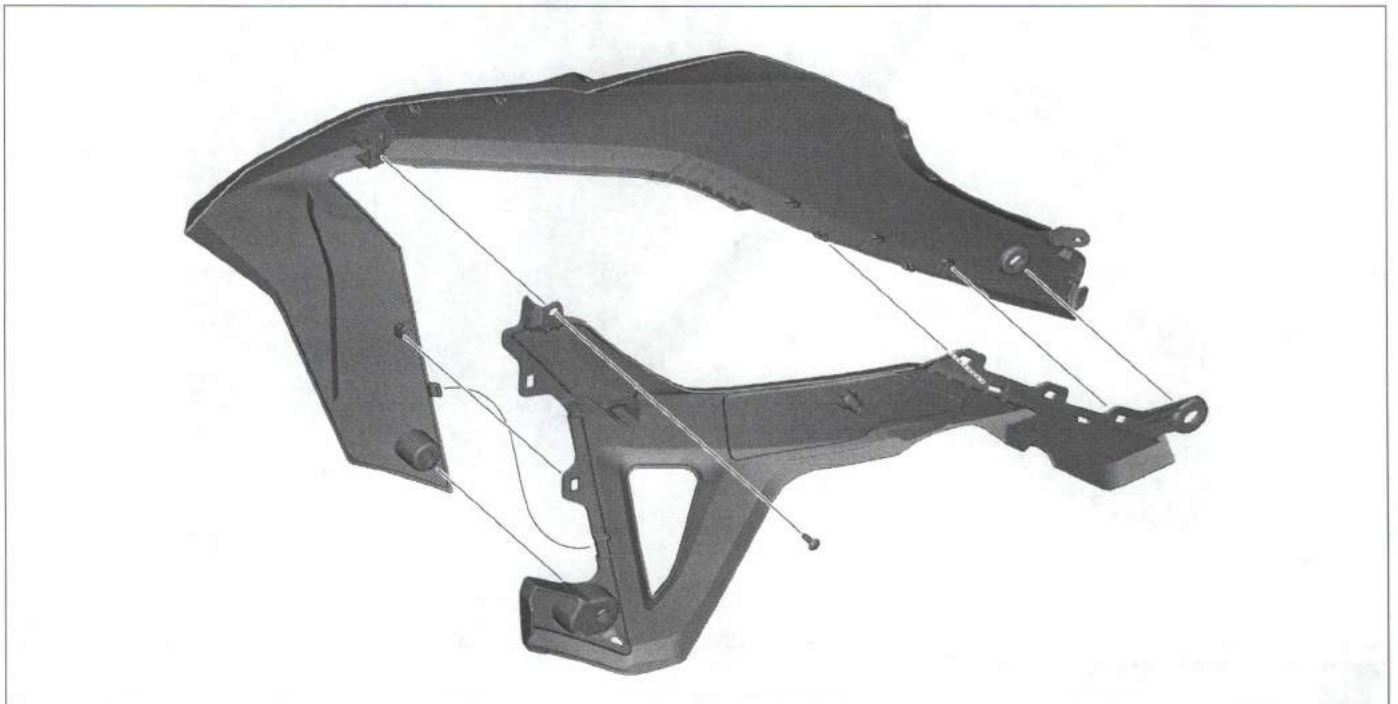



DRIVE SPROCKET COVER

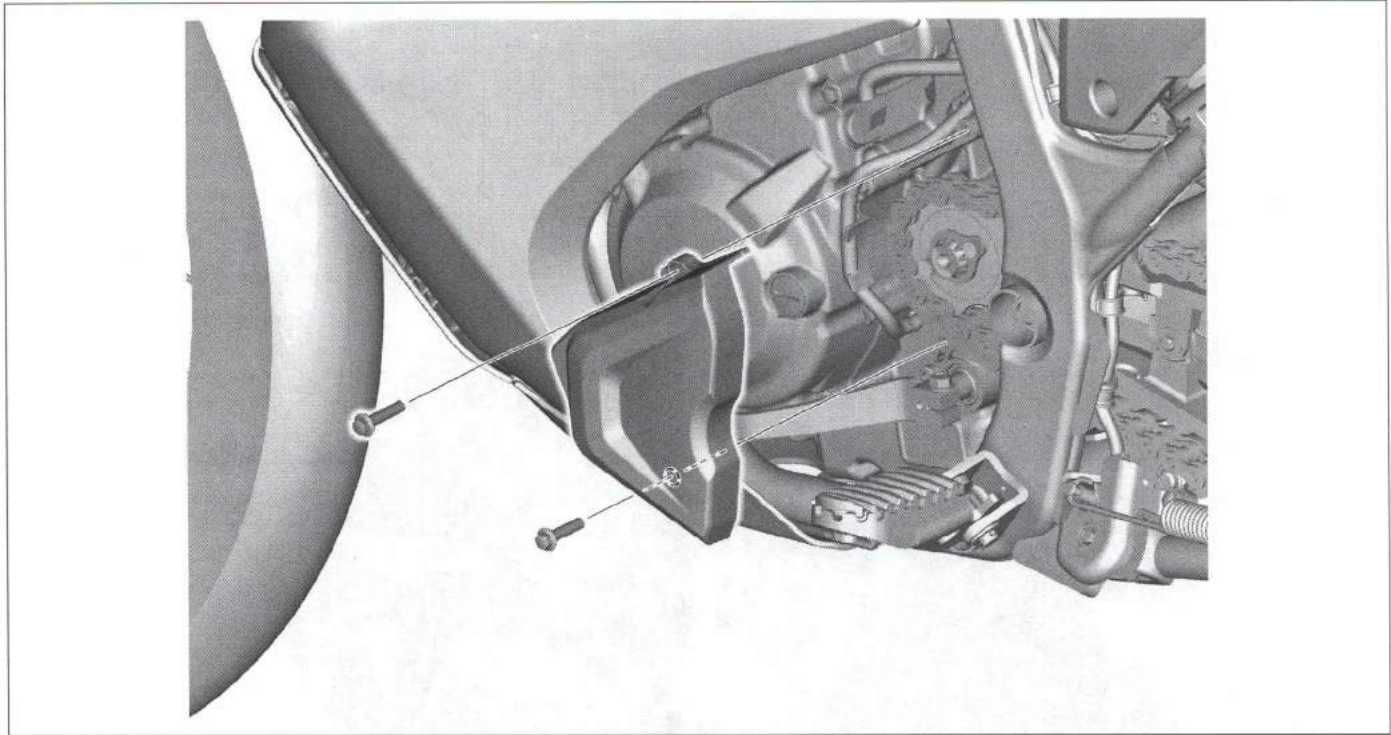

GEARSHIFT PEDAL

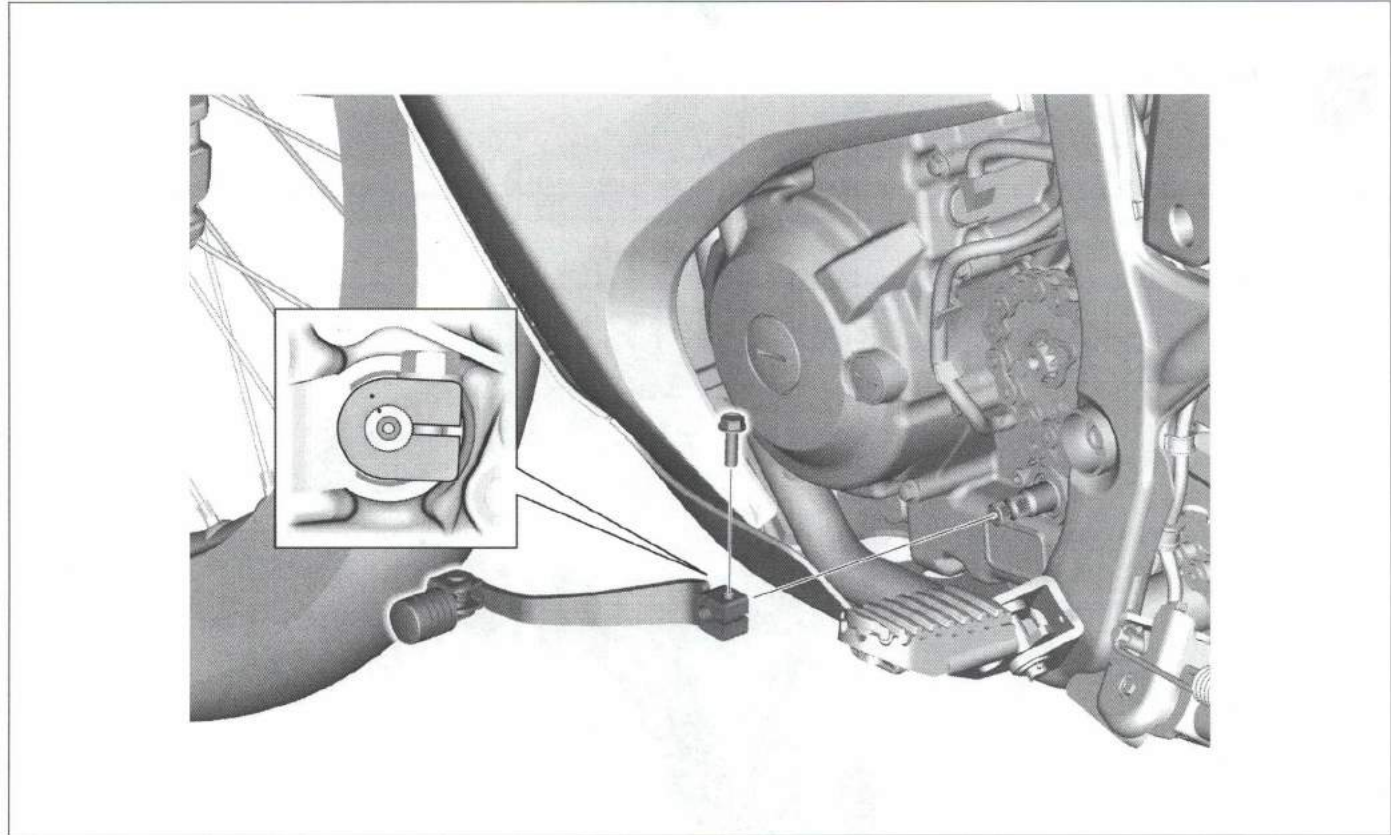

• Drive sprocket cover →3-16



REAR FENDER B

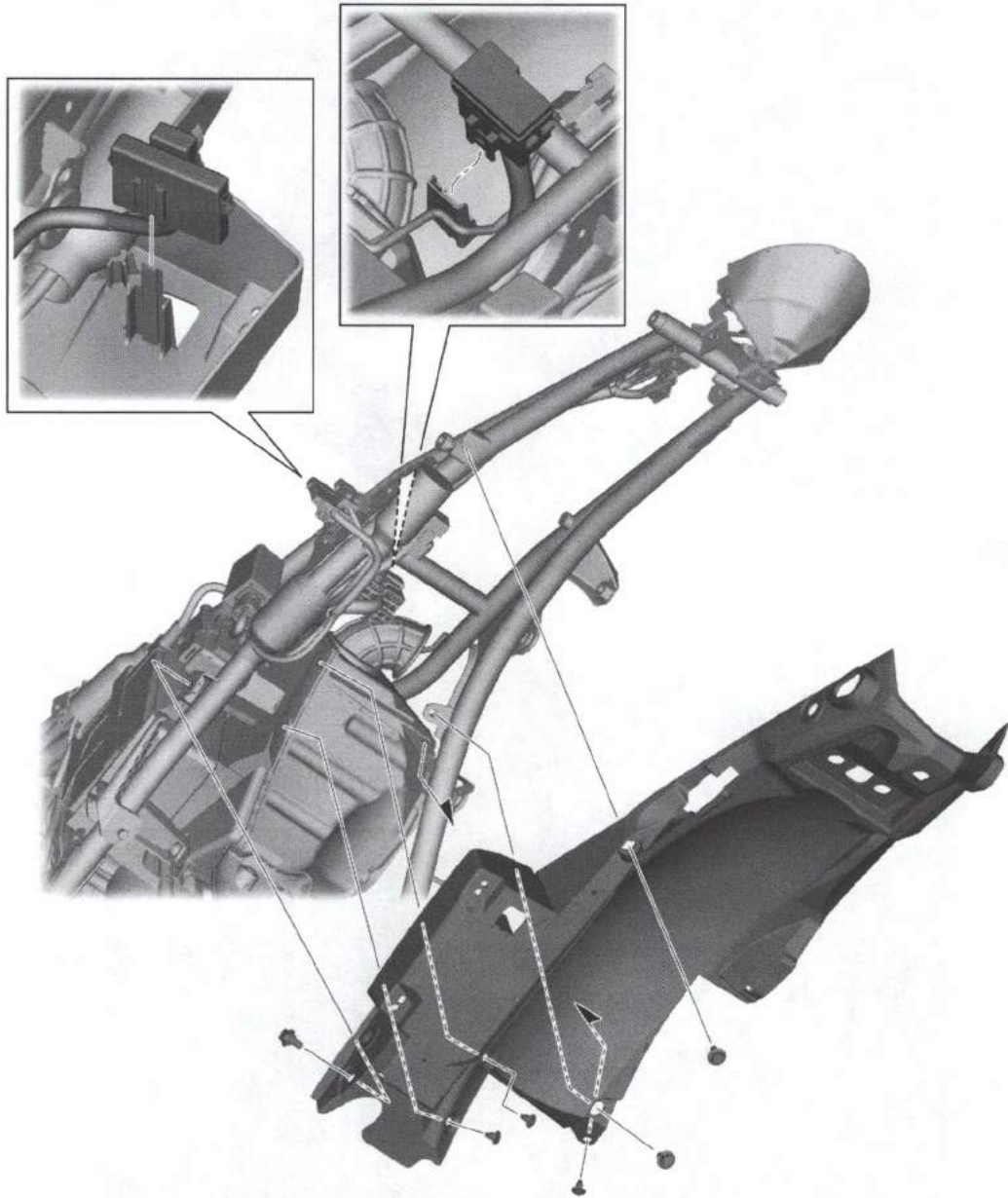

- Rear fender →3-8
- Number plate bracket →3-9
- Muffer →3-24
- Helmet holder →3-19



HEEL GUARD

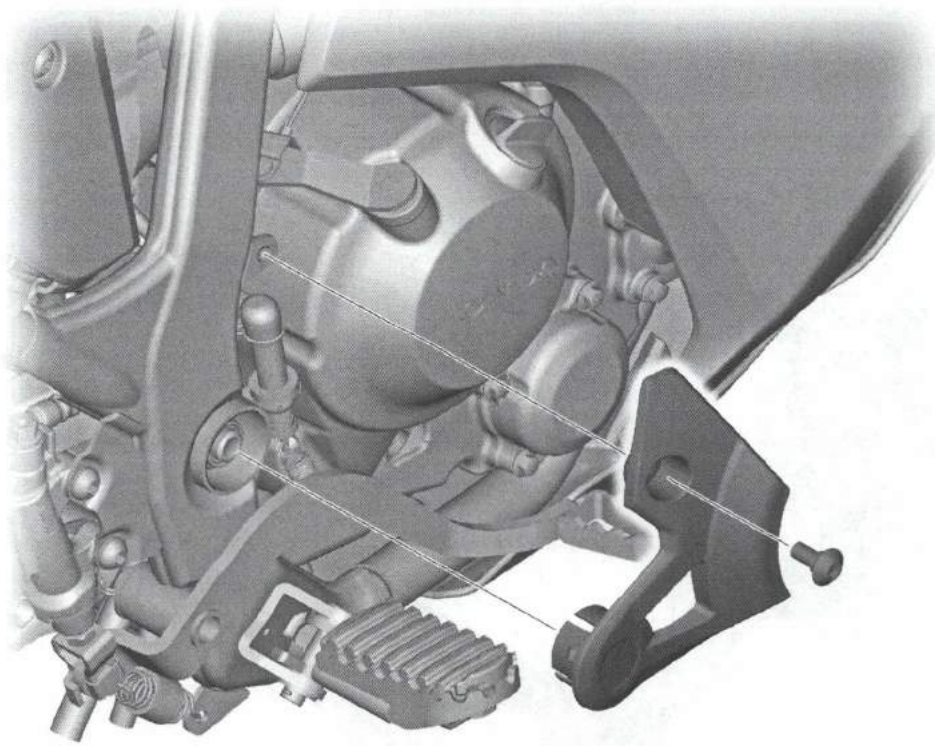

MUD GUARD

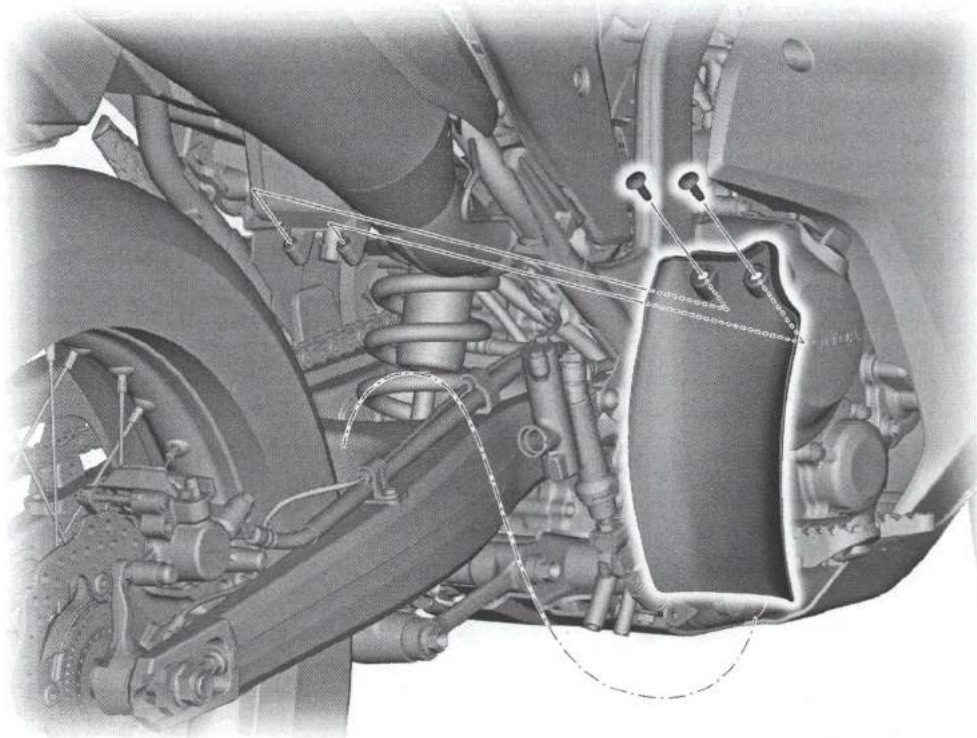



HELMET HOLDER

Y18047

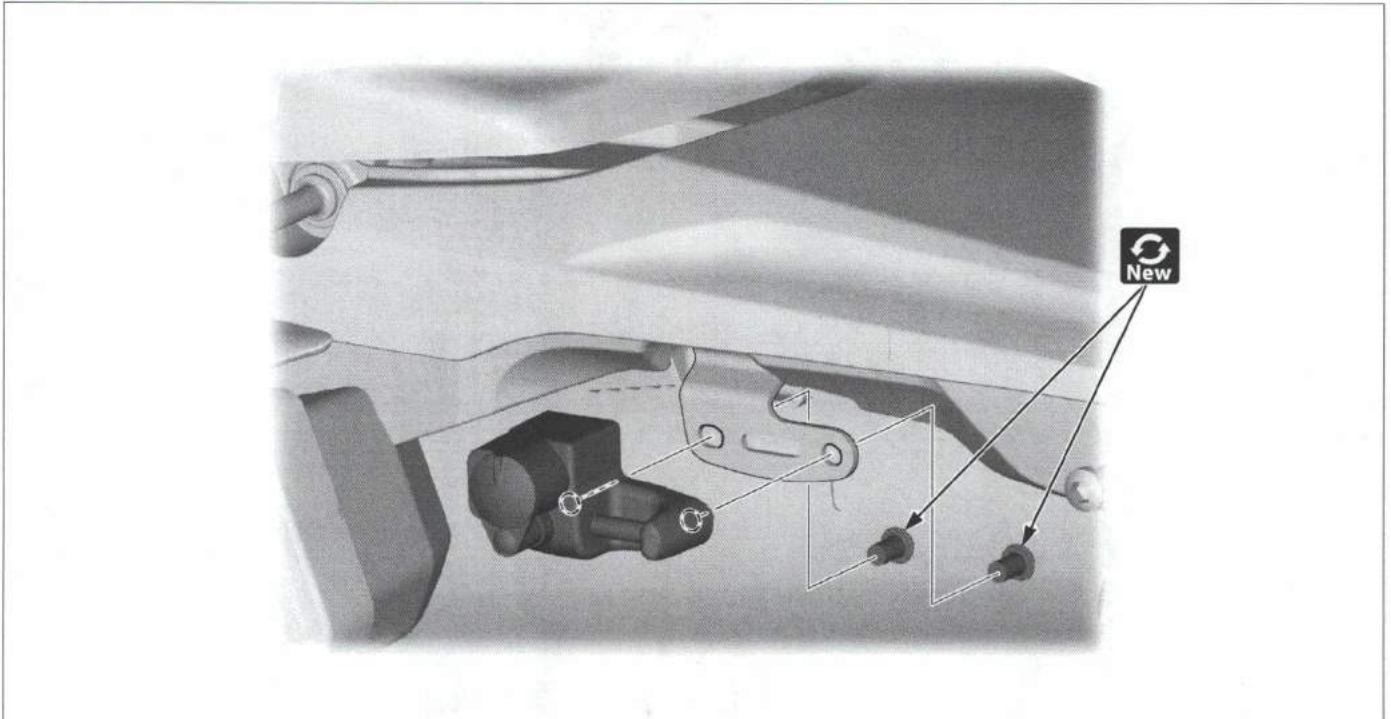

CHAIN CASE

Y18048

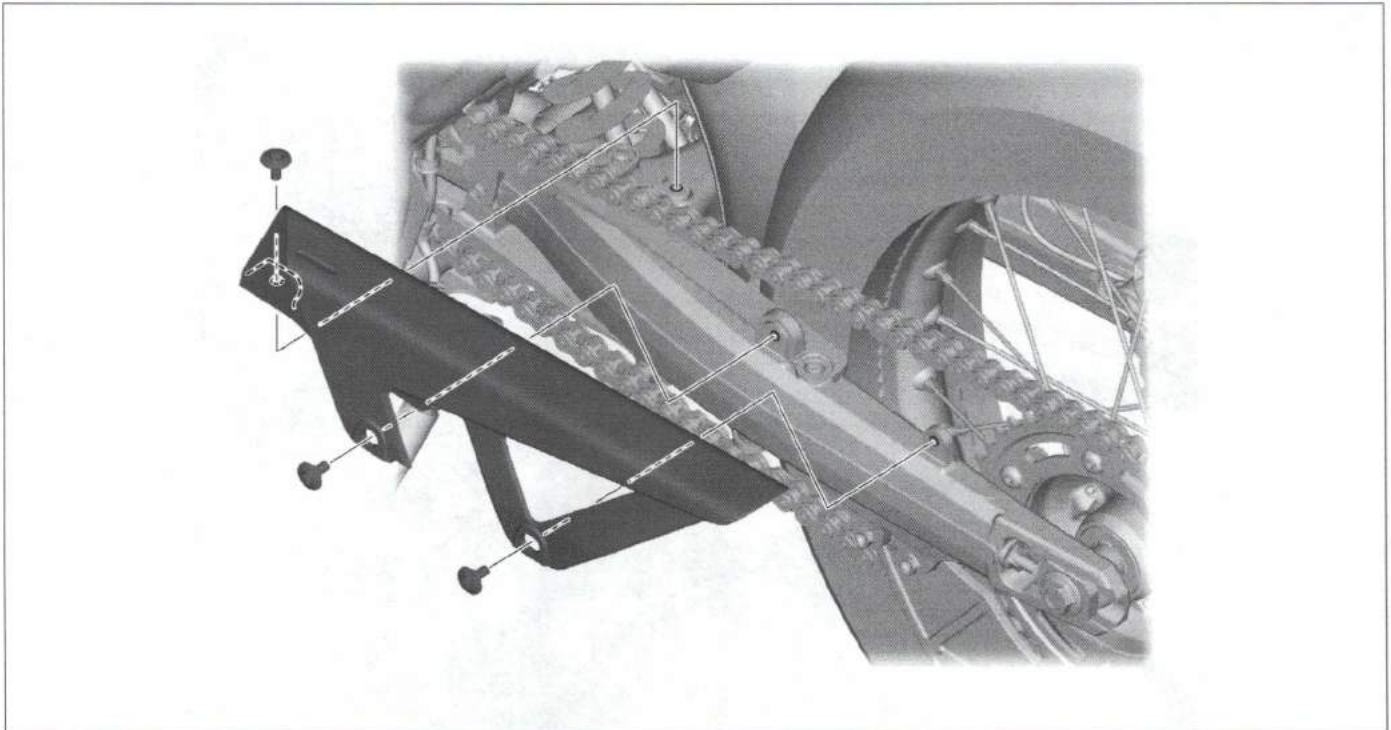



RADIATOR GUARD

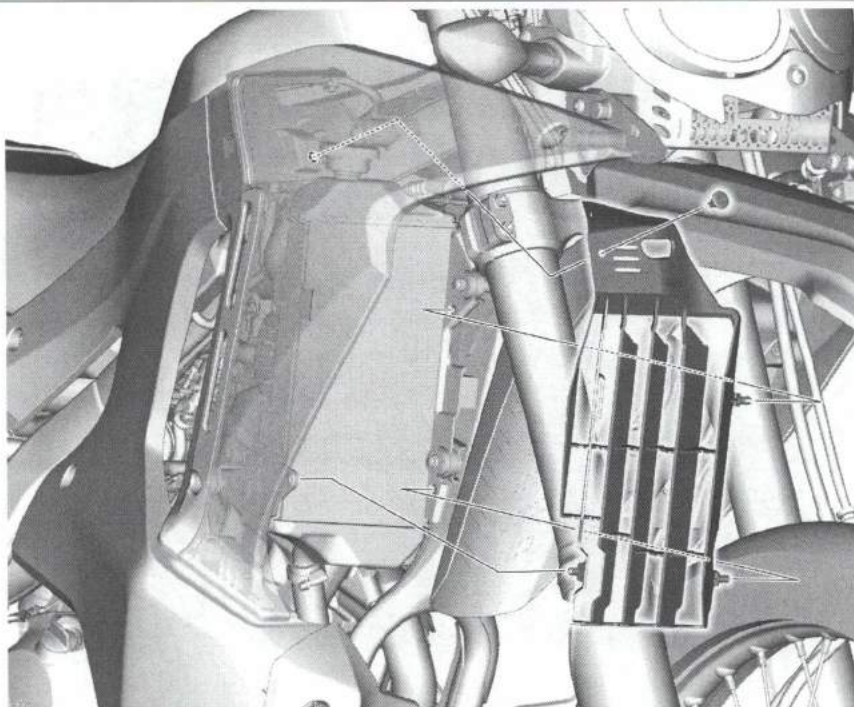

MUFFLER GUARD

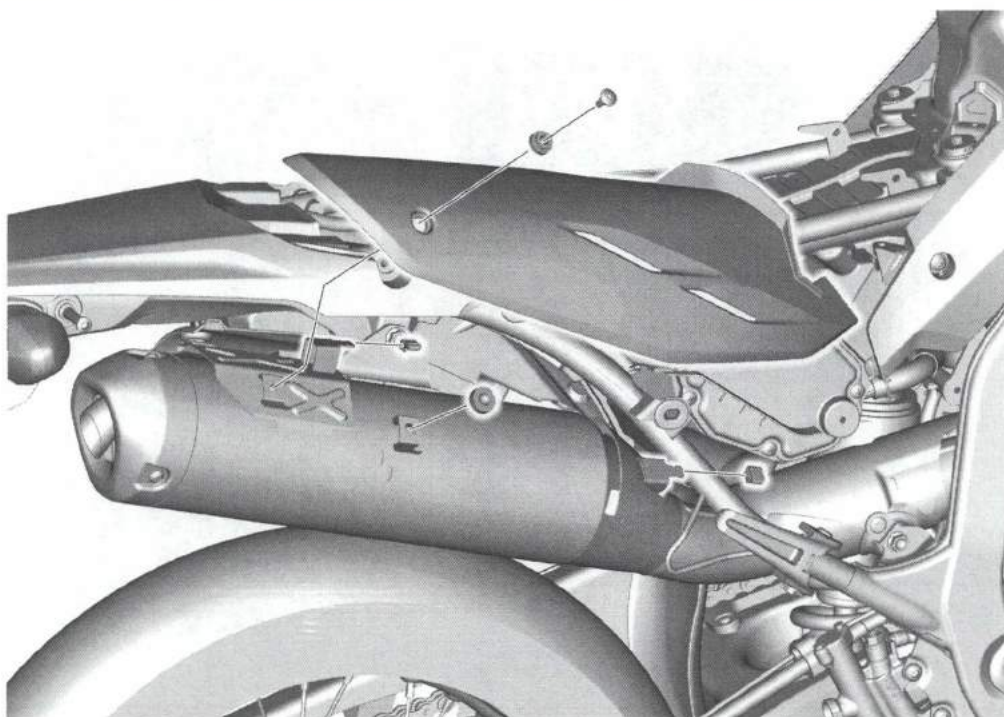

• Side cover →3-8



TOOL BOX

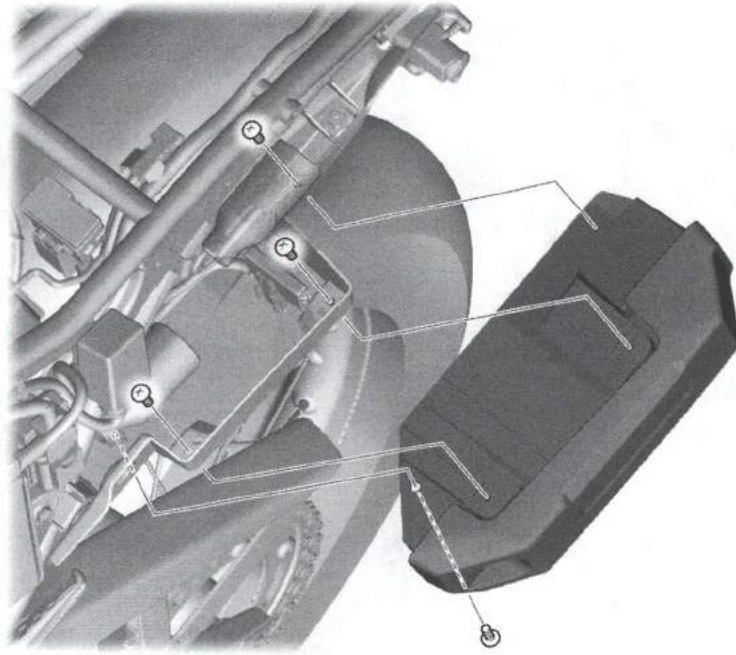

- Rear fender → 3-8
- Side cover → 3-8





BATTERY BOX

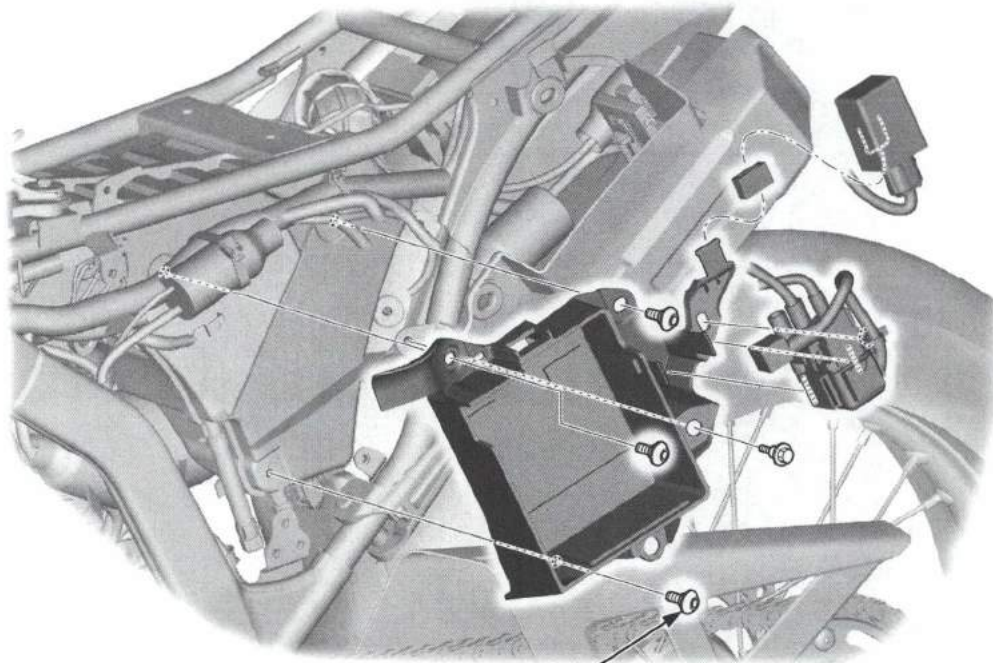

 7.0 N·m



• Battery →4-51



SIDESTAND

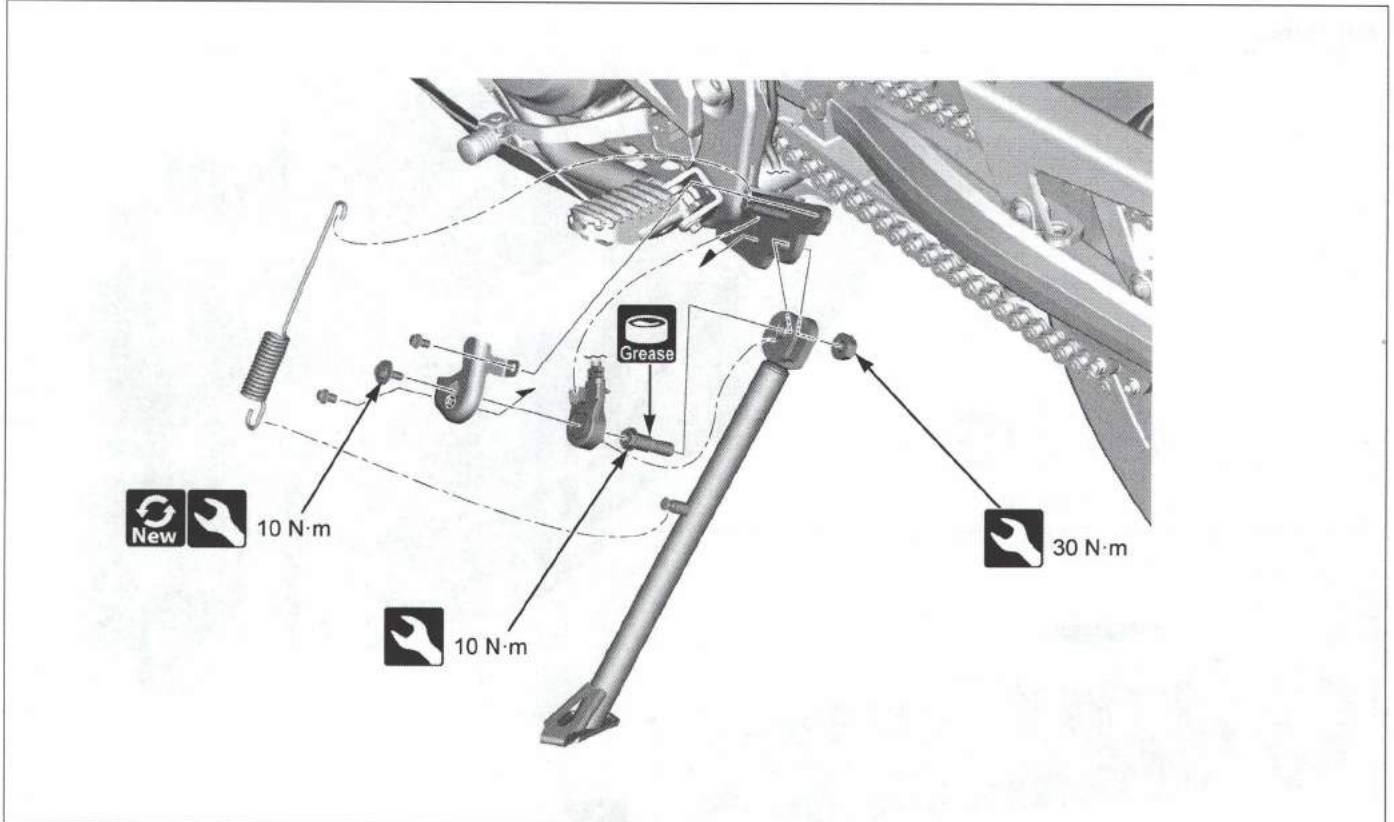



EXHAUST PIPE/MUFFLER

Rally type

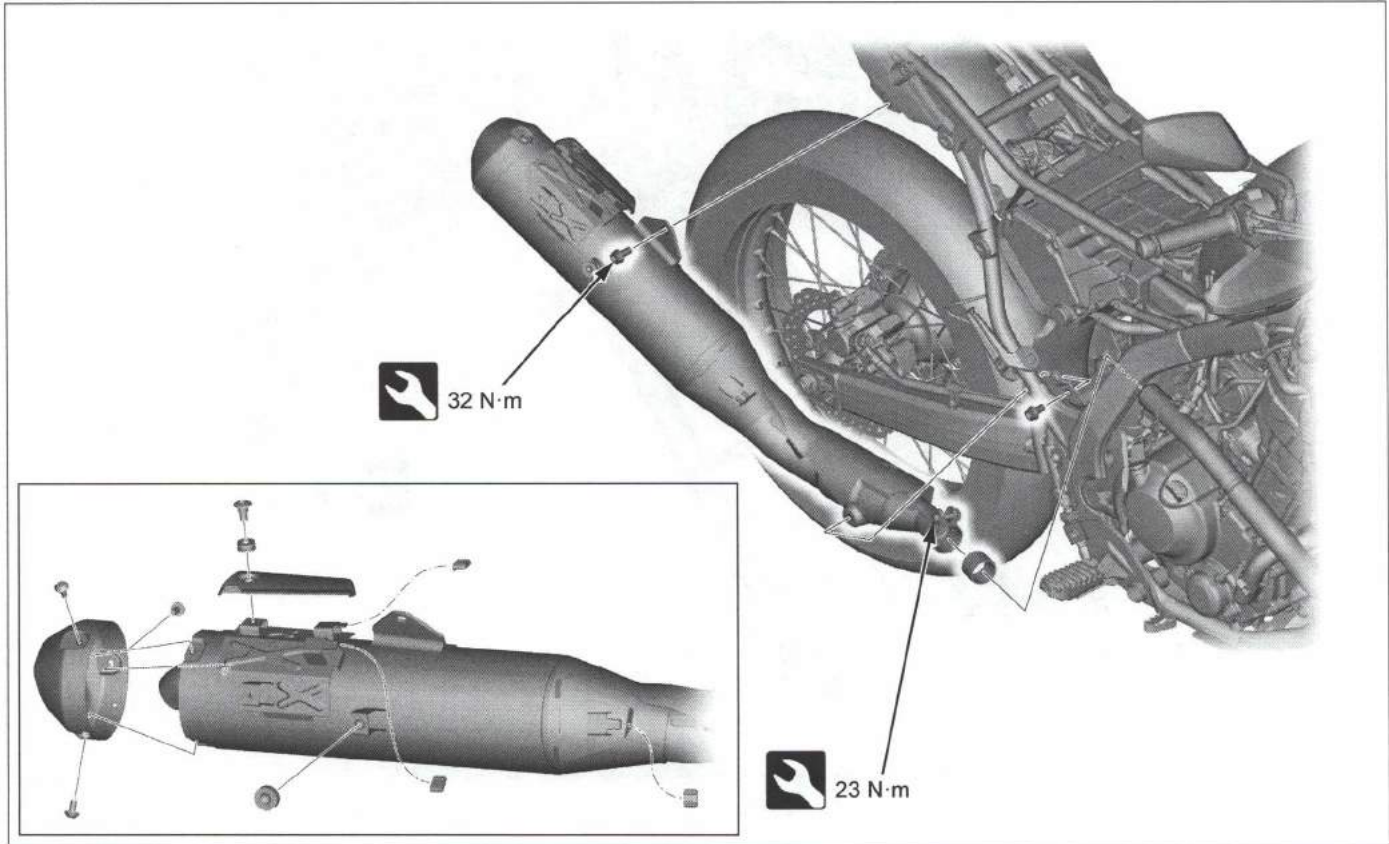

- Fuel tank shroud →3-13
- Side cover →3-8
- Muffler guard →3-20

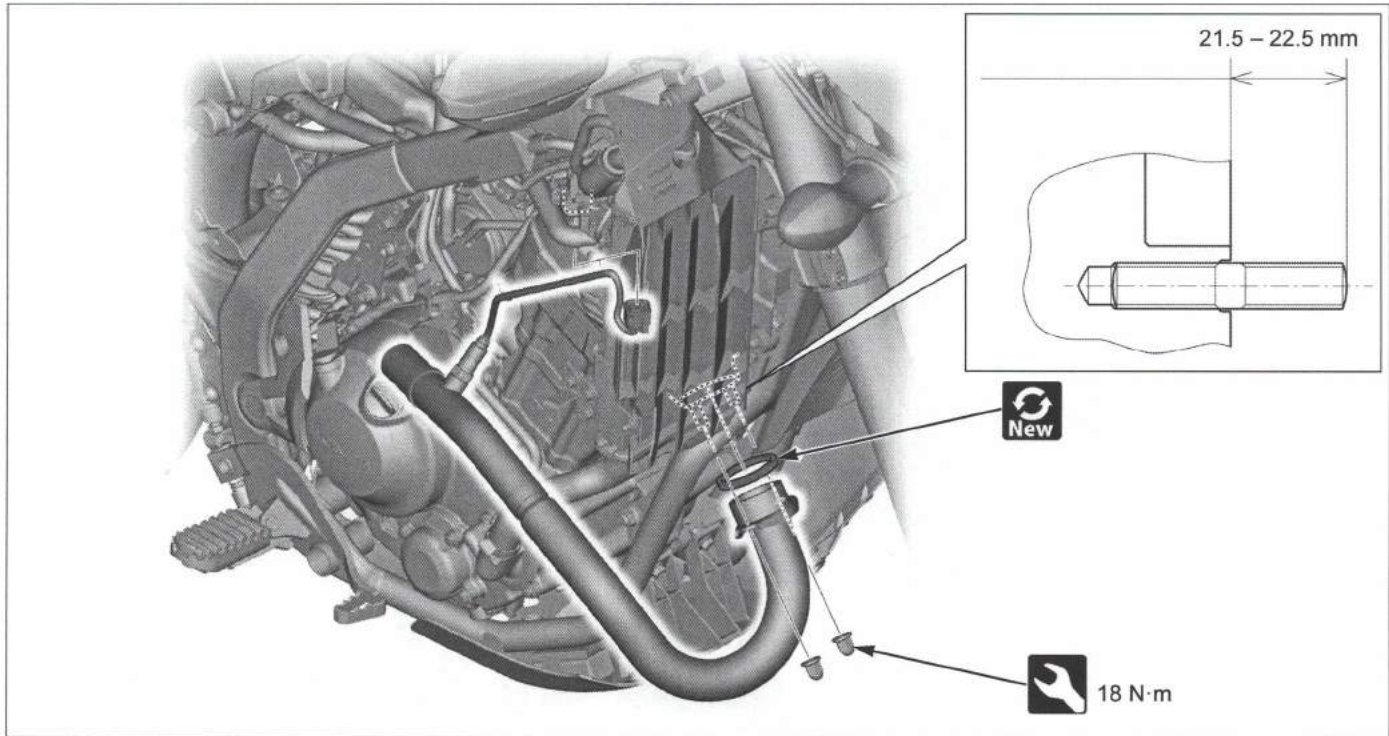



Standard type

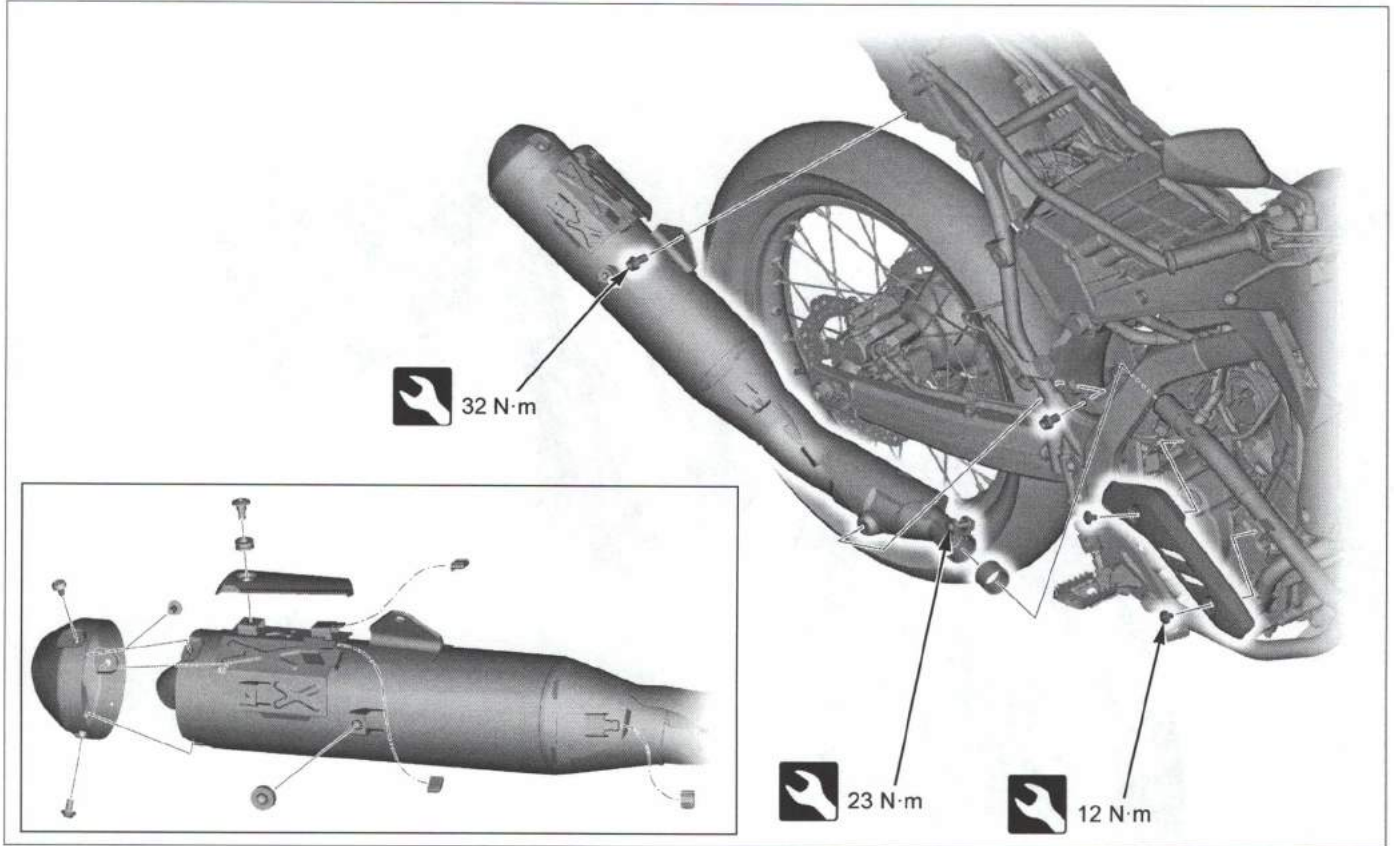

- Fuel tank shroud →3-13
- Side cover →3-8
- Muffler guard →3-20

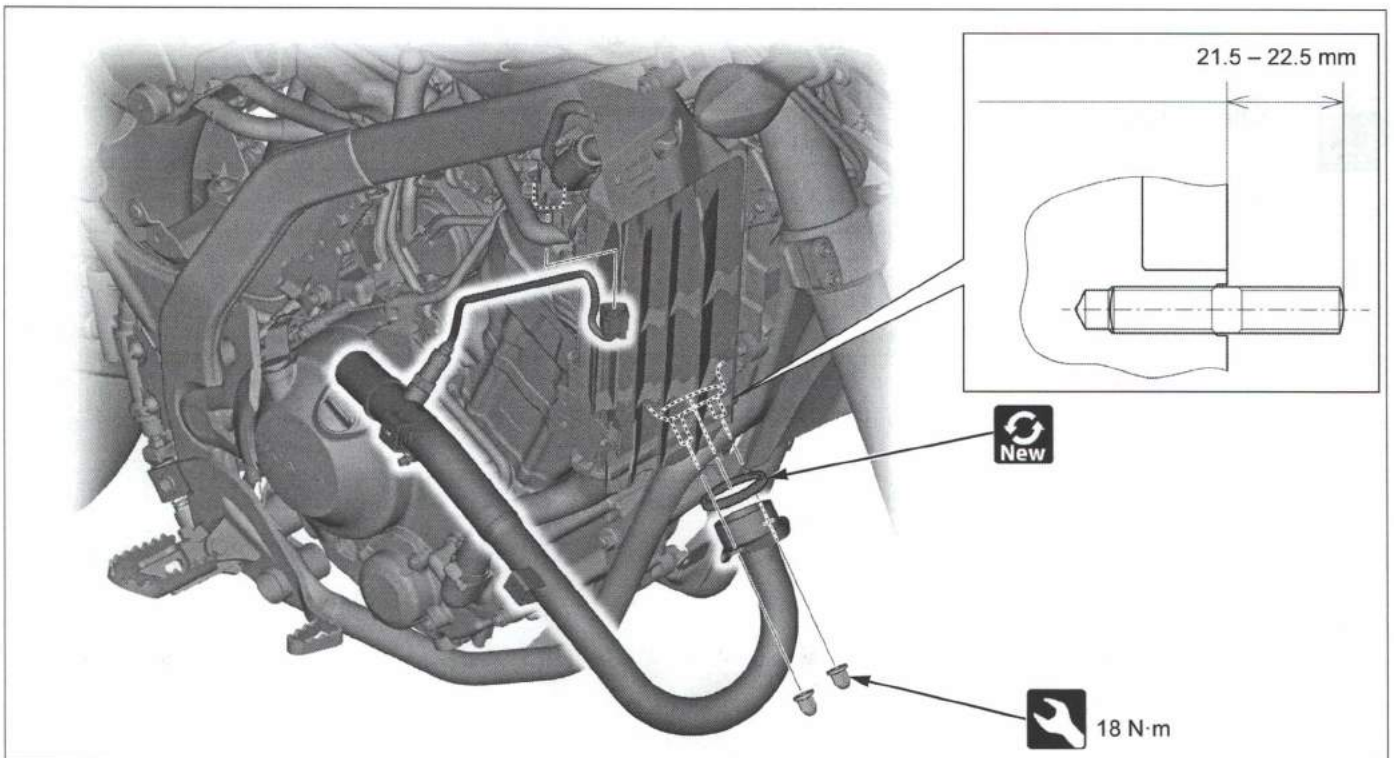



FRONT WHEEL

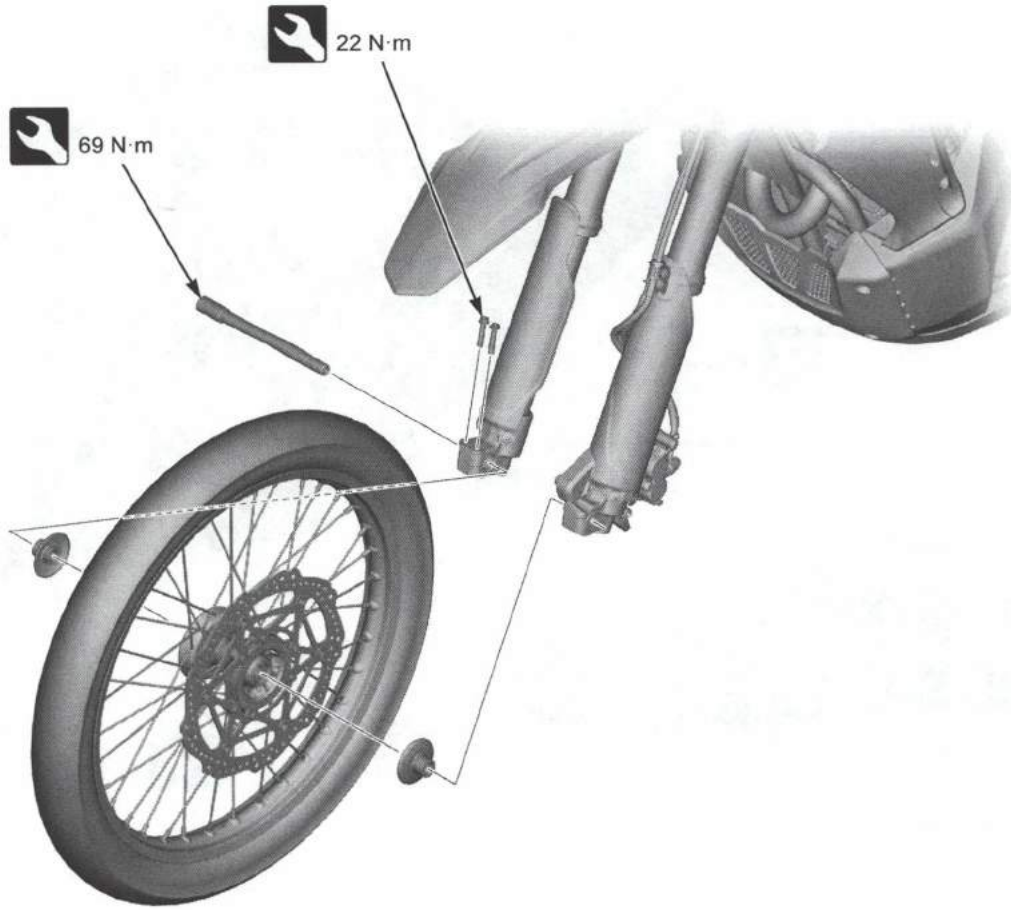

• Wheel inspection

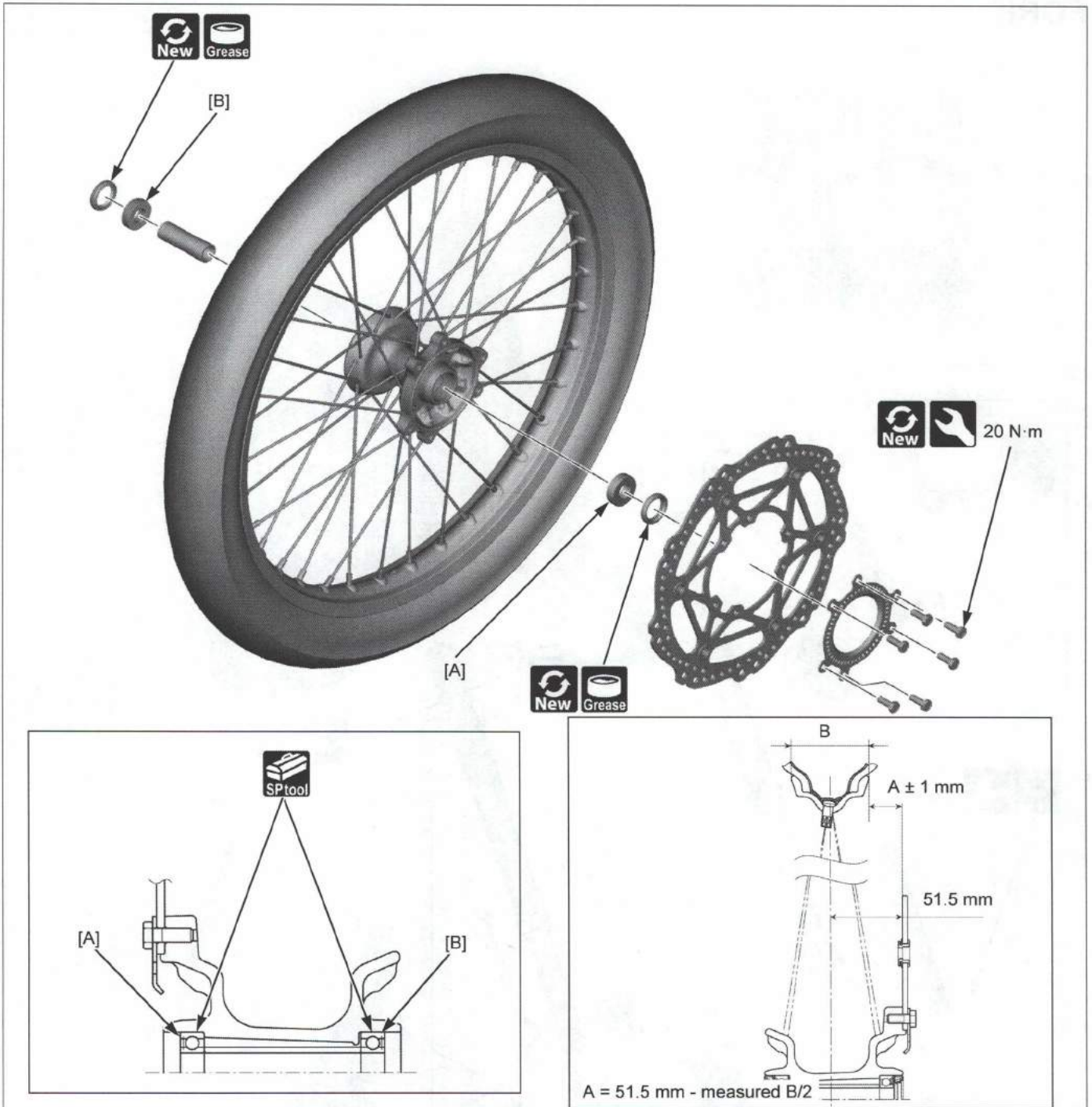

- Install the bearing remover head into the bearing. From the opposite side, install the bearing remover shaft and drive out the bearing from the wheel hub.

Remover head, 17 mm: 07746-0050500

Bearing remover shaft: 07746-0050100



- Drive in a new left bearing [A] squarely with its sealed side facing outside until it is fully seated.
- Install the distance collar.
- Drive in a new right bearing [B] squarely with its sealed side facing outside until it is fully seated on the distance collar.

Attachment, 32 x 35 mm: 07746-0010100

Pilot 17 mm: 07746-0040400

Driver: 07749-0010000



- Wheel disassembly and inspection



FORK

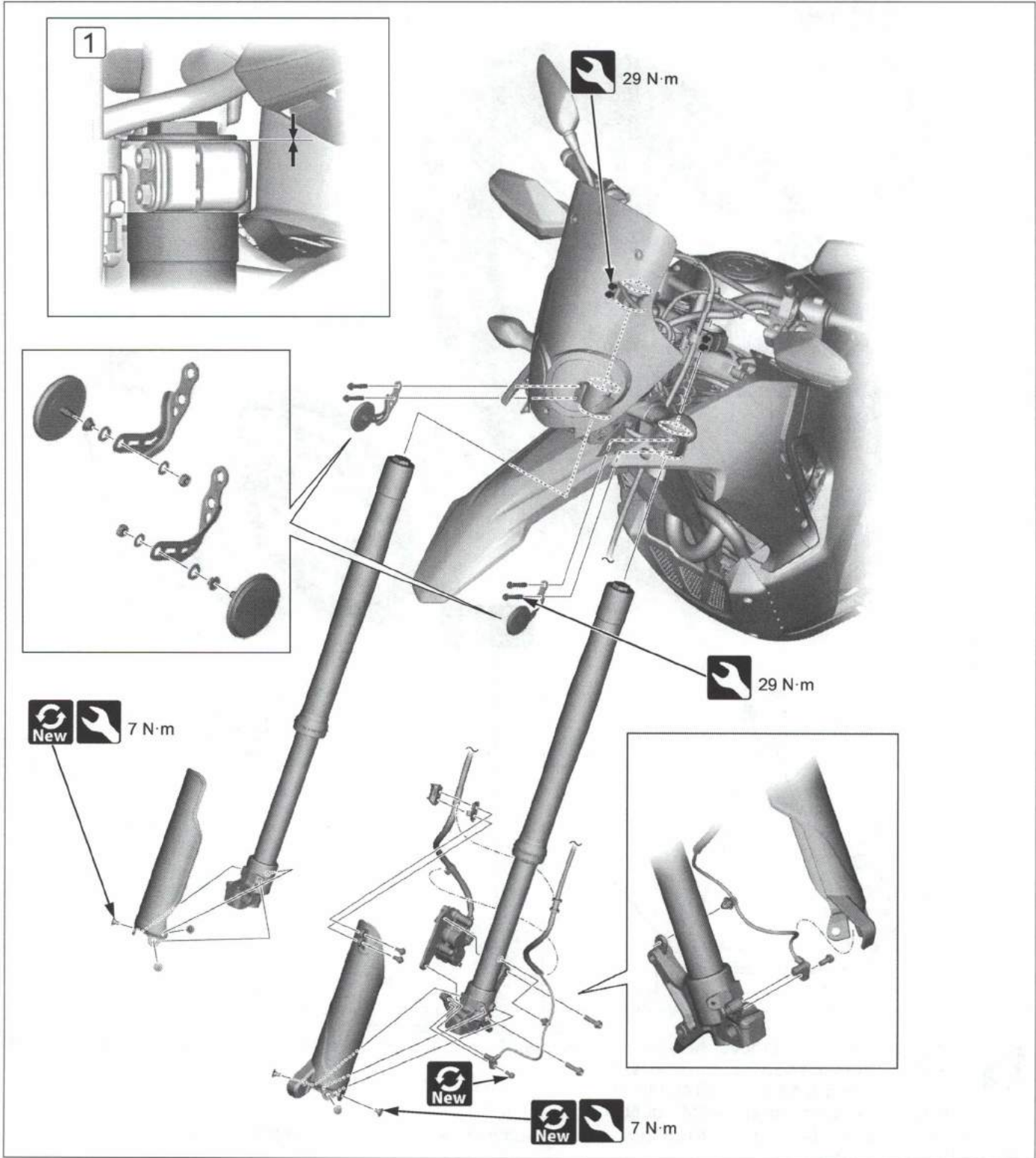

• Front wheel → 3-26







• 1 Install the front fork so that the end of the outer pipe is aligned with the top bridge upper surface.

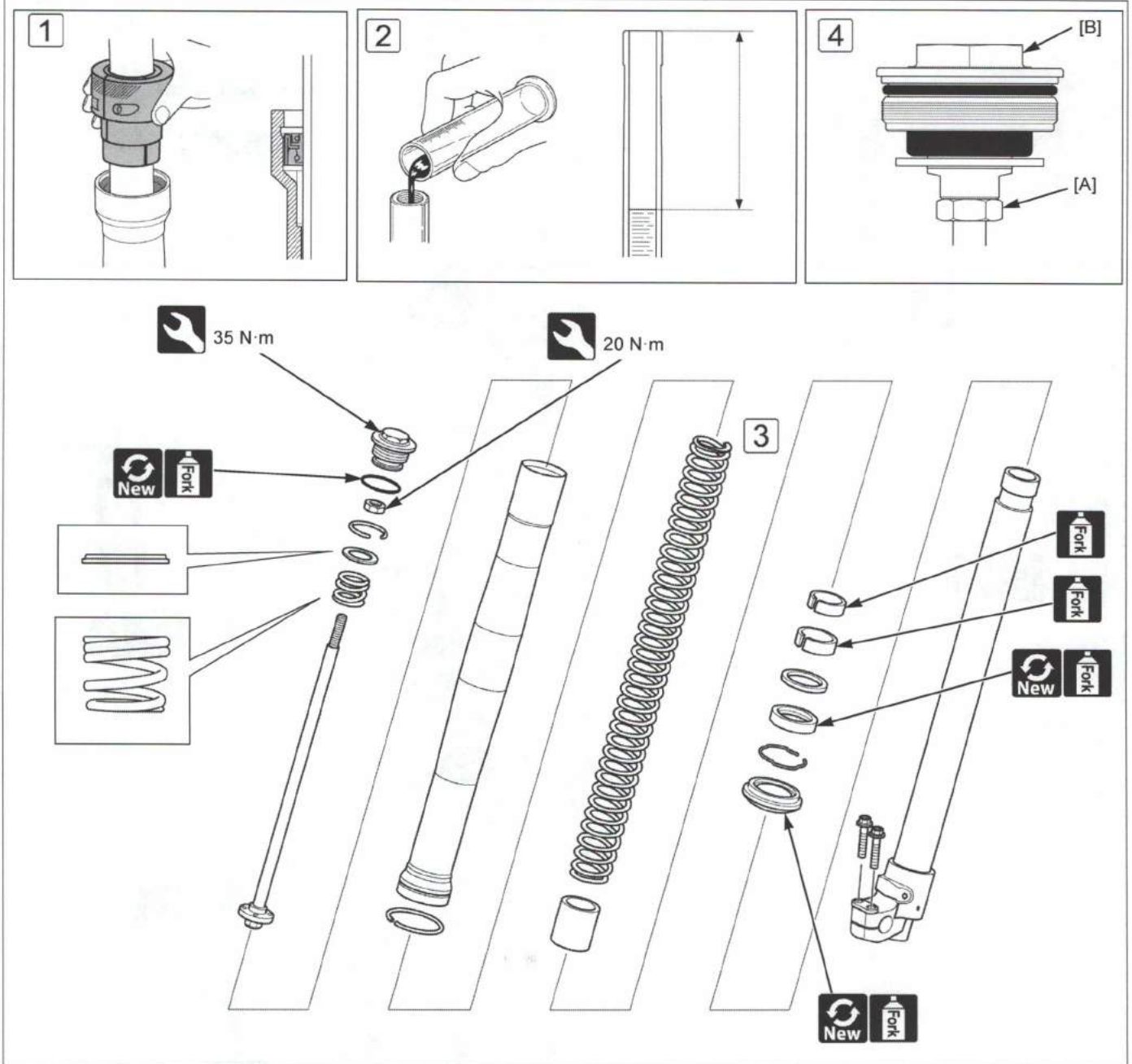

RIGHT SIDE:



- 
 - 1 Drive in the oil seal into the outer tube using the special tool.
Fork seal driver, 45.2 mm: 07KMD-KZ30100
Fork seal driver attachment: 07NMD-KZ30101
- 
 - 2 Pour the specified amount of recommended fork fluid into the fork pipe.
RECOMMENDED FORK FLUID: Fork Fluid (viscosity: 10W)
FORK FLUID CAPACITY: → 1-13
 - Compress the fork leg fully and measure the fluid level from the top of the outer tube.
FORK FLUID LEVEL: → 1-13
- 
 - 3 Install the fork spring with its tightly wound coil side facing up.
 - 4 Hold the fully seated fork rod nut [A] and tighten the fork cap [B].







- Fork disassembly and inspection

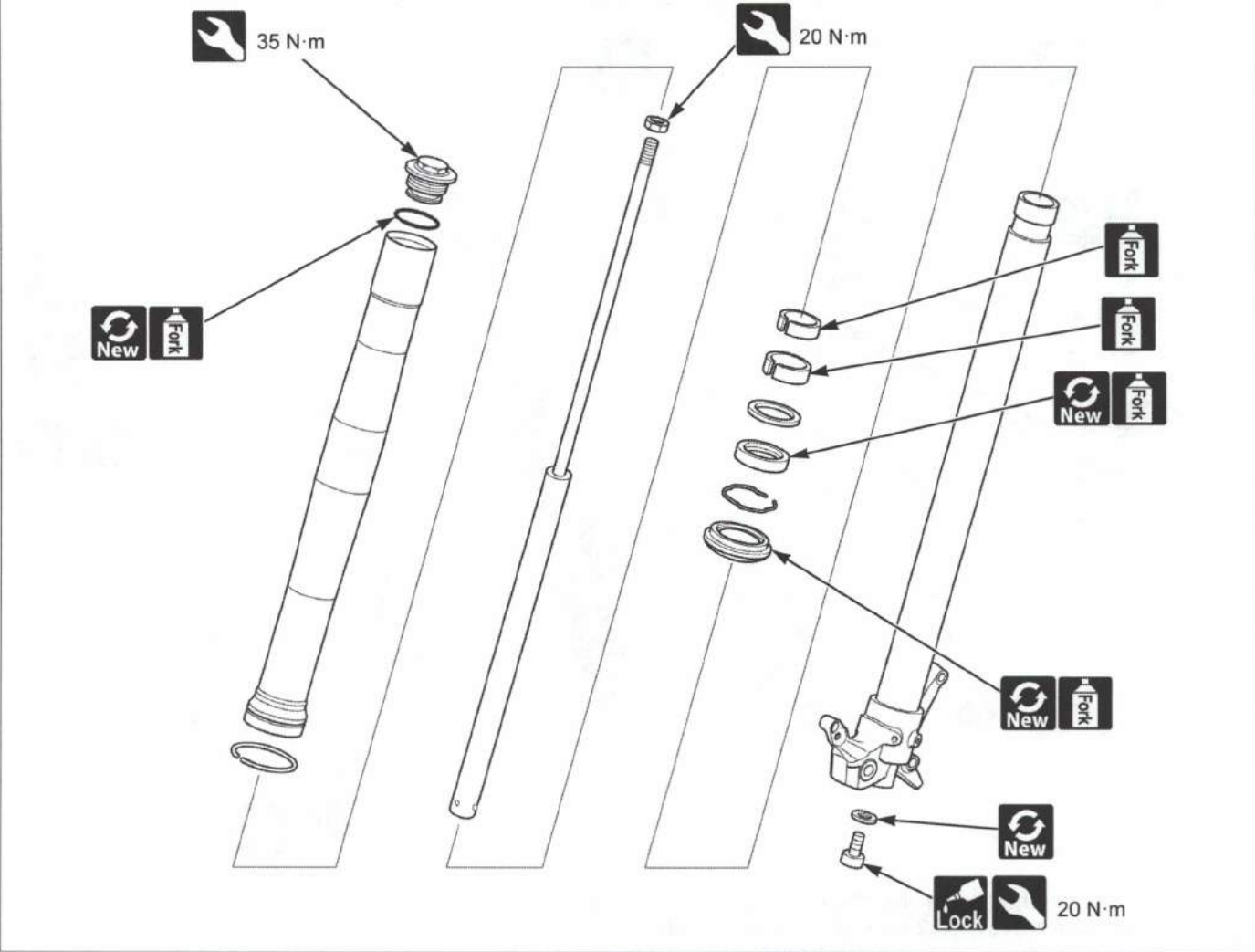
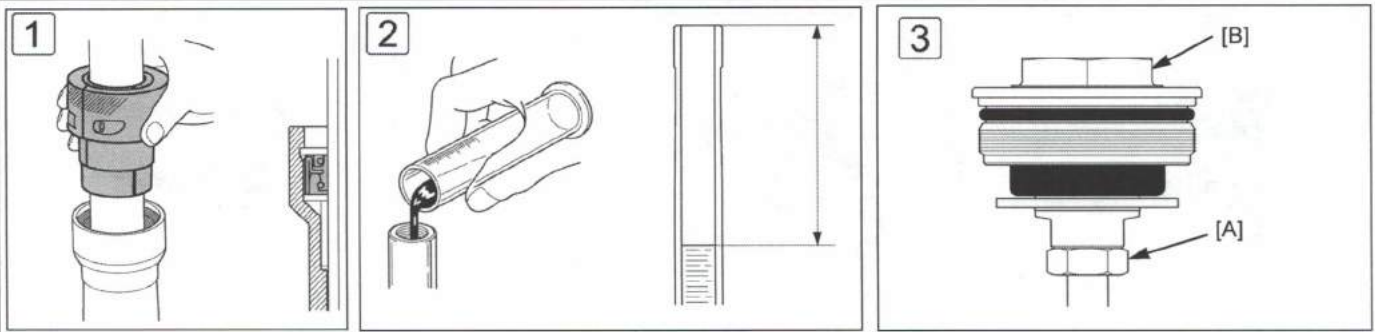

FRAME & CHASSIS

LEFT SIDE:



- 
 • 1 Drive in the oil seal into the outer tube using the special tool.
Fork seal driver, 45.2 mm: 07KMD-KZ30100
Fork seal driver attachment: 07NMD-KZ30101
- 
 • 2 Pour the specified amount of recommended fork fluid into the fork pipe.
RECOMMENDED FORK FLUID: Fork Fluid (viscosity: 10W)
FORK FLUID CAPACITY: → 1-13
 • Compress the fork leg fully and measure the fluid level from the top of the outer tube.
FORK FLUID LEVEL: → 1-13
- 
 • 3 Hold the fully seated fork rod nut [A] and tighten the fork cap [B].
- 
 • Fork disassembly and inspection



HANDLEBAR

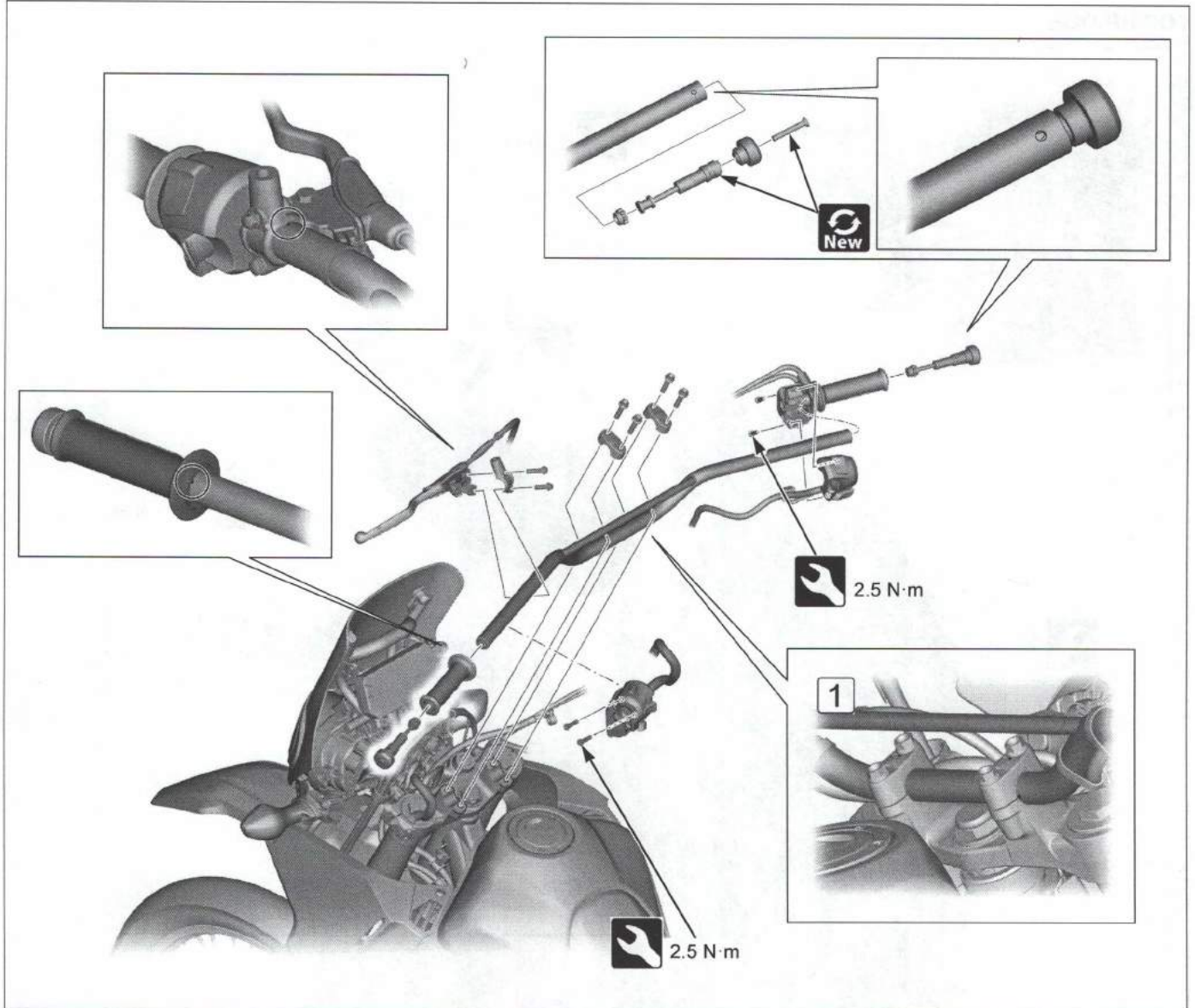

- Rearview mirror →3-4
- Front brake master cylinder →3-37



- **1** Align the upper surface of the lower handlebar holder with the punch mark on the handlebar. Tighten the forward bolts first, then the rear bolts.



STEERING STEM

TOP BRIDGE

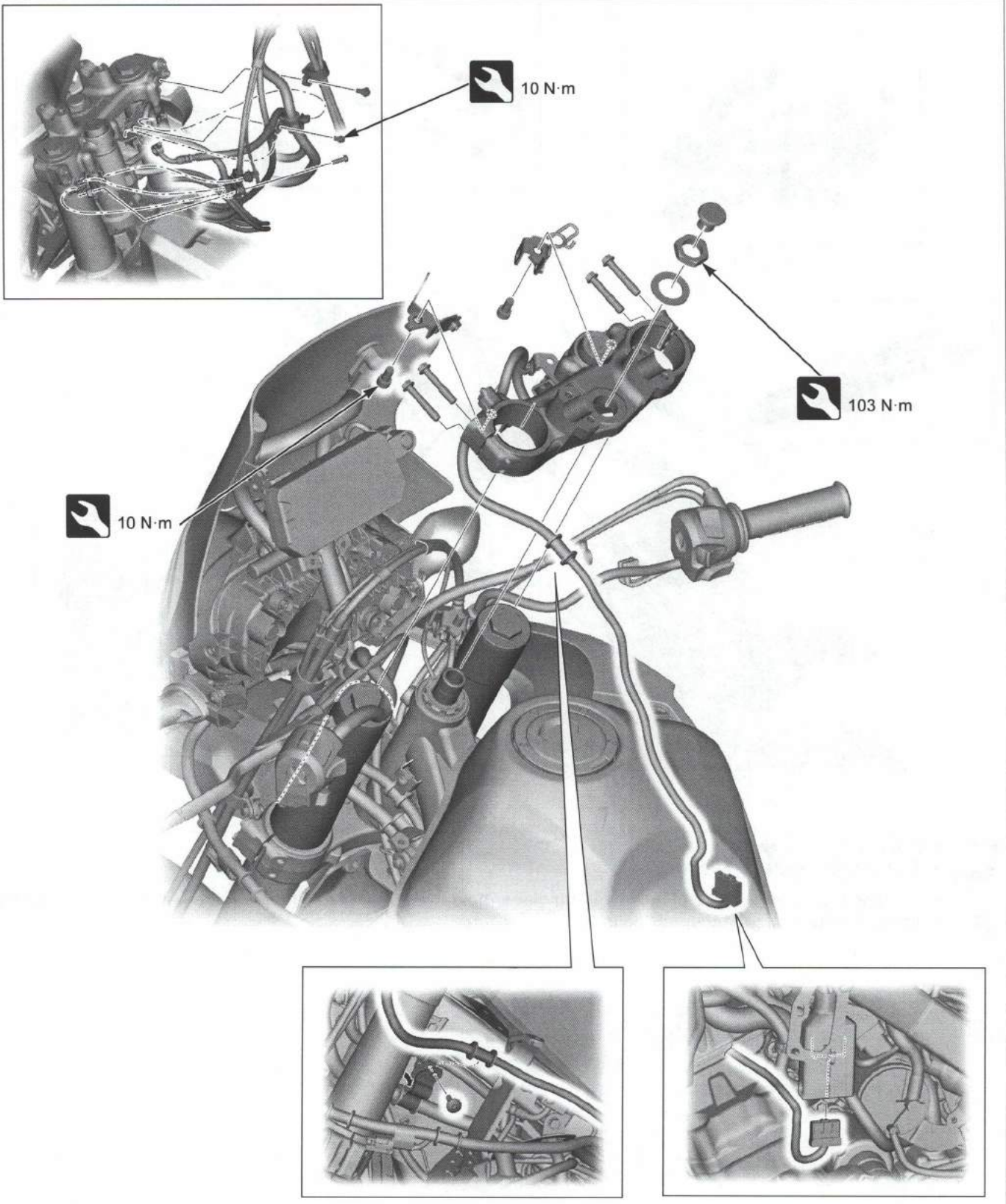

- Handlebar → 3-31
- Left fuel tank shroud → 3-13



BOTTOM BRIDGE

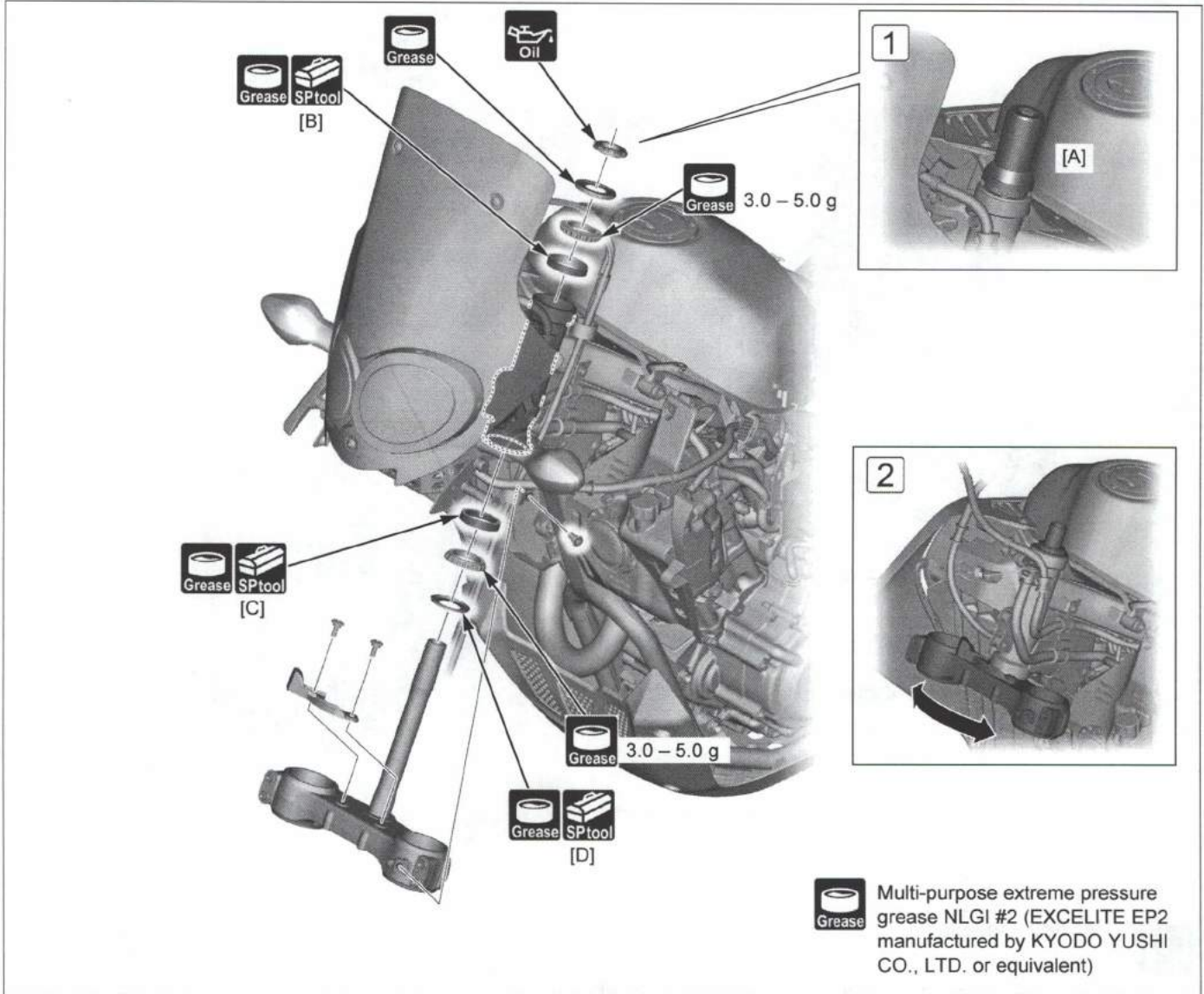

Multi-purpose extreme pressure grease NLGI #2 (EXCELITE EP2 manufactured by KYODO YUSHI CO., LTD. or equivalent)



- Fork →3-28
- Top bridge →3-32
- STEERING STEM:
 - [A] Steering stem socket: 07916-3710101
- STEERING STEM BEARING:
 - [B]/[C] Ball race remover: 07948-4630100, Ball race remover 36 x L340: 07GMD-KS40100



- STEERING STEM BEARING:
 - [D] Driver, 28 mm I.D.: 07946-4300101
- STEERING STEM:
 - [A] Steering stem socket: 07916-3710101
 - 1 Install the adjusting nut. Hold the steering stem and tighten the adjusting nut to the initial torque.
TORQUE: 29.5 N·m
 - 2 Turn the steering stem lock-to-lock five times to seat the bearing. Completely loosen the adjusting nut, and then tighten the adjusting nut to the specified torque.
TORQUE: 4.9 N·m



- Steering disassembly/assembly and inspection



REAR WHEEL

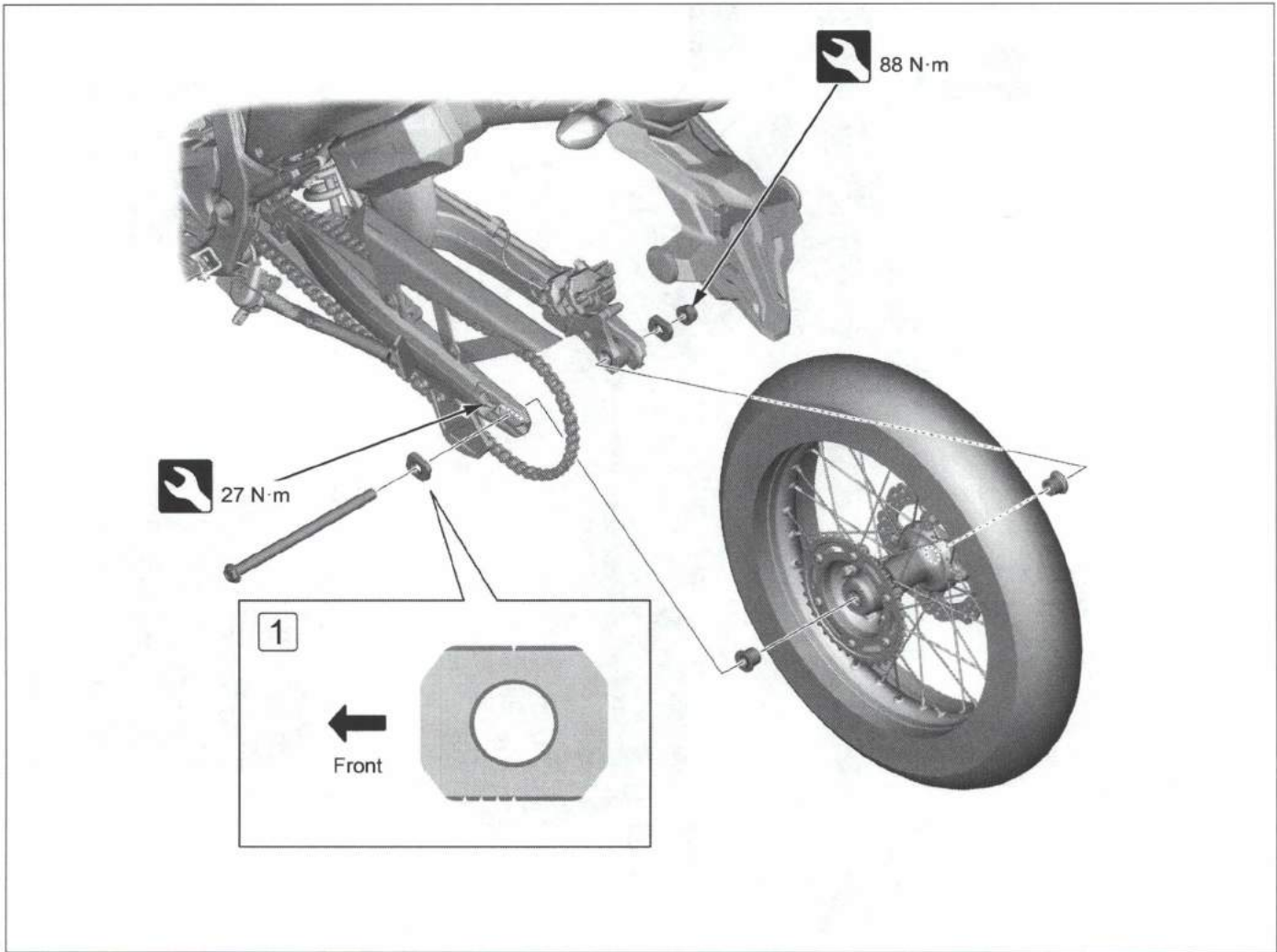

- Wheel inspection



- 1 Install the swingarm plate in the direction as shown.

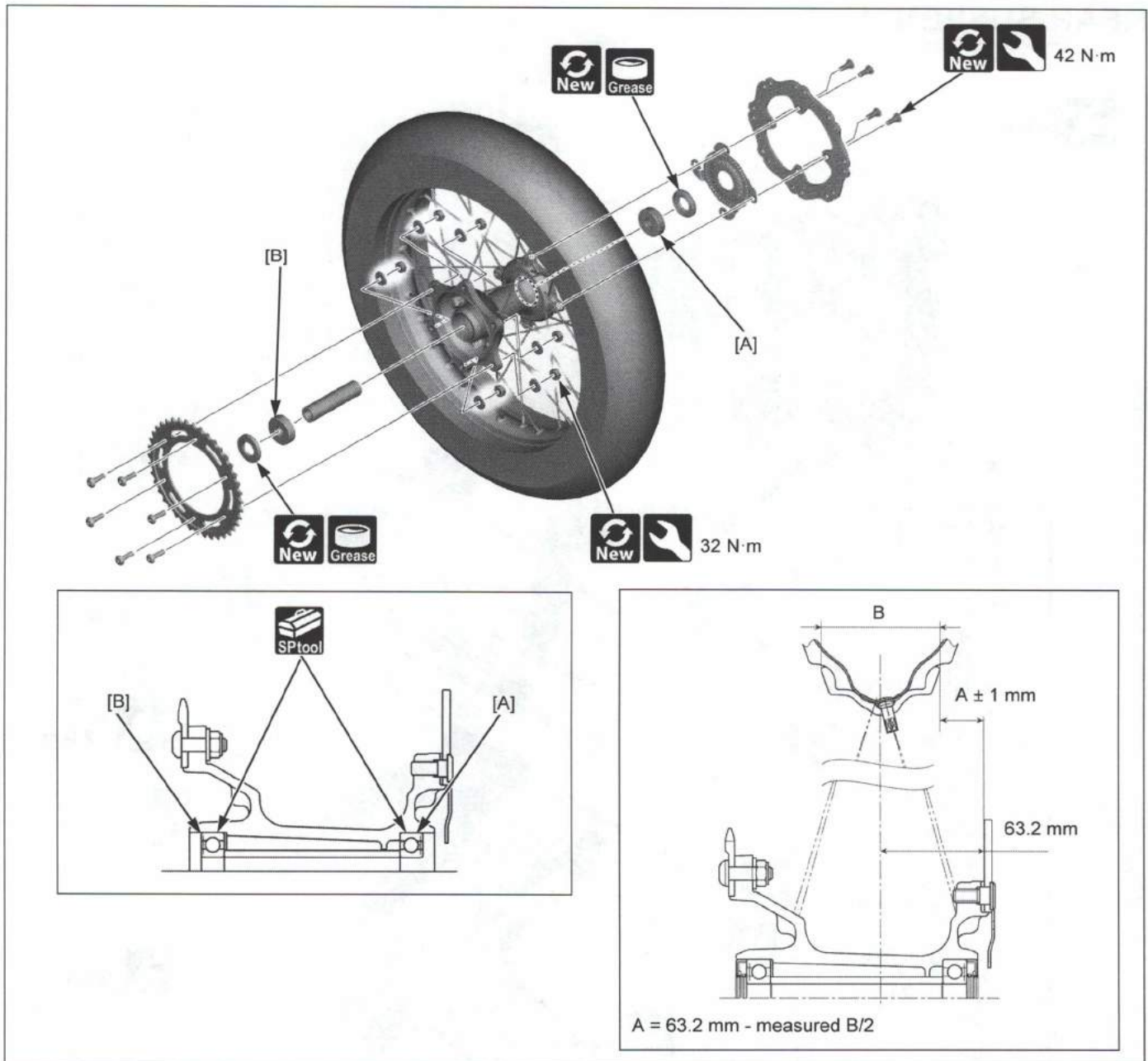

REAR WHEEL



- Install the bearing remover head into the bearing. From the opposite side, install the bearing remover shaft and drive out the bearing from the wheel hub.

Remover head, 17 mm: 07746-0050500
Bearing remover shaft: 07746-0050100



- Drive in a new right bearing [A] squarely with its sealed side facing outside until it is fully seated.
- Install the distance collar.
- Drive in a new left bearing [B] squarely with its sealed side facing outside until it is fully seated on the distance collar.

Attachment, 42 x 47 mm: 07746-0010300
Pilot 17 mm: 07746-0040400
Driver: 07749-0010000



- Wheel disassembly and inspection

Basic



REAR SUSPENSION

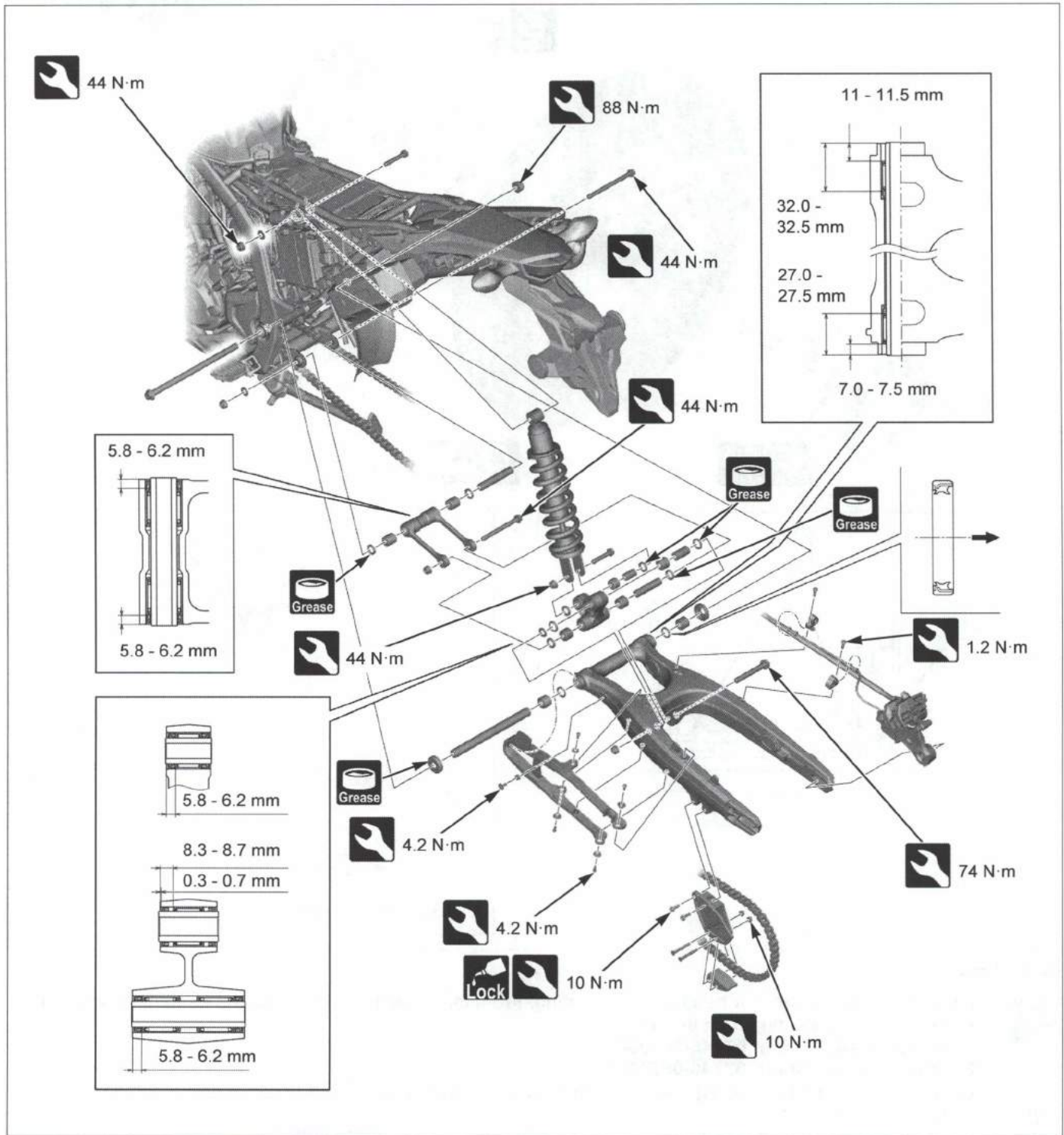

- Fuel tank shroud → 3-13
- Side cover → 3-8
- Drive chain case → 3-19
- Rear wheel → 3-34



BRAKES

BRAKE FLUID REPLACEMENT

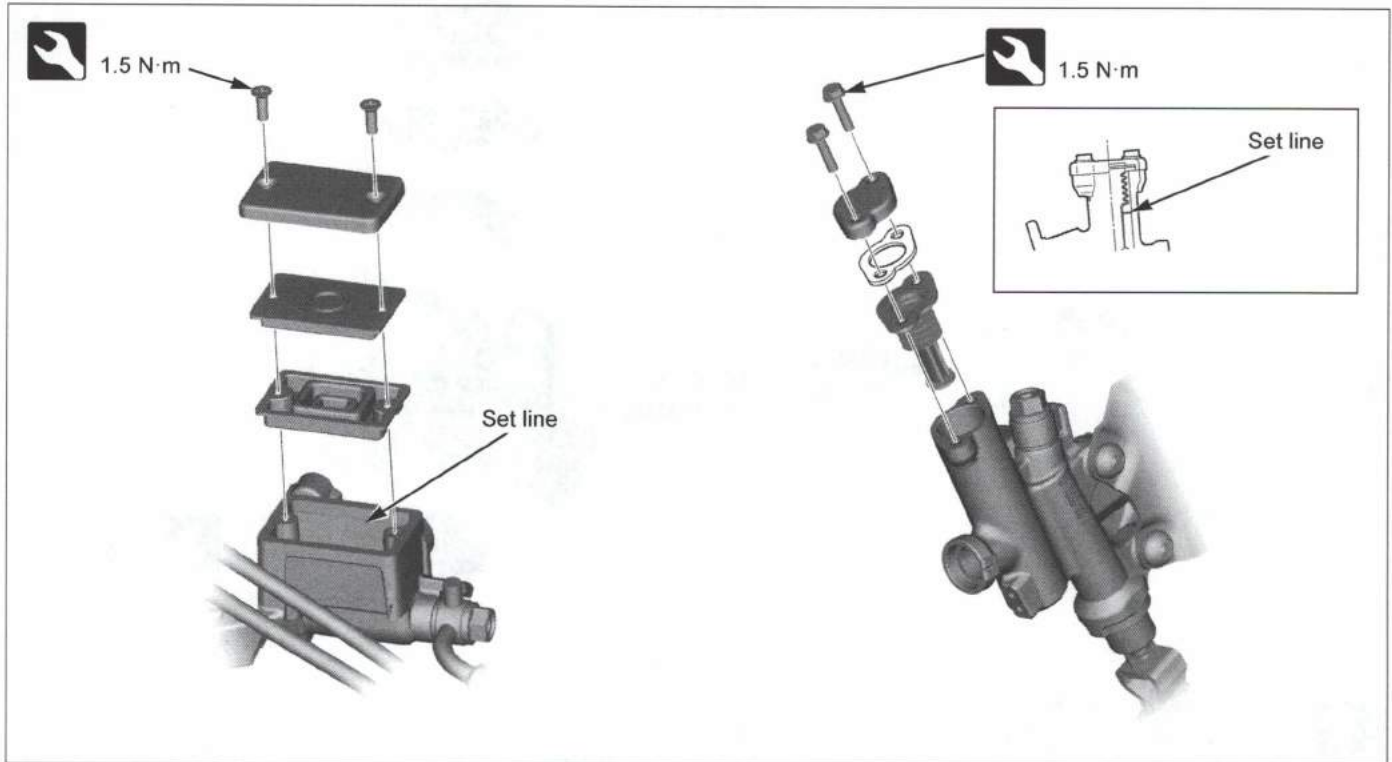

- From a sealed container, add brake fluid to the set line on the reservoir.
RECOMMENDED BRAKE FLUID: DOT 3 or 4 brake fluid

FRONT BRAKE

BRAKE MASTER CYLINDER

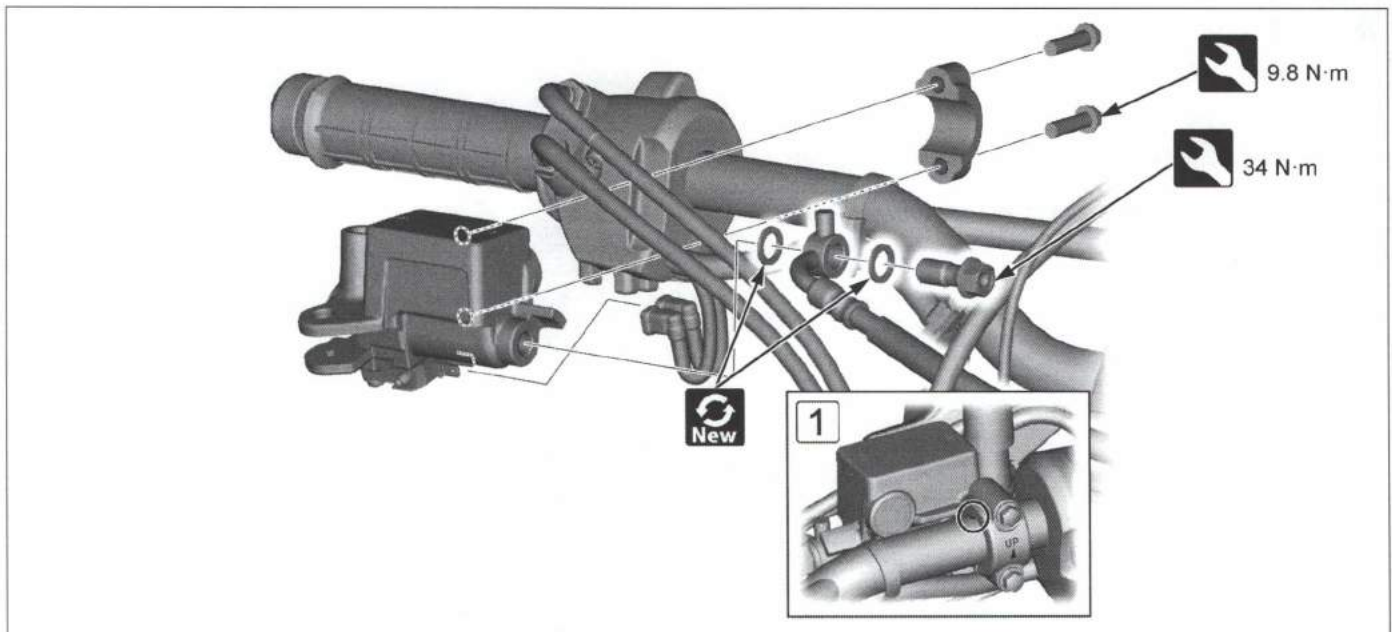

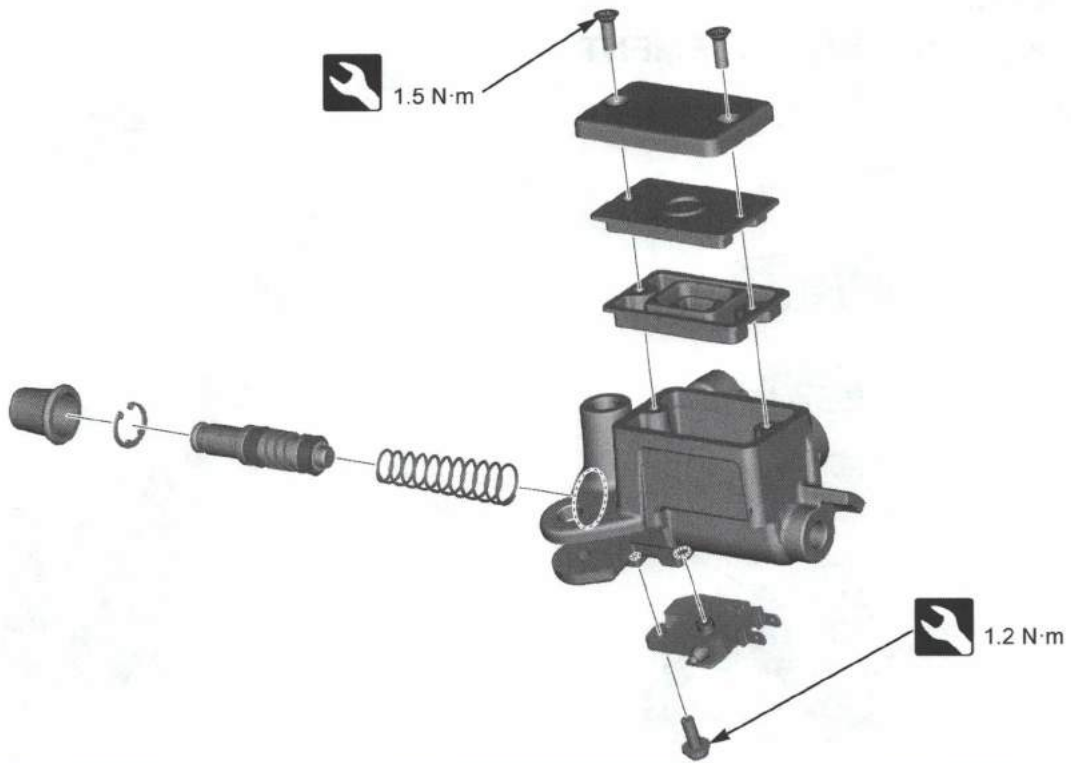

• Rearview mirror →3-4



• Knuckle guard (rally type) /brake lever →3-11



• 1 Install the holder with the "UP" mark facing up. Align the edge of the master cylinder with the punch mark.



• Remove the snap ring.

Snap ring pliers: 07914-SA50001

• Master cylinder inspection



BRAKE CALIPER

BRAKE PAD REPLACEMENT

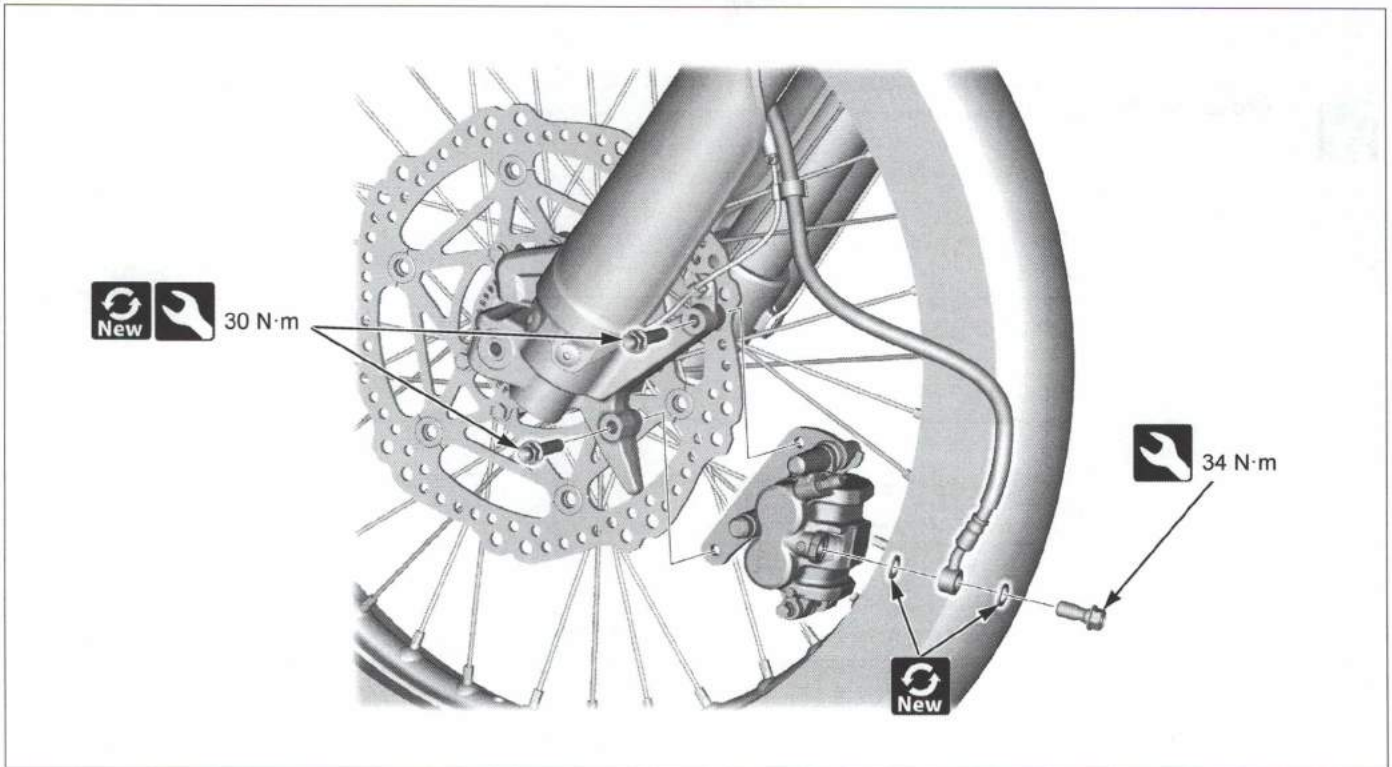
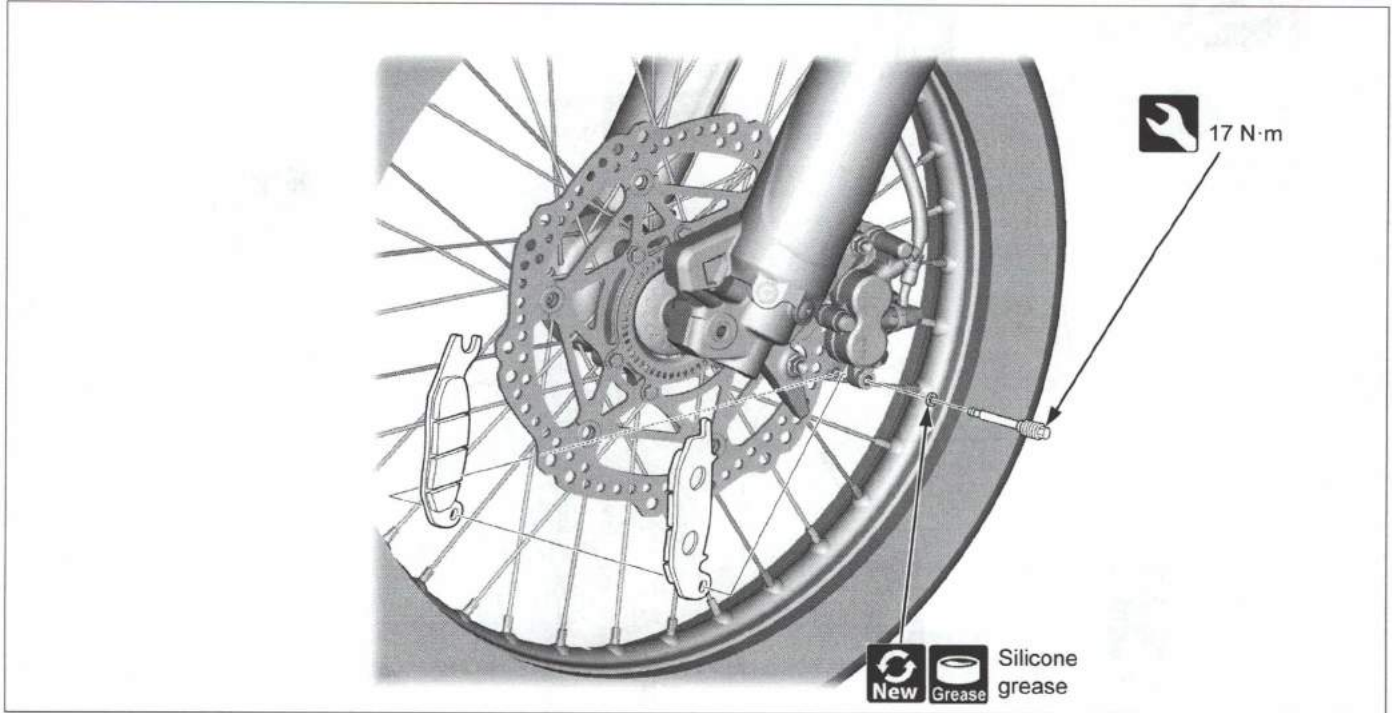



FRAME & CHASSIS

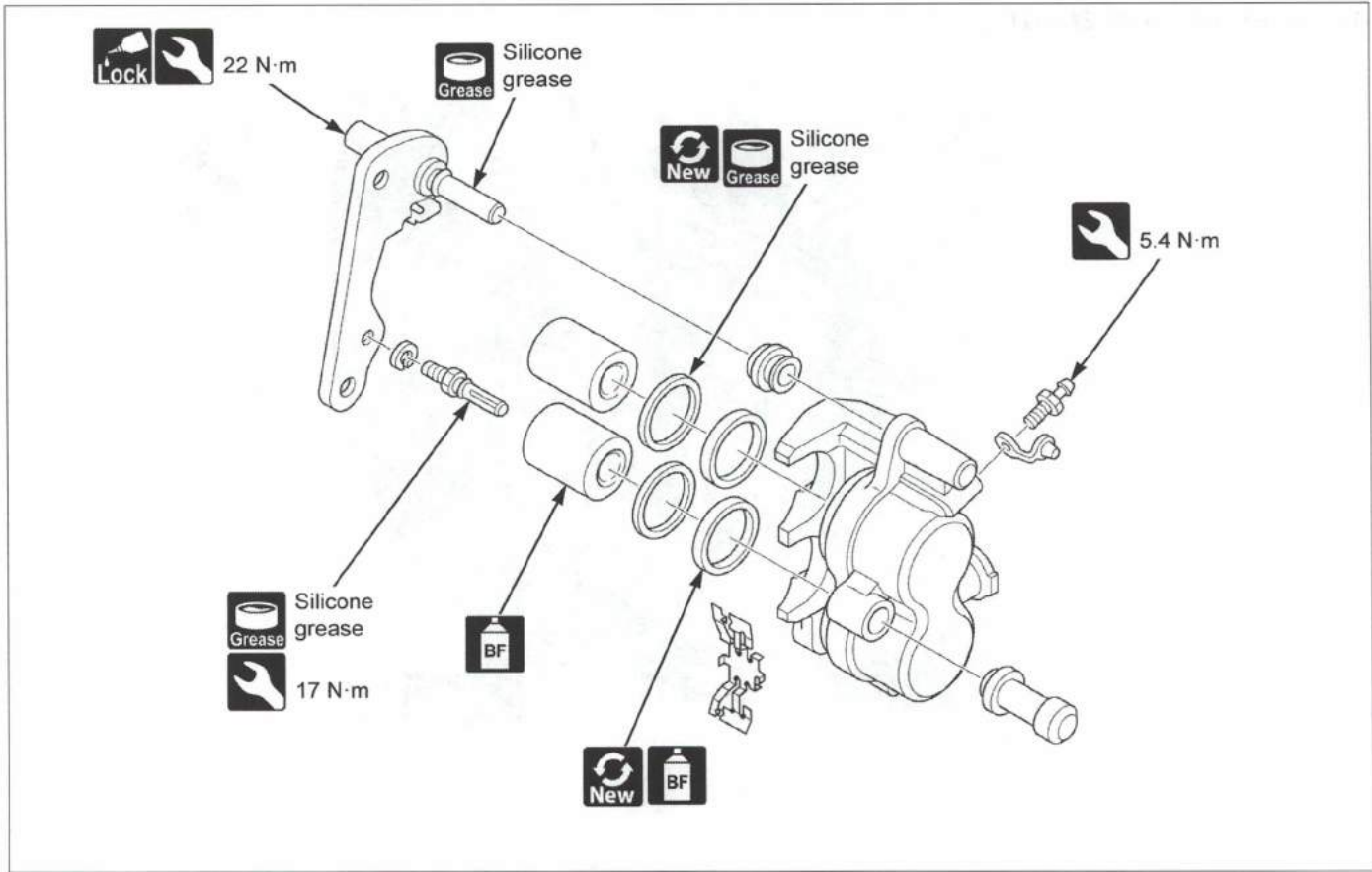

• Brake caliper inspection



REAR BRAKE BRAKE MASTER CYLINDER

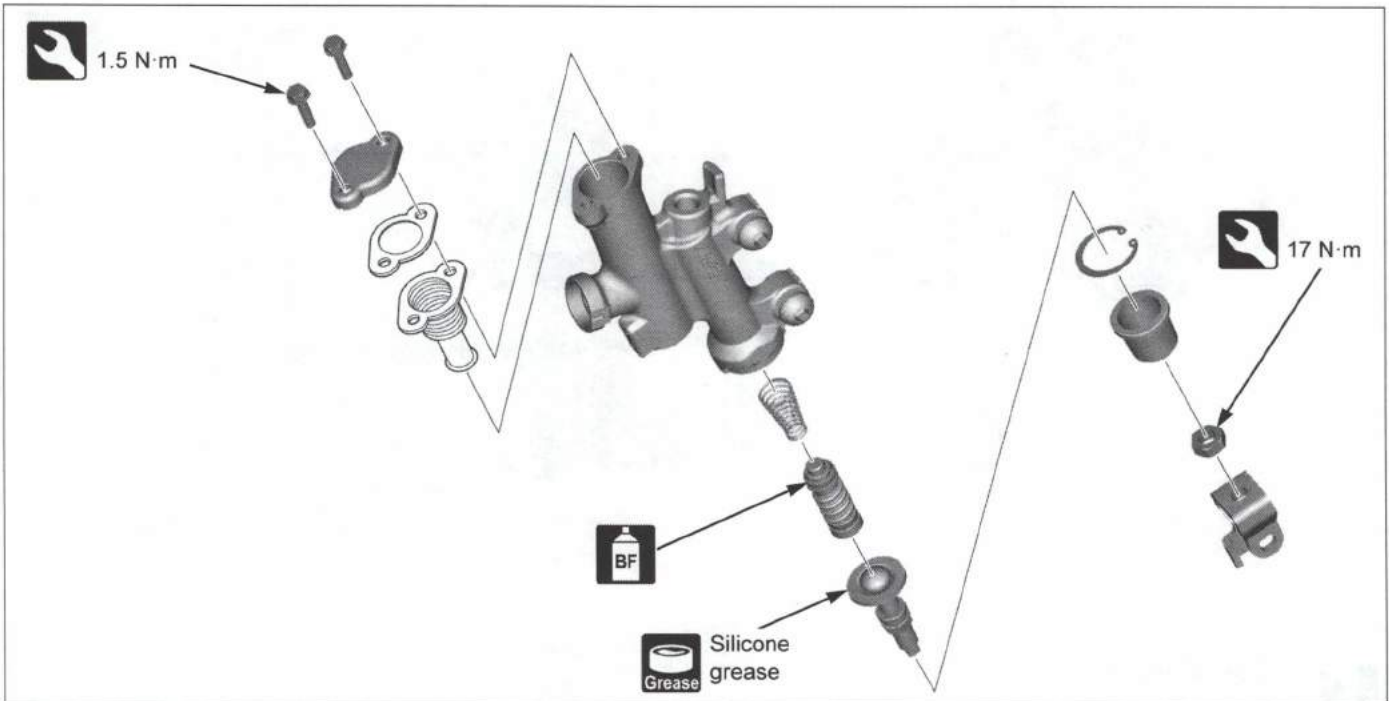
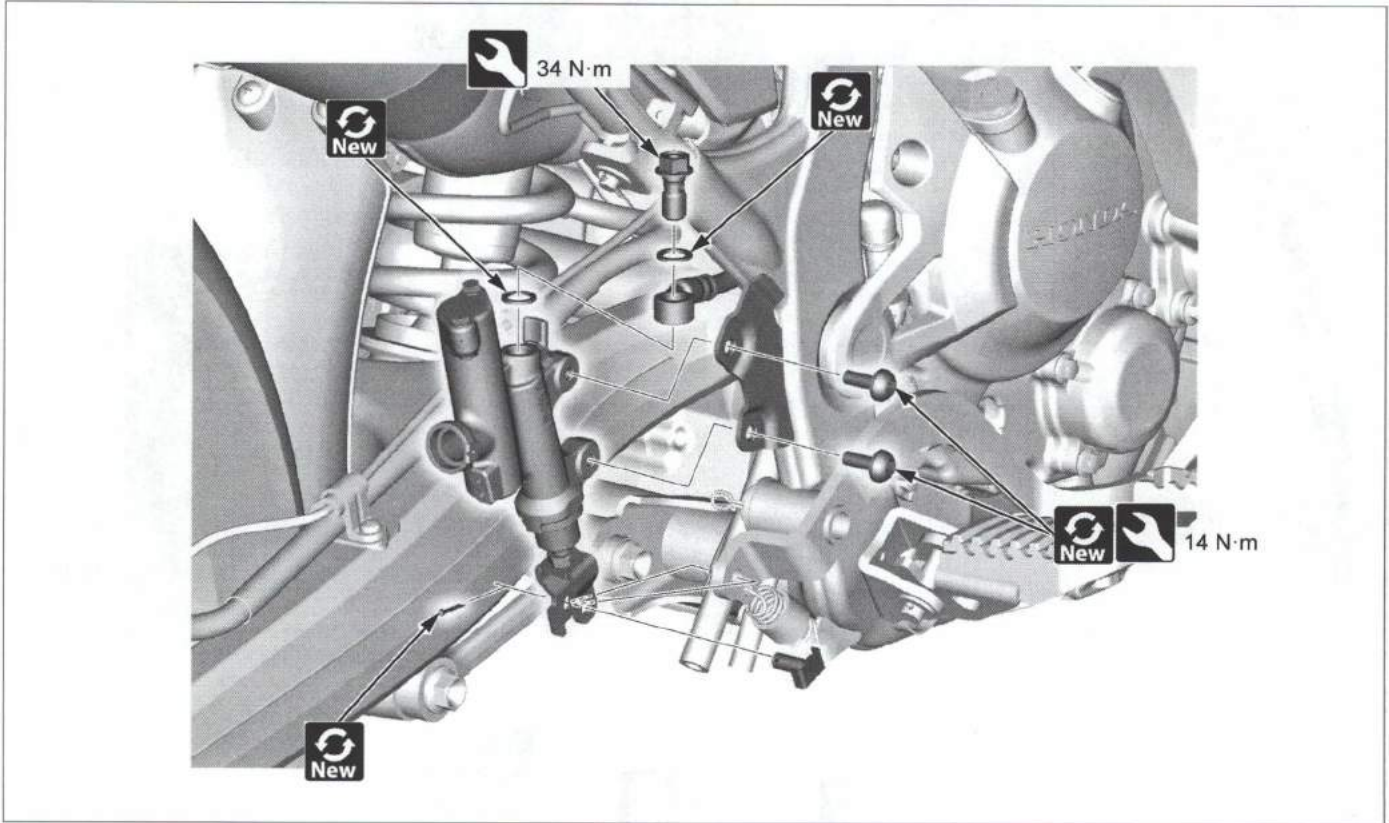

- Remove the snap ring.
Snap ring pliers: 07914-SA50001



- Master cylinder inspection



BRAKE CALIPER

BRAKE PAD REPLACEMENT

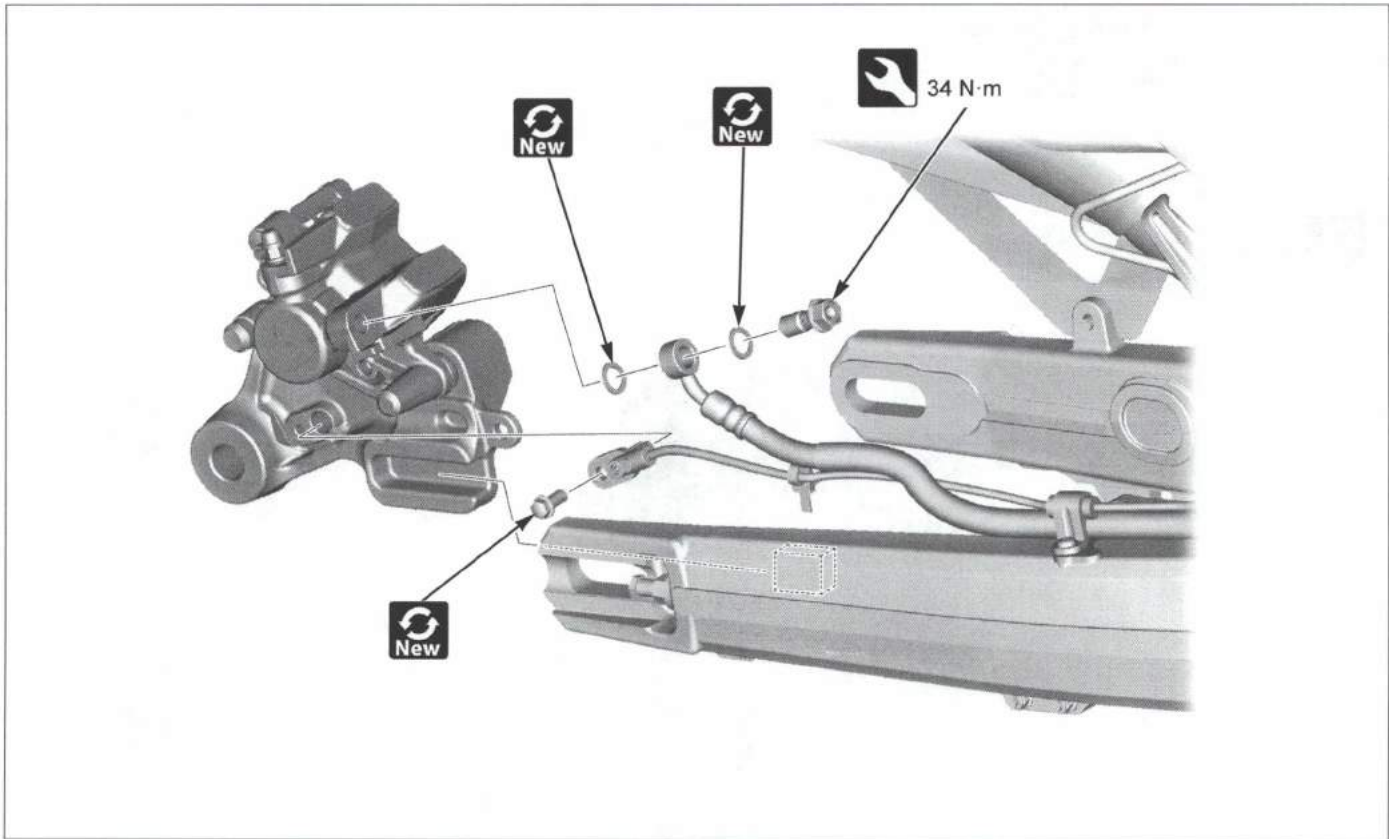
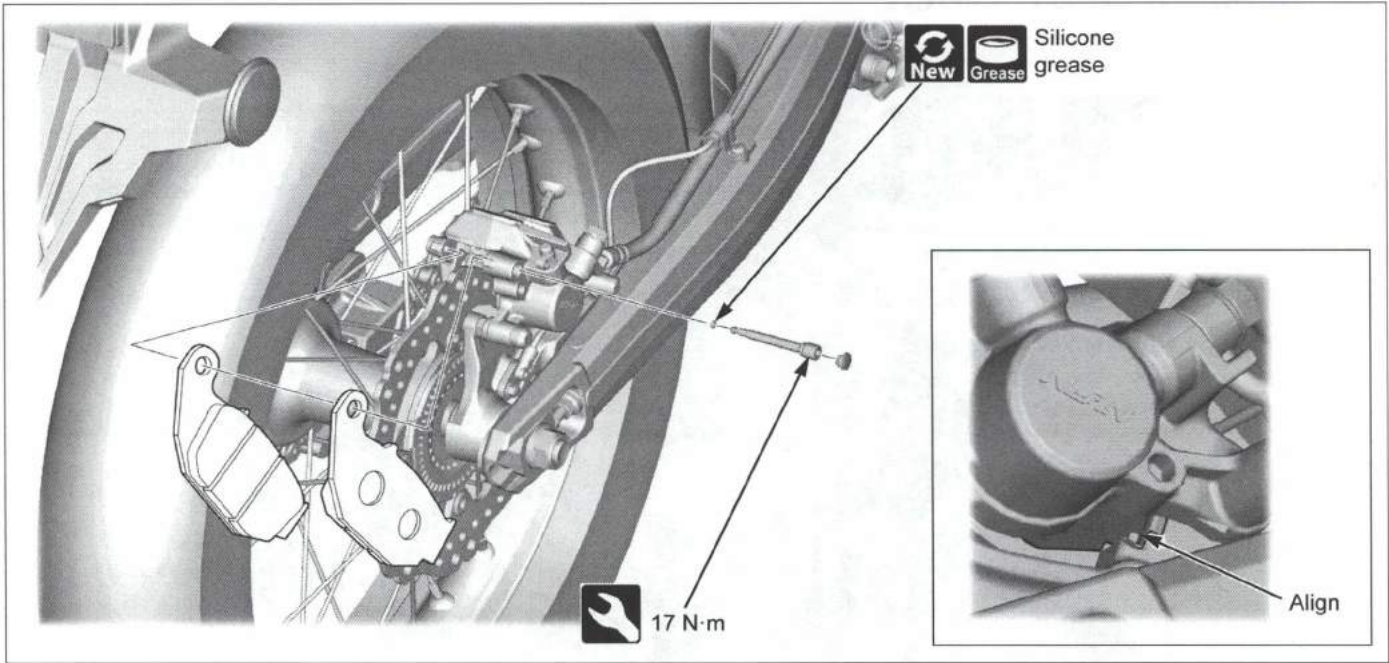

• Rear wheel → 3-34

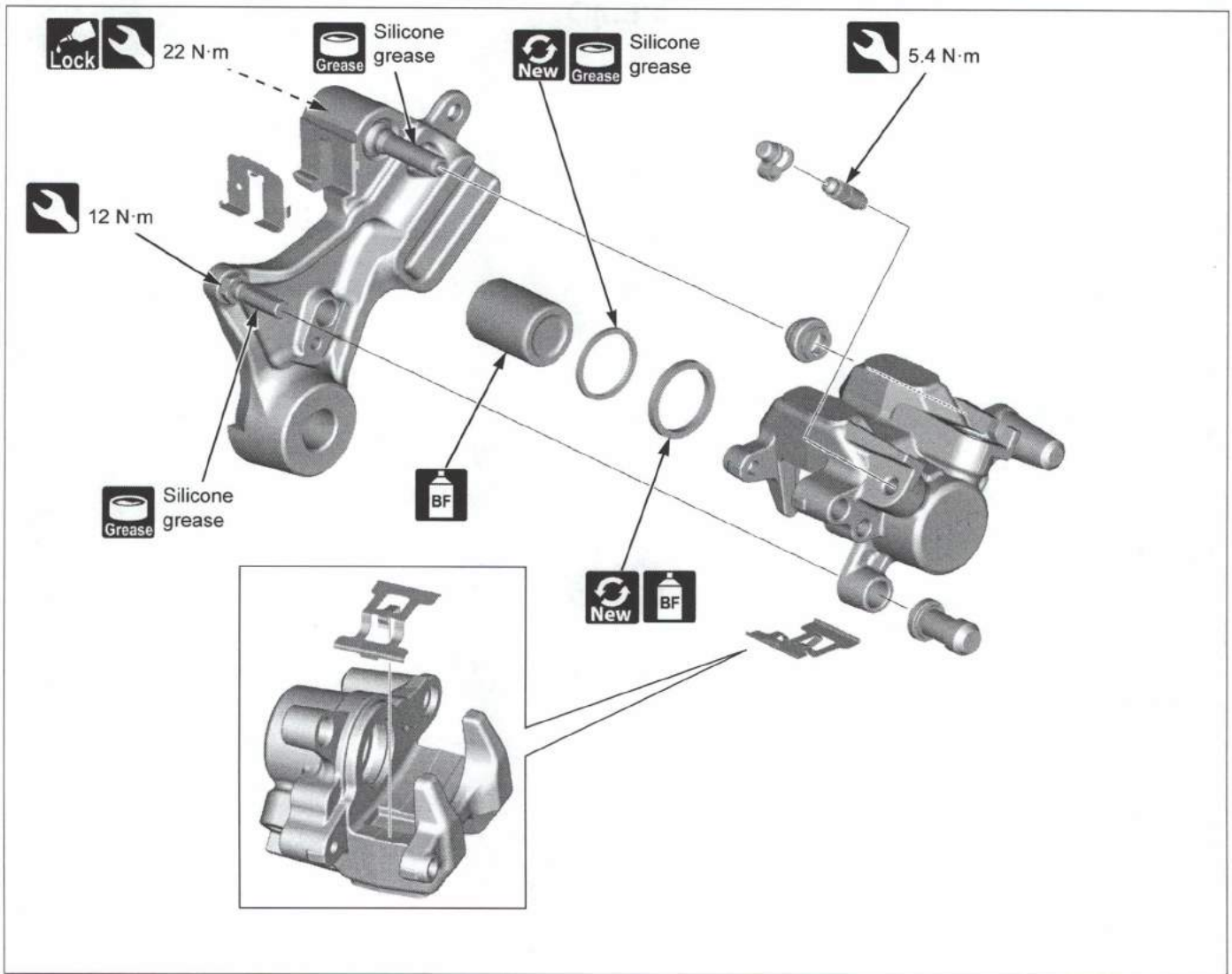

• Brake caliper inspection

MEMO

4. ELECTRICAL SYSTEM

PGM-FI SYSTEM	4-2	BATTERY/CHARGING SYSTEM	4-50
IGNITION SYSTEM	4-27	LIGHTING SYSTEM	4-52
ELECTRICAL STARTER	4-30	COMBINATION METER	4-59
ABS	4-34	ELECTRICAL COMPONENT	4-63



PGM-FI SYSTEM



- Refer to "Basic Shop manual" for the following information.
 - PGM-FI technical feature and each sensor function.
 - Symptom troubleshooting for the PGM-FI system.
 - MCS (Motorcycle Communication System) information.
- If the MCS or GST is not used, perform all of the inspection on the corresponding main code (digits in front of hyphen) of the DTC.

DTC INDEX

DTC	Function Failure	Symptom/Fail-safe function	Page
P0107 (1-1)	MAP sensor malfunction • MAP sensor low voltage	• Engine operates normally	→4-5
P0108 (1-2)	MAP sensor malfunction • MAP sensor high voltage	• Engine operates normally	→4-6
P0117 (7-1)	ECT sensor malfunction • ECT sensor low voltage	• Hard start at a low temperature	→4-7
P0118 (7-2)	ECT sensor malfunction • ECT sensor high voltage	• Hard start at a low temperature	→4-8
P0122 (8-1)	TP sensor malfunction • TP sensor low voltage	• Poor engine acceleration	→4-9
P0123 (8-2)	TP sensor malfunction • TP sensor high voltage	• Poor engine acceleration	→4-10
P0112 (9-1)	IAT sensor malfunction • IAT sensor low voltage	• Engine operates normally	→4-11
P0113 (9-2)	IAT sensor malfunction • IAT sensor high voltage	• Engine operates normally	→4-12
P0500 (11-1)	VS sensor malfunction	• Engine operates normally	→4-13
P0201 (12-1)	Injector malfunction	• Engine does not start • Injector, fuel pump and ignition coil shut down	→4-14
P0131 (21-1)	O ₂ sensor malfunction • O ₂ sensor low voltage	• Engine operates normally	→4-15
P0132 (21-2)	O ₂ sensor malfunction • O ₂ sensor high voltage	• Engine operates normally	→4-16
P0135 (23-1)	O ₂ sensor heater malfunction	• Engine operates normally	→4-17
P0511 (29-1)	IACV malfunction	• Engine stalls, hard to start, rough idling	→4-18
P062F (33-2)	ECM EEPROM malfunction	• Engine stalls, hard to start, rough idling • Does not hold the self diagnosis data • Does not erase the self diagnosis data with SCS connector	→4-19
P1000 (54-1)	Bank angle sensor malfunction • Bank angle sensor low voltage	• Engine operates normally • Engine stop function does not operate	→4-20
P1001 (54-2)	Bank angle sensor malfunction • Bank angle sensor high voltage	• Engine operates normally • Engine stop function does not operate	→4-21
P0443 (88-1)	EVAP purge control solenoid valve malfunction • Loose or poor contact of the EVAP purge control solenoid valve connector • EVAP purge control solenoid valve or its circuit malfunction	• Engine operates normally	→4-22
P0412 (89-1)	PAIR control solenoid valve malfunction	• Engine operates normally	→4-23
P0351 (91-1)	Ignition coil primary circuit malfunction • Ignition coil or its circuit malfunction	• Engine does not start • Injector and ignition coil shut down	→4-24

PGM-FI SYSTEM LOCATION

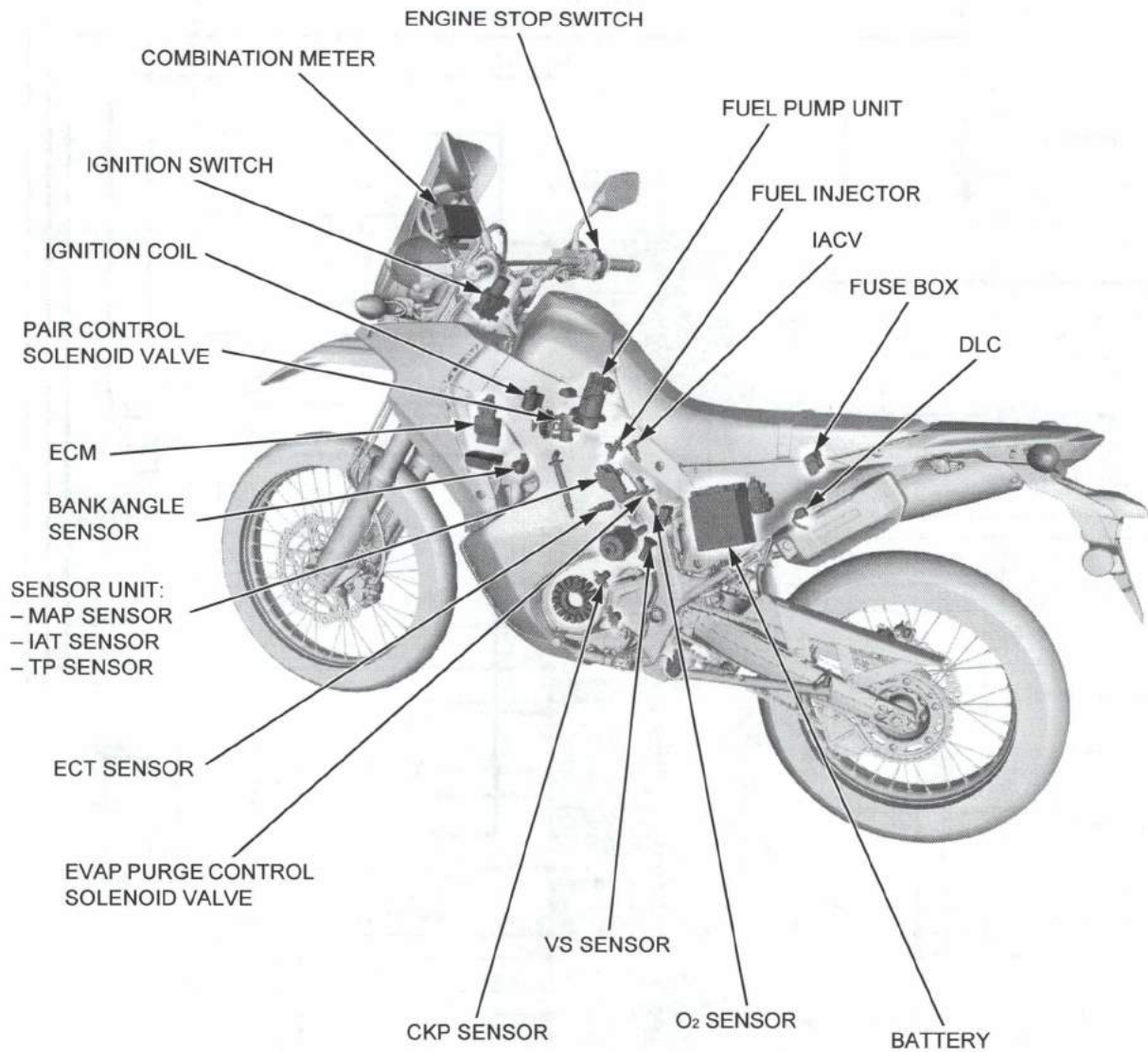



ELECTRICAL SYSTEM

PGM-FI SYSTEM DIAGRAM

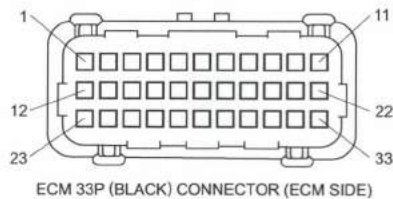
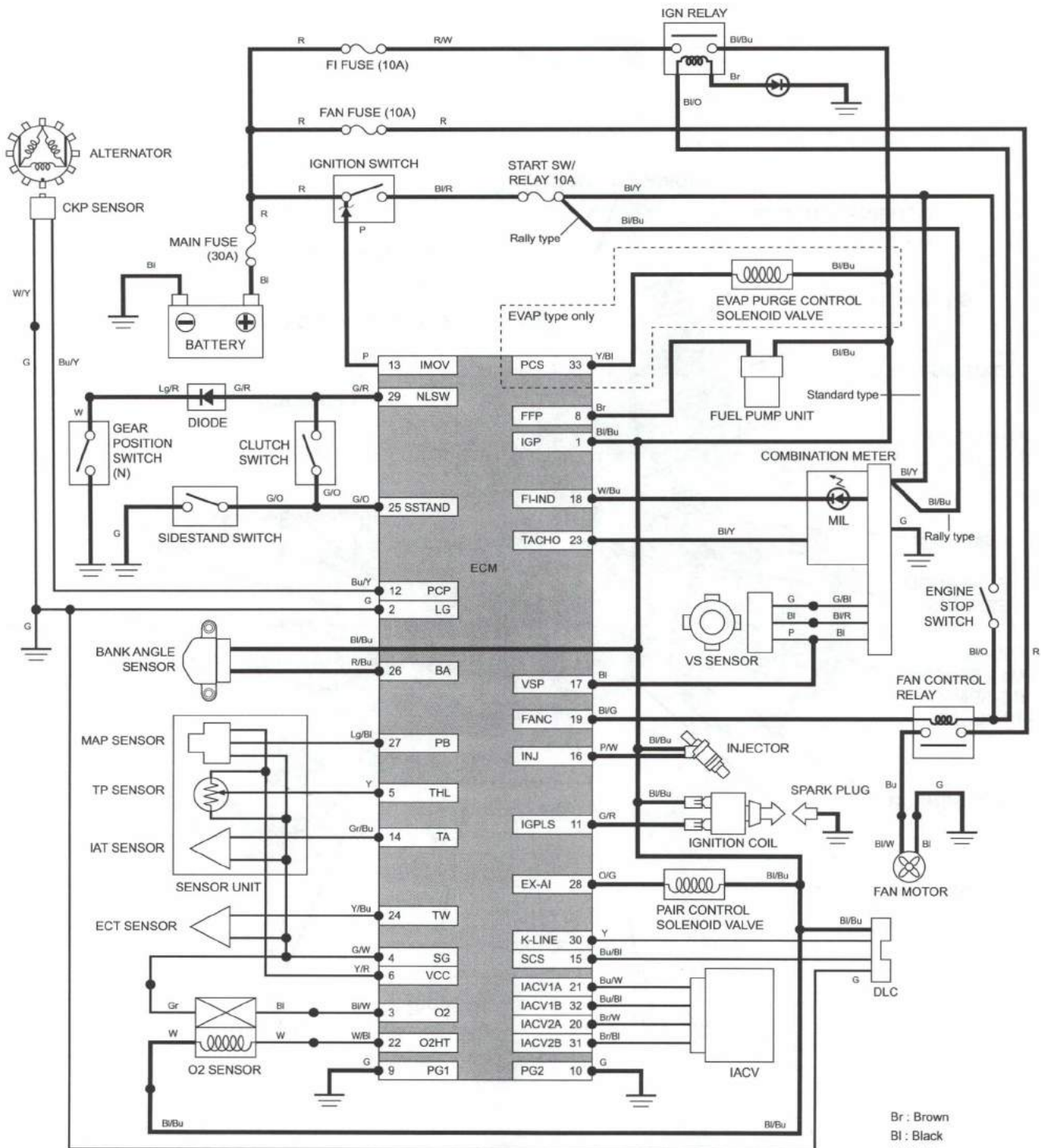

- Br : Brown
- Bl : Black
- Y : Yellow
- Bu : Blue
- G : Green
- R : Red
- W : White
- O : Orange
- Lg : Light green
- Gr : Gray
- P : Pink

DTC TROUBLESHOOTING

P0107 (MAP SENSOR LOW VOLTAGE)



• Fuel tank shroud →3-13

MAP Sensor Diagram

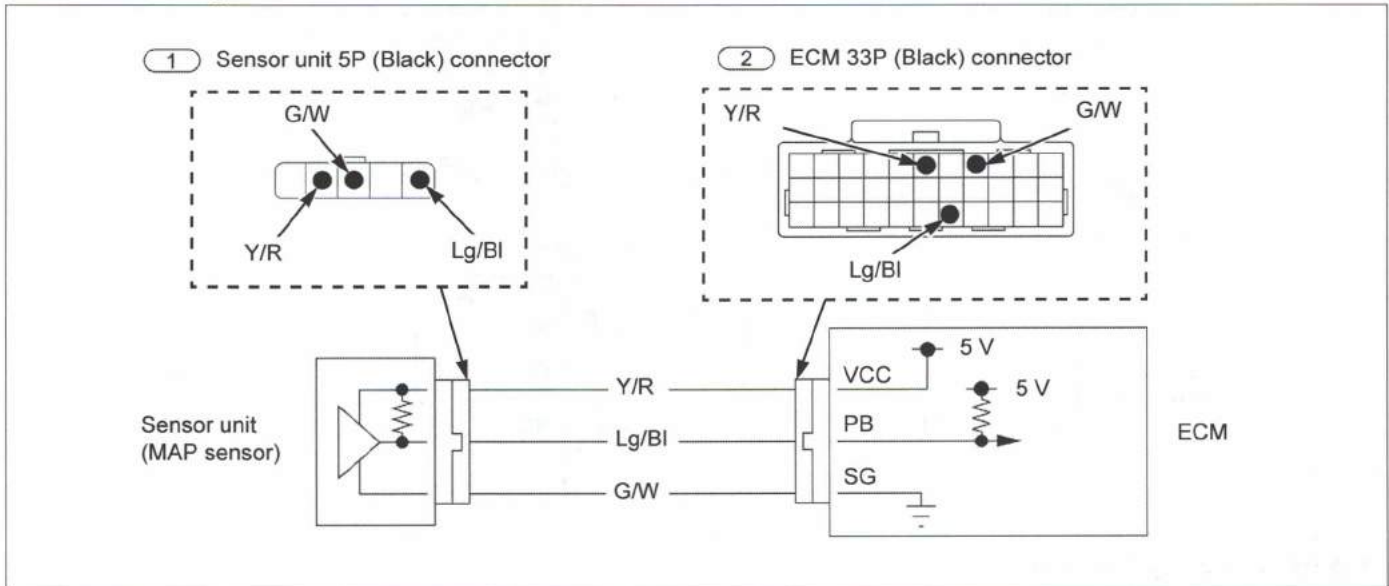

1. MAP Sensor System Inspection

- Check the MAP sensor voltage with MCS.
- Is the voltage about 0 V indicated?

Yes ▼

No

- Intermittent failure
- Loose or poor contact at the connector

2. Sensor unit Power Input Voltage Inspection



- Connection: Y/R (+) – G/W (-)
- Is the voltage within 4.75 – 5.25 V?

Yes ▼

No

- Open or short circuit in Y/R wire
- If there is no open or short circuit, replace the ECM with a new one →4-25, and recheck.

3. MAP Sensor Output Voltage Inspection



- Connection: Lg/BI (+) – G/W (-)
- Is the voltage within 3.80 – 5.25 V?

No ▼

Yes

- Replace the sensor unit (MAP sensor) with a new one →2-8, and recheck.

4. MAP Sensor Output Line Inspection

- Check for a short circuit in Lg/BI wire.
- If there is no short circuit, replace the ECM with a new one →4-25, and recheck.



ELECTRICAL SYSTEM

P0108 (MAP SENSOR HIGH VOLTAGE)



• Fuel tank shroud →3-13

MAP Sensor Diagram

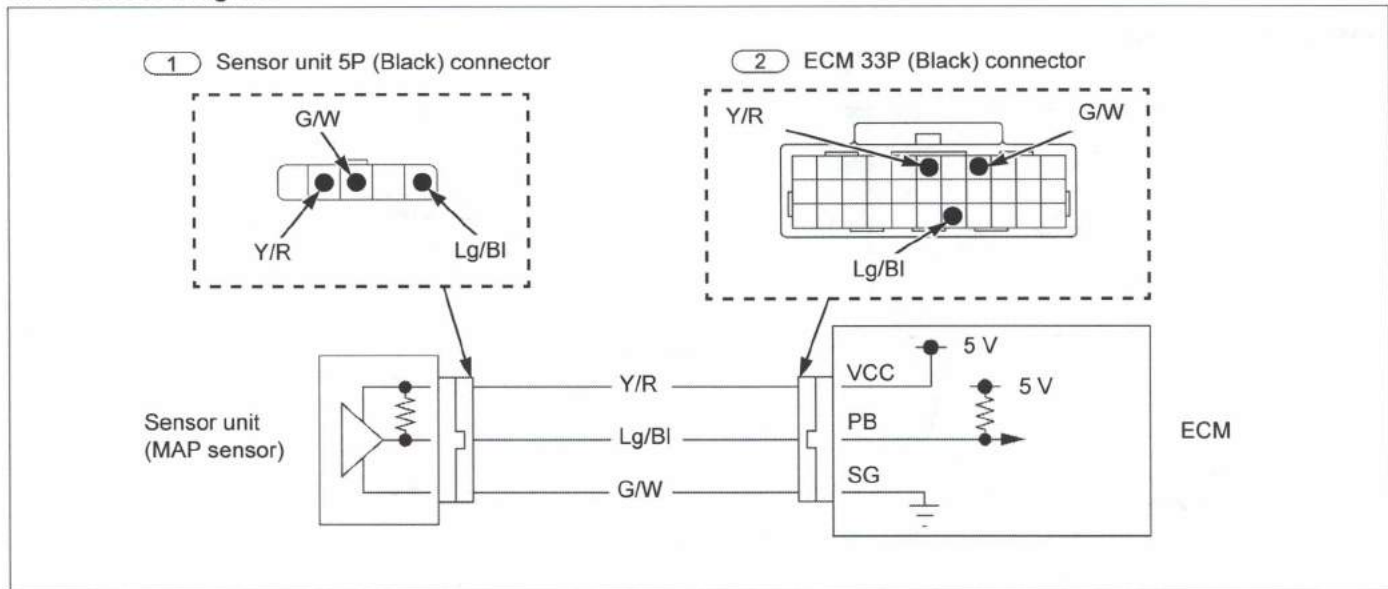

1. MAP Sensor System Inspection

- Check the MAP sensor voltage with MCS.
- Is the voltage about 5 V indicated?

No ▶

- Intermittent failure
- Loose or poor contact at the connector

Yes ▼

2. MAP Sensor Inspection



1

- Install a jumper wire between the terminals. Connection: Lg/BI – G/W
- Check the MAP sensor voltage with MCS.
- Is the voltage about 0 V indicated?

Yes ▶

- Replace the sensor unit (MAP sensor) with a new one →2-8, and recheck.

No ▼

3. MAP Sensor Output Line Inspection

- Check for an open circuit in Lg/BI and G/W wire.
- If there is no open circuit, replace the ECM with a new one →4-25, and recheck.

P0117 (ECT SENSOR LOW VOLTAGE)



- Fuel tank shroud →3-13

ECT Sensor Diagram

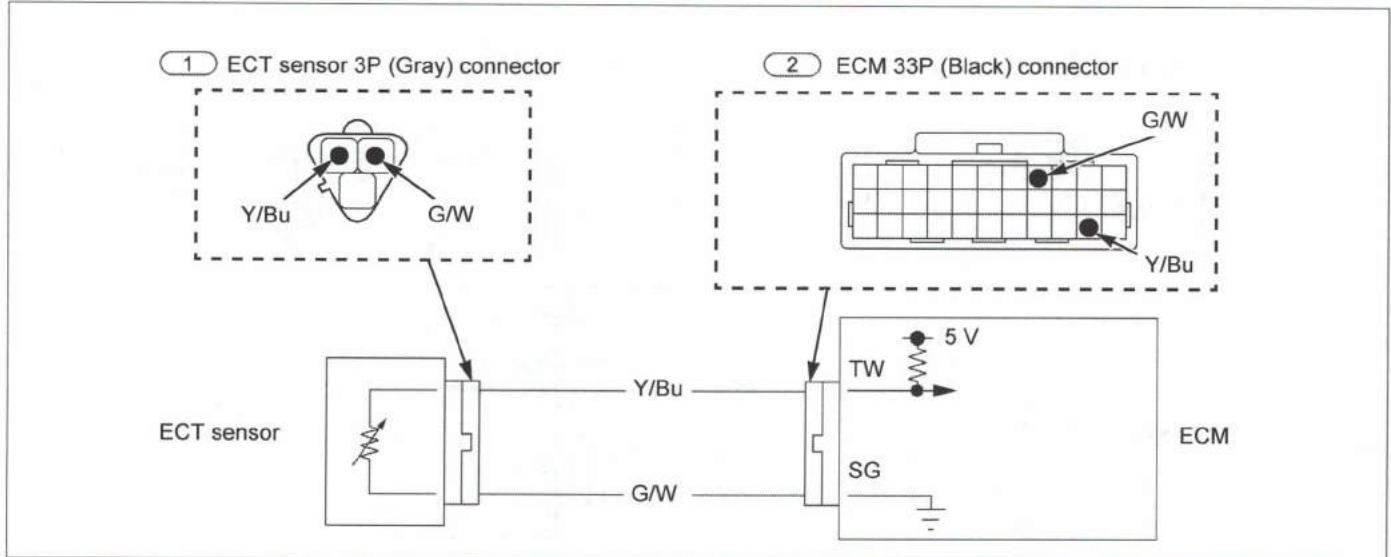

1. ECT Sensor System Inspection

- Check the ECT sensor voltage with MCS.
- Is the voltage about 0 V indicated?

Yes ▼

No

- Intermittent failure
- Loose or poor contact at the connector

2. ECT Sensor Inspection

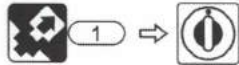

- Check the ECT sensor voltage with MCS.
- Is the voltage about 0 V indicated?

Yes ▼

No

- Replace the ECT sensor with a new one →4-25, and recheck.

3. ECT Sensor Output Line Inspection

- Check for a short circuit in Y/Bu wire.
- If there is no short circuit, replace the ECM with a new one →4-25, and recheck.



ELECTRICAL SYSTEM

P0118 (ECT SENSOR HIGH VOLTAGE)



• Fuel tank shroud →3-13

ECT Sensor Diagram

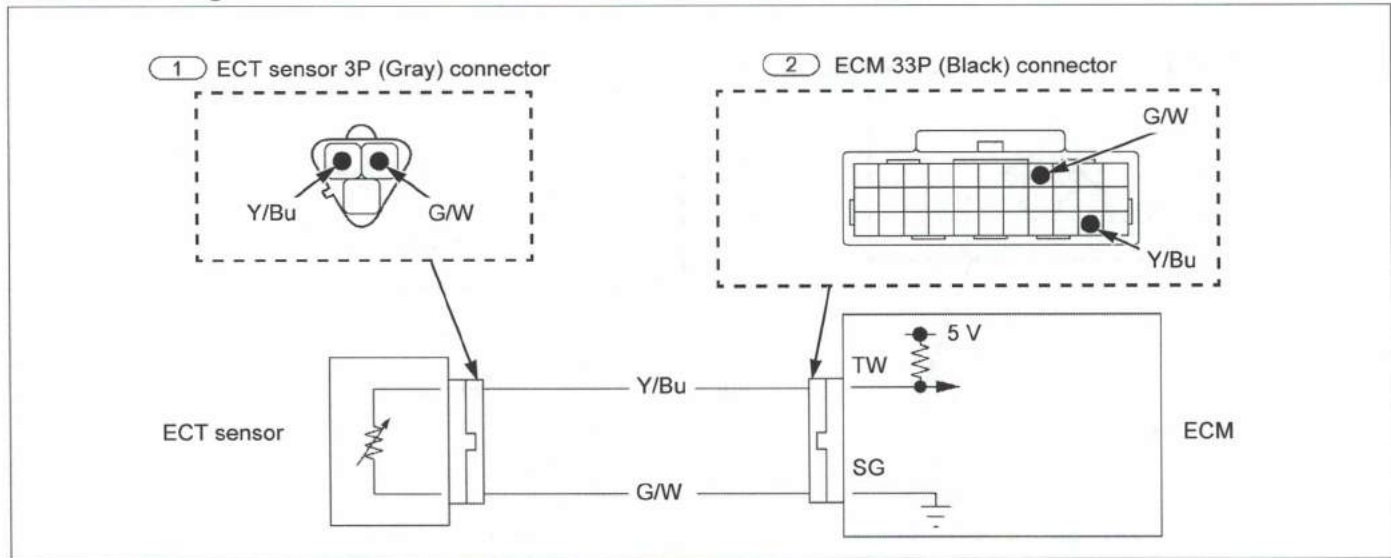

1. ECT Sensor System Inspection

- Check the ECT sensor voltage with MCS.
- Is the voltage about 5 V indicated?

Yes ▼

No ►

- Intermittent failure
- Loose or poor contact at the connector

2. ECT Sensor Inspection

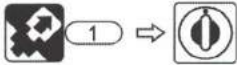

- Install a jumper wire between the terminals.
Connection: Y/Bu – G/W
- Check the ECT sensor voltage with MCS.
- Is the voltage about 0 V indicated?

No ▼

Yes ►

- Replace the ECT sensor with a new one →4-25, and recheck.

3. ECT Sensor Output Line Inspection

- Check for an open circuit in Y/Bu and G/W wire.
- If there is no open circuit, replace the ECM with a new one →4-25, and recheck.

P0122 (TP SENSOR LOW VOLTAGE)



• Fuel tank shroud →3-13

TP Sensor Diagram

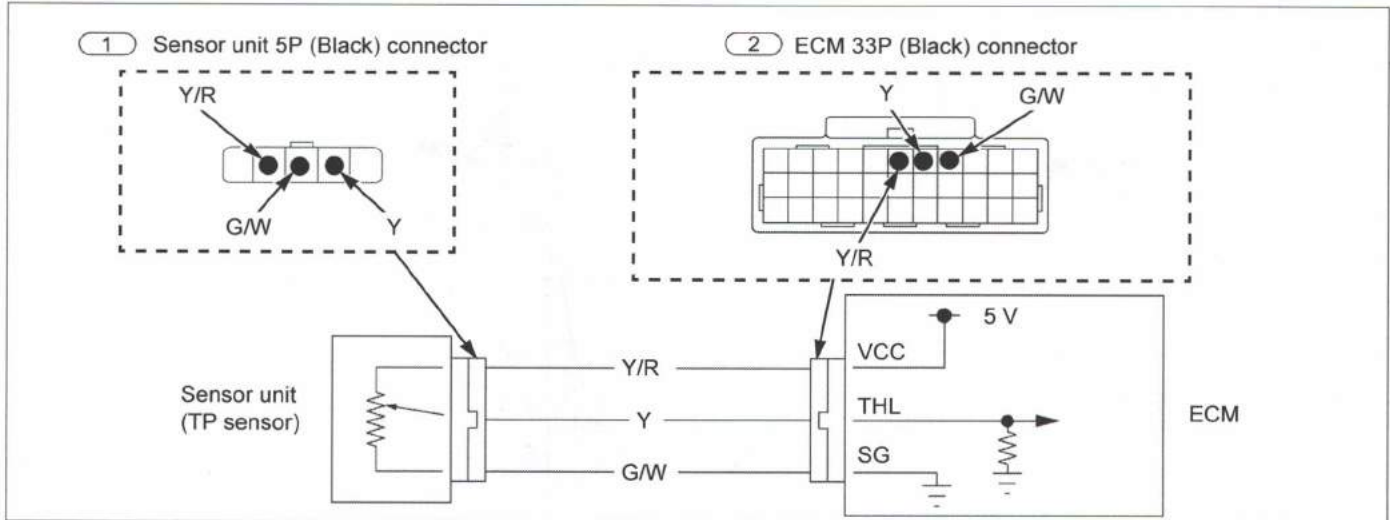

1. TP Sensor System Inspection

- Check the TP sensor voltage with MCS.
- Is the voltage about 0 V indicated?

Yes ▼

No
▶

- Intermittent failure
- Loose or poor contact at the connector

2. Sensor unit Power Input Voltage Inspection



- Connection: Y/R (+) – G/W (-)
- Is the voltage within 4.75 – 5.25 V?

Yes ▼

No
▶

- Open or short circuit in Y/R wire
- If there is no open or short circuit, replace the ECM with a new one →4-25, and recheck.

3. TP Sensor Output Line Inspection

- Check for an open or short circuit in Y wire.
- Is there open or short circuit?

No ▼

Yes
▶

- Faulty Y wire

4. TP Sensor Inspection

- Replace the sensor unit (TP sensor) with a new one →2-8
- Erase the DTC.
- Check the TP sensor with MCS.
- If DTC 8-1 is indicated, replace the ECM with a new one →4-25, and recheck.



ELECTRICAL SYSTEM

P0123 (TP SENSOR HIGH VOLTAGE)



• Fuel tank shroud →3-13

TP Sensor Diagram

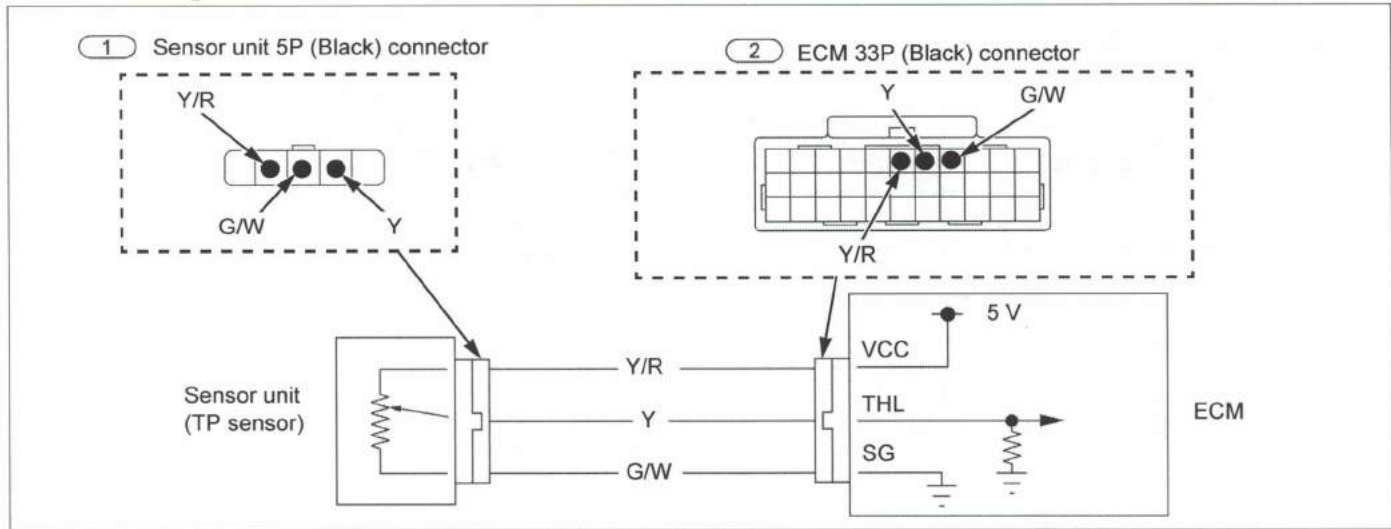

1. TP Sensor System Inspection

- Check the TP sensor voltage with MCS when the throttle fully closed.
- Is the voltage about 5 V indicated?

Yes ▼

No ►

- Check the TP sensor voltage with MCS.
- Operate the throttle from fully closed to fully opened.
- If the voltage is not increase continuously, replace the sensor unit (TP sensor) with a new one →2-8, and recheck.

2. TP Sensor Ground Line Inspection

- Check for an open circuit in G/W wire.
- Is there open circuit?

No ▼

Yes ►

- Faulty G/W wire

3. TP Sensor Inspection

- Replace the sensor unit (TP sensor) with a new one →2-8
- Erase the DTC.
- Check the TP sensor with MCS.
- If DTC 8-2 is indicated, replace the ECM with a new one →4-25, and recheck.

P0112 (IAT SENSOR LOW VOLTAGE)



- Fuel tank shroud → 3-13

IAT Sensor Diagram

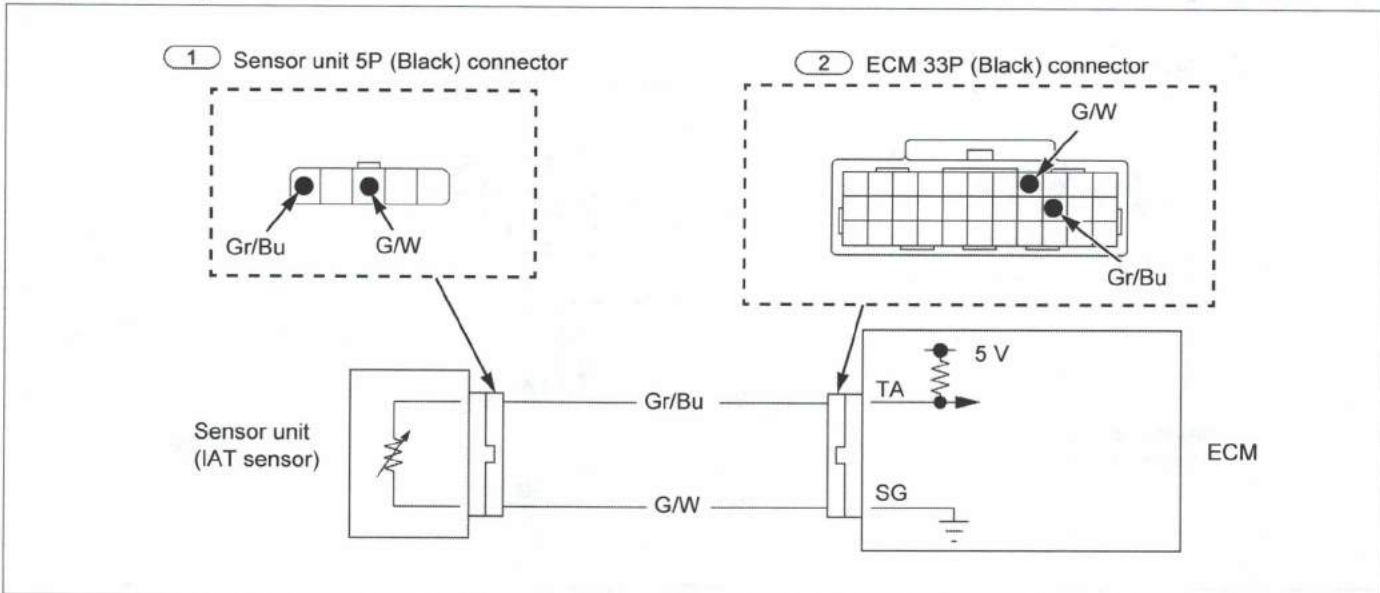

1. IAT Sensor System Inspection

- Check the IAT sensor voltage with MCS.
- Is the voltage about 0 V indicated?

Yes ▼

No

- Intermittent failure
- Loose or poor contact at the connector

2. IAT Sensor Inspection

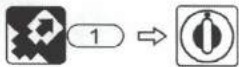

- Check the IAT sensor voltage with MCS.
- Is the voltage about 0 V indicated?

Yes ▼

No

- Replace the sensor unit (IAT sensor) with a new one → 2-8, and recheck.

3. IAT Sensor Output Line Inspection

- Check for a short circuit in Gr/Bu wire.
- If there is no short circuit, replace the ECM with a new one → 4-25, and recheck.



ELECTRICAL SYSTEM

P0113 (IAT SENSOR HIGH VOLTAGE)



• Fuel tank shroud →3-13

IAT Sensor Diagram

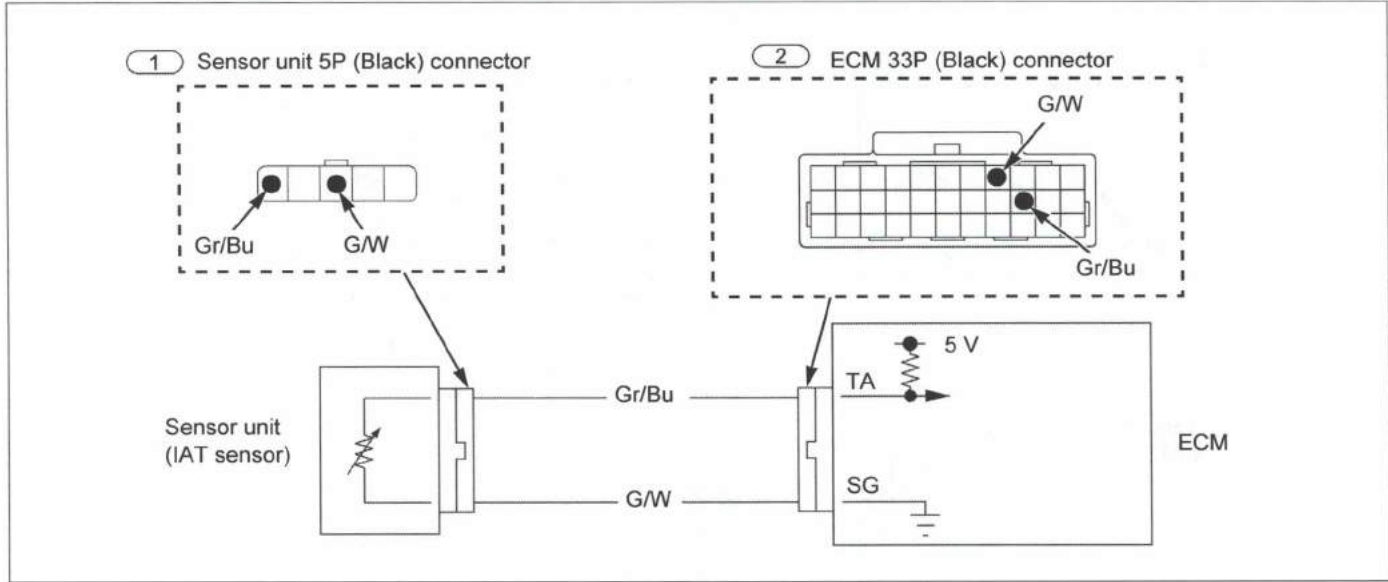

1. IAT Sensor System Inspection

- Check the IAT sensor voltage with MCS.
- Is the voltage about 5 V indicated?

Yes ▼

No

- Intermittent failure
- Loose or poor contact at the connector

2. IAT sensor Inspection

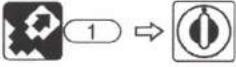

- Install a jumper wire between the terminals.
Connection: Gr/Bu – G/W
- Check the IAT sensor voltage with MCS.
- Is the voltage about 0 V indicated?

No ▼

Yes

- Replace the sensor unit (IAT sensor) with a new one →2-8, and recheck.

3. IAT Sensor Voltage Input Line Inspection

- Check for an open circuit in Gr/Bu and G/W wire.
- If there is no open circuit, replace the ECM with a new one →4-25, and recheck.

P0500 (VS SENSOR)



- Rally type: Wind screen →3-5
- Standard type: Front visor →3-6
- Fuel tank shroud →3-13

VS Sensor Diagram

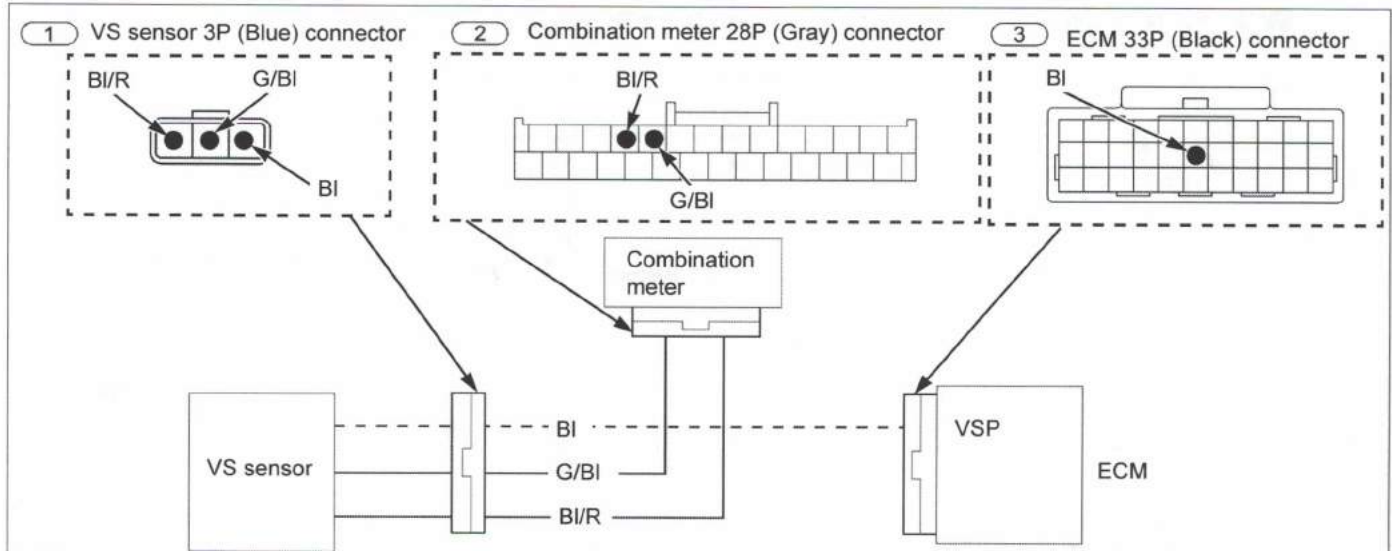

1. VS Sensor System Inspection

- Check the VS sensor with MCS.
- Is the DTC 11-1 indicated?

Yes ▼

No
▶

- Intermittent failure
- Loose or poor contact at the connector

2. VS Sensor Input Voltage Inspection



- Connection: BI/R (+) – G/BI (–)
- Does the battery voltage exist?

Yes ▼

No
▶

- Faulty BI/R or G/BI wire

3. VS Sensor Signal Line Inspection

- Check for an open or short circuit in BI wire.
- Is there open or short circuit?

No ▼

Yes
▶

- Faulty BI wire

4. VS Sensor Inspection

- Replace the VS sensor with a new one. →4-61
- Erase the DTC's.
- Test-ride the vehicle and check the VS sensor with MCS.
- If DTC 11-1 is indicated, replace the combination meter with a new one →4-59, and recheck.
- Erase the DTC's.
- Test-ride the vehicle and check the VS sensor with MCS.
- If DTC 11-1 is indicated, replace the ECM with a new one →4-25, and recheck.



ELECTRICAL SYSTEM

P0201 (INJECTOR)



• Fuel tank shroud →3-13

Injector Diagram

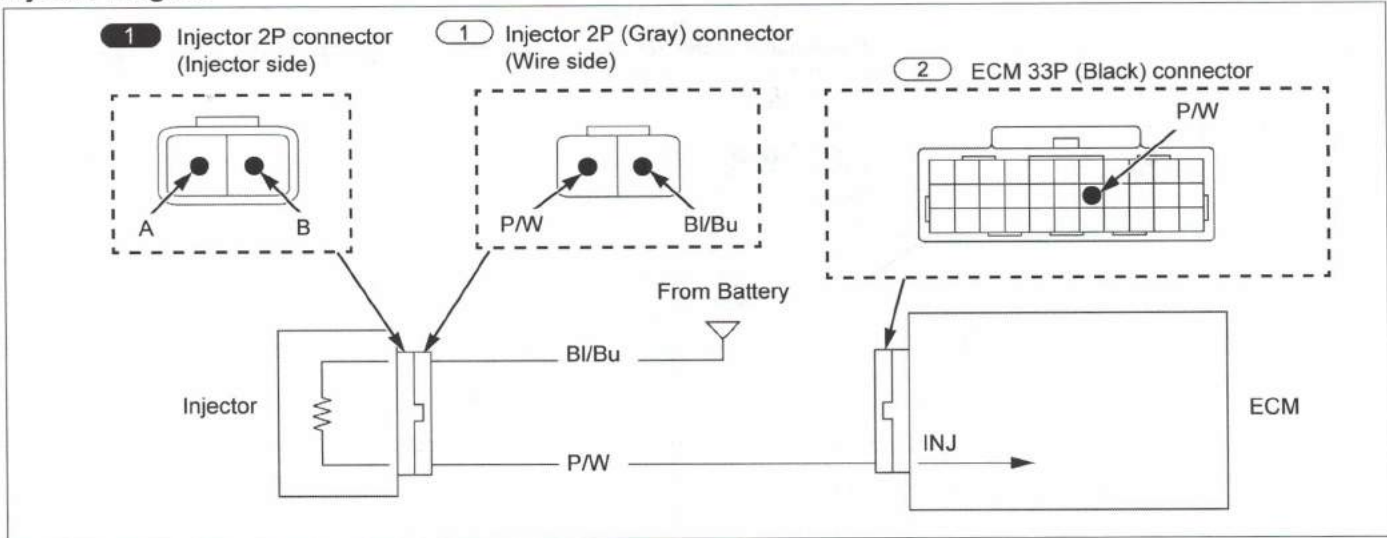

1. Fuel Injector System Inspection

- Check the fuel injector with MCS.
- Is the DTC 12-1 is indicated?

Yes ▼

No ►

- Intermittent failure
- Loose or poor contact at the connector

2. Fuel Injector Input Voltage Inspection



- Connection: BI/Bu (+) – Ground (-)
- Does the battery voltage exist?

Yes ▼

No ►

- Open circuit in BI/Bu wire

3. Fuel Injector Signal Line Inspection

- Check for an open or short circuit in P/W wire.
- Is there open or short circuit?

No ▼

Yes ►

- Faulty P/W wire

4. Fuel Injector Resistance inspection



- Connection: A – B
- Is the resistance within 11 – 13 Ω (20°C)?

Yes ▼

No ►

- Faulty fuel injector

- Replace the ECM with a new one →4-25, and re-check.



P0131 (O₂ SENSOR LOW VOLTAGE)



• Fuel tank shroud →3-13

O₂ Sensor Diagram

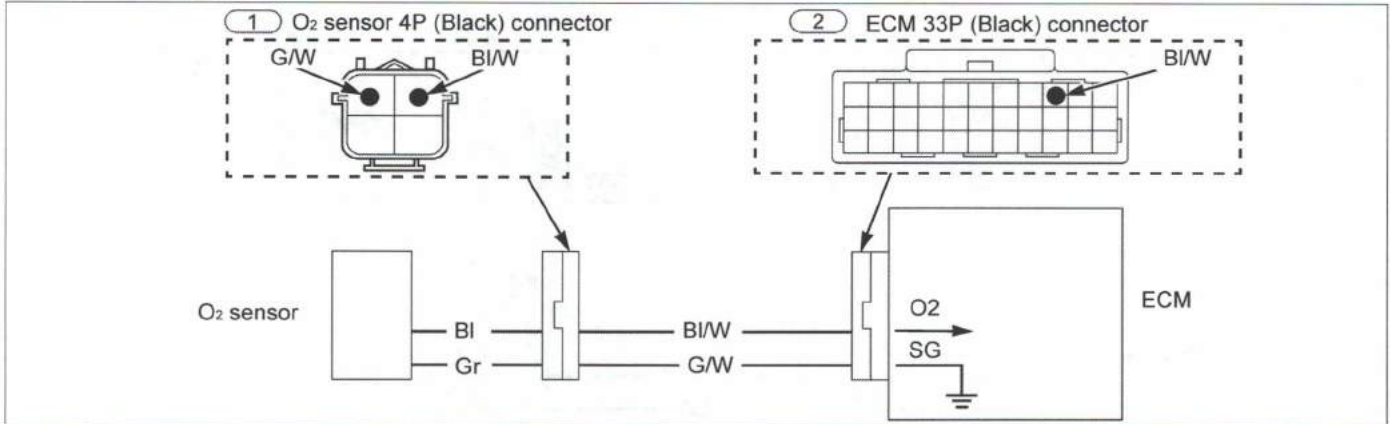

1. O₂ Sensor System Inspection

- Test-ride the vehicle and check the O₂ sensor with MCS.
- Is the DTC 21-1 indicated?

Yes ▼

No
▶

- Intermittent failure
- Loose or poor contact at the connector

2. O₂ Sensor Circuit Inspection

- Check for a short circuit in BI/W wire.
- Are there short circuit?

No ▼

Yes
▶

- Faulty BI/W wire.

3. Fuel Supply Test (Fuel Pressure Test)

- Perform the fuel pressure test. →2-3
- Is the fuel pressure within specification?

Yes ▼

No
▶

- Check that there is any erratic swing or vibration of the gauge needle in the pressure gauge reading.
 - If the needle is swing or vibration, replace the fuel filter. →2-5
 - If the needle is stable, replace the fuel pump unit. →2-4

4. Fuel Supply Test (Fuel Flow Test)

- Adjust the fuel in the tank until the fuel gauge segment is positioned the specified range, and inspect the fuel flow. →2-3
- Is the fuel flow within specification?

Yes ▼

No
▶

- Replace the fuel filter. →2-5

5. O₂ Sensor Inspection

- Replace the O₂ sensor with a new one. →4-26
- Erase the DTC's.
- Test-ride the vehicle and check the O₂ sensor with MCS.
- If DTC 21-1 is indicated, replace the ECM with a new one →4-25, and recheck.



ELECTRICAL SYSTEM

P0132 (O₂ SENSOR HIGH VOLTAGE)



- Fuel tank shroud →3-13

O₂ Sensor Diagram

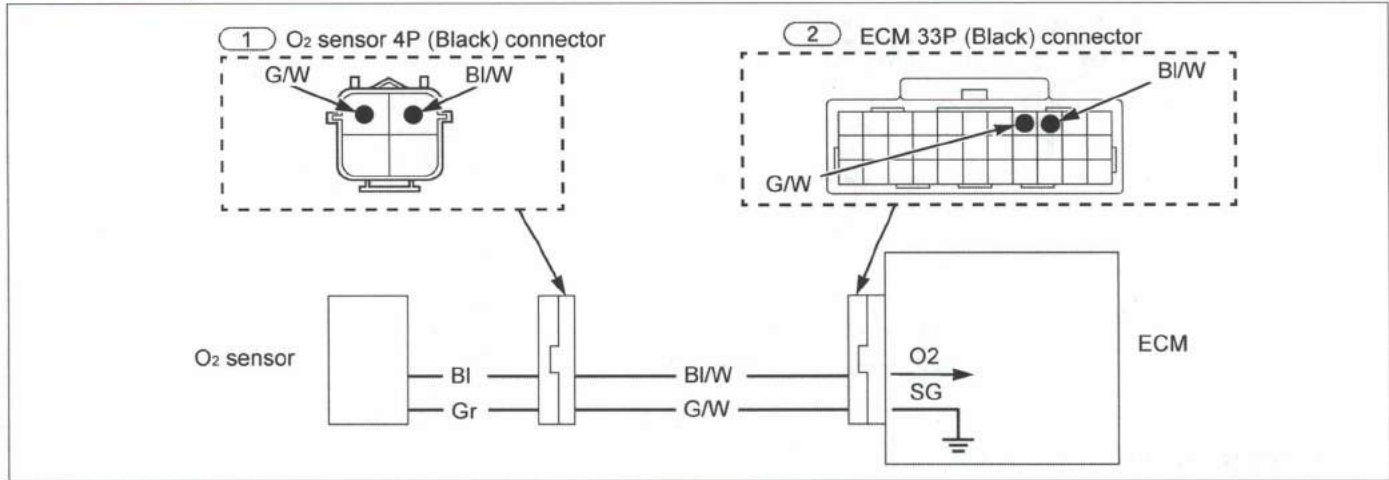

1. O₂ Sensor System Inspection

- Test-ride the vehicle and check the O₂ sensor with MCS.
- Is the DTC 21-2 indicated?

Yes ▼

No ►

- Intermittent failure
- Loose or poor contact at the connector

2. O₂ Sensor Circuit Inspection

- Check for open circuit in BI/W and G/W wires.
- Are there open circuit?

No ▼

Yes ►

- Faulty BI/W or G/W wire.

3. O₂ Sensor Inspection

- Replace the O₂ sensor with a new one. →4-26
- Erase the DTC's.
- Test-ride the vehicle and check the O₂ sensor with MCS.
- If DTC 21-2 is indicated, replace the ECM with a new one →4-25, and recheck.



P0135 (O₂ SENSOR HEATER)



• Fuel tank shroud →3-13

O₂ Sensor Heater Diagram

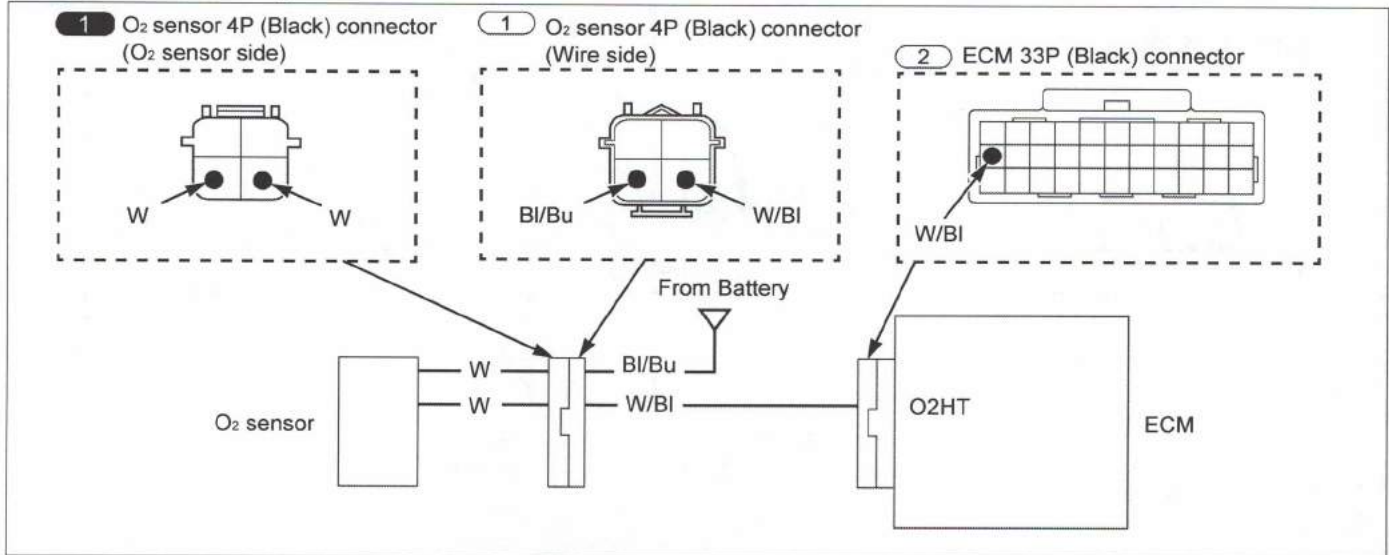

1. O₂ Sensor Heater System Inspection

- Erase the DTC's, and check the O₂ sensor heater with MCS.
- Is the DTC 23-1 indicated?

Yes ▼

No
▶

- Intermittent failure
- Loose or poor contact at the connector

2. O₂ Sensor Heater Input Voltage Inspection

-
- Connection: BI/Bu (+) – Ground (-)
 - Does the battery voltage exist?

Yes ▼

No
▶

- Faulty BI/Bu wire

3. O₂ Sensor Heater Signal Line Inspection

- Check for an open or short circuit in W/BI wire.
- Is there open or short circuit?

No ▼

Yes
▶

- Faulty W/BI wire

3. O₂ Sensor Heater Resistance Inspection

-
- Connection: W – W
 - Is the resistance within 13 – 19 Ω (20 °C)?

Yes ▼

No
▶

- Faulty O₂ sensor

- Replace the ECM with a new one →4-25, and recheck.



ELECTRICAL SYSTEM

P0511 (IACV)



• Fuel tank shroud →3-13

IACV Diagram

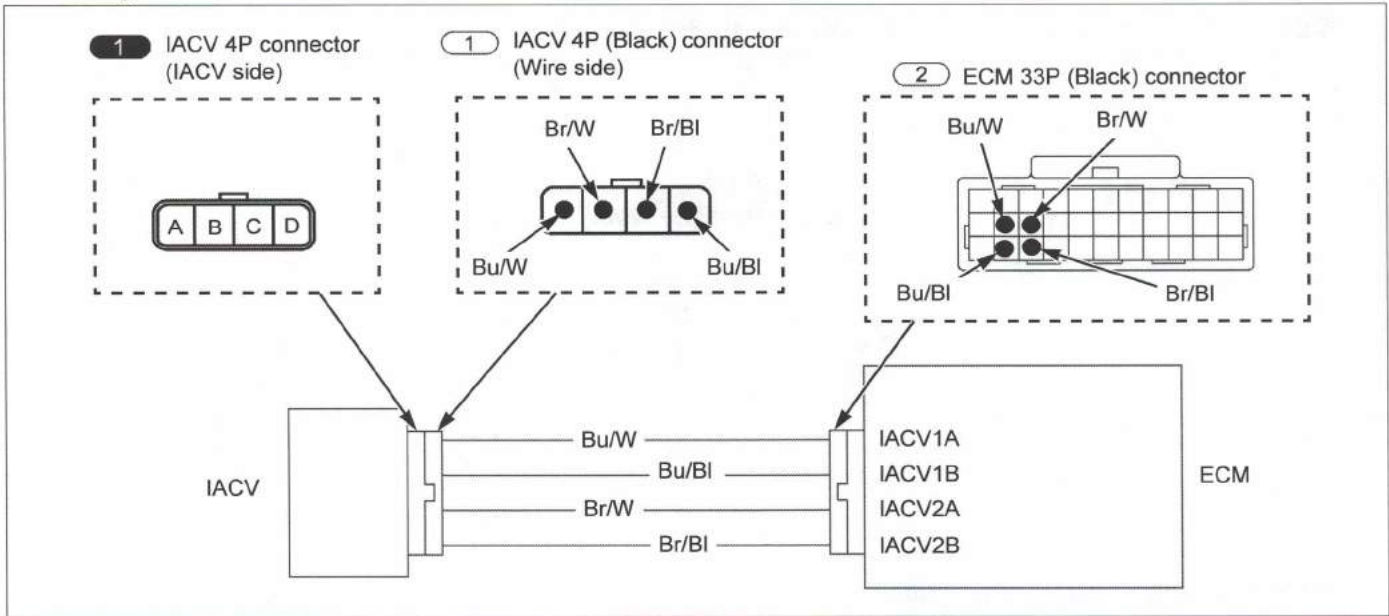

1. IACV System Inspection

- Check the IACV with MCS.
- Is the DTC 29-1 is indicated?

Yes ▼

No ►

- Intermittent failure
- Loose or poor contact at the connector

2. IACV Circuit Inspection

- Check for an open or short circuit in Bu/W, Br/W, Br/Bl and Bu/Bl wires.
- Is there open or short circuit?

No ▼

Yes ►

- Faulty Bu/W, Br/W, Br/Bl or Bu/Bl wire

3. IACV Resistance Inspection



- Connection: A – D, B – C
- Is the resistance within 110 – 150 Ω (25°C)?

Yes ▼

No ►

- Faulty IACV

4. IACV Short Circuit Inspection

- Connection: A – B, C – D
- Is there continuity?

No ▼

Yes ►

- Faulty IACV

- Replace the ECM with a new one →4-25, and re-check.

**P062F (EEPROM)****1. EEPROM System Inspection**

- Check the EEPROM with MCS.
- Is the DTC 33-2 is indicated?

Yes ▼

- Replace the ECM with a new one →4-25, and re-check.

No
▶

- Intermittent failure
- Loose or poor contact at the connector



ELECTRICAL SYSTEM

P1000 (BANK ANGLE SENSOR LOW VOLTAGE)



• Fuel tank shroud →3-13

Bank Angle Sensor Diagram

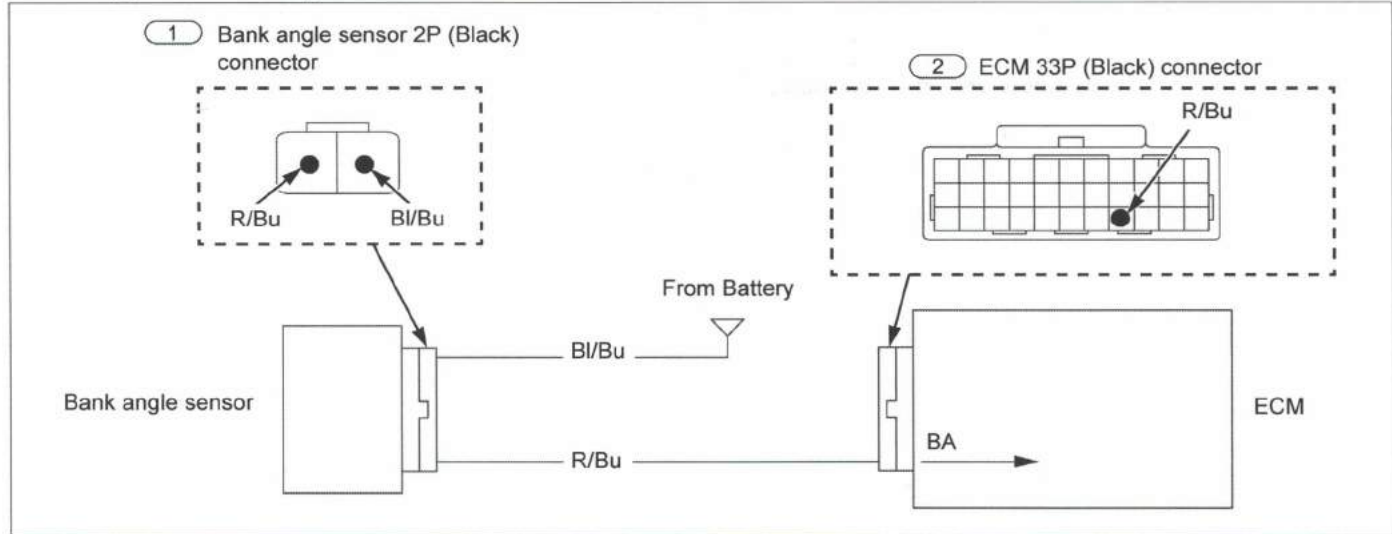

1. Bank Angle Sensor System Inspection

- Check the bank angle sensor voltage with MCS.
- Is the voltage about 0 V indicated?

Yes ▼

No ►

- Intermittent failure
- Loose or poor contact at the connector

2. Bank Angle Sensor Power Input Voltage Inspection



- Connection: Bl/Bu (+) – Ground (–)
- Does the battery voltage exist?

Yes ▼

No ►

- Faulty Bl/Bu wire

3. Bank Angle Sensor Output Line Inspection

- Check for an open or short circuit in R/Bu wire.
- Is there open or short circuit?

No ▼

Yes ►

- Faulty R/Bu wire

4. Bank Angle Sensor Inspection

- Replace the bank angle sensor with a new one. →4-26
- Erase the DTC's.
- Check the bank angle sensor with MCS.
- If DTC 54-1 is indicated, replace the ECM with a new one →4-25, and recheck.

P1001 (BANK ANGLE SENSOR HIGH VOLTAGE)

- Bank angle sensor (Connector is connected.) →4-26

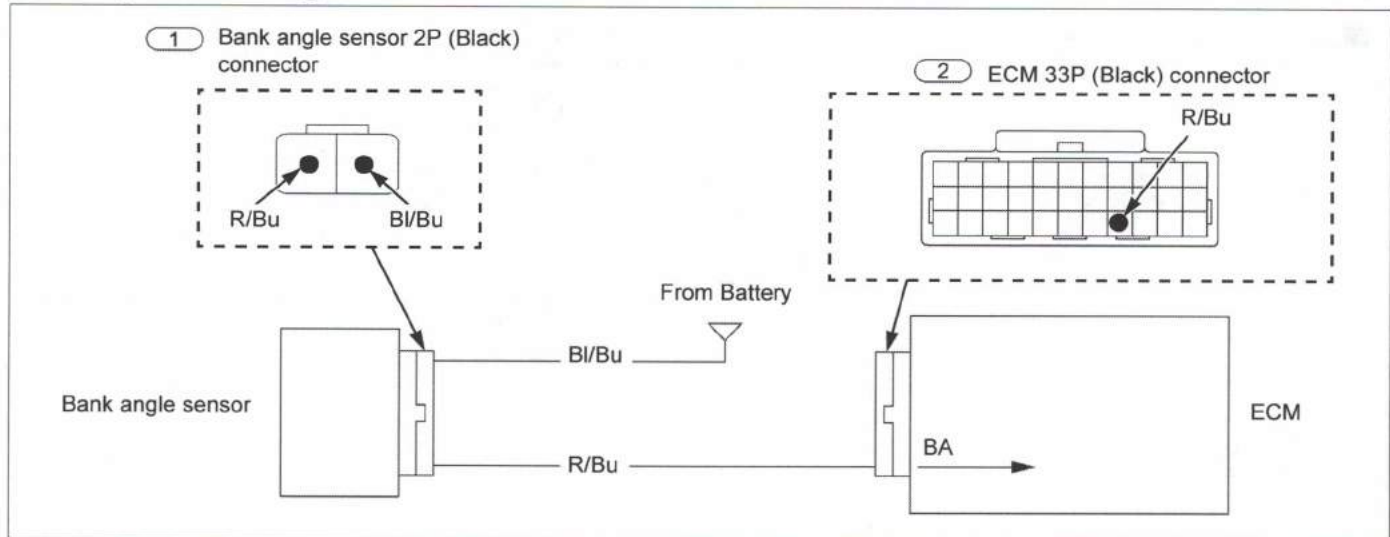
Bank Angle Sensor Diagram**1. Bank Angle Sensor System Inspection**

- Check the bank angle sensor voltage with MCS.
- Incline the bank angle sensor.
- Is the voltage decrease?

Yes
▶

- Replace the ECM with a new one →4-25, and recheck.

No ▼

- Replace the bank angle sensor with a new one →4-26, and recheck.



ELECTRICAL SYSTEM

P0443 (EVAP PURGE CONTROL SOLENOID VALVE)



• Fuel tank shroud →3-13

EVAP Purge Control Solenoid Valve Diagram

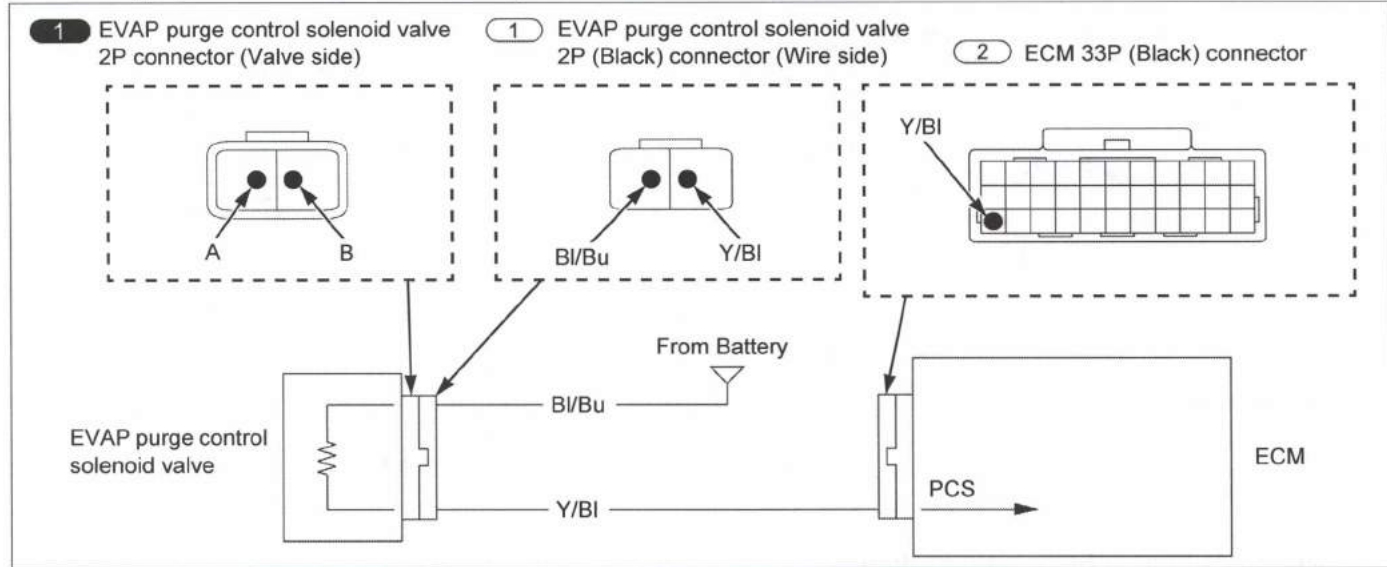

1. EVAP Purge Control Solenoid Valve System Inspection

- Check the EVAP purge control solenoid valve with MCS.
- Is the DTC 88-1 indicated?

Yes ▼

No ►

- Intermittent failure
- Loose or poor contact at the connector

2. EVAP Purge Control Solenoid Valve Input Voltage Inspection



- Connection: BI/Bu (+) – Ground (-)
- Does the battery voltage exist?

Yes ▼

No ►

- Faulty BI/Bu wire

3. EVAP Purge Control Solenoid Valve Signal Line Inspection

- Check for an open or short circuit in Y/BI wire.
- Is there open or short circuit?

No ▼

Yes ►

- Faulty Y/BI wire

4. EVAP Purge Control Solenoid Valve Resistance inspection



- Connection: A – B
- Is the resistance within 30 – 34 Ω (20°C)?

Yes ▼

No ►

- Faulty EVAP purge control solenoid valve

- Replace the ECM with a new one →4-25, and re-check.



P0412 (PAIR CONTROL SOLENOID VALVE)



• Fuel tank shroud →3-13

PAIR Control Solenoid Valve Diagram

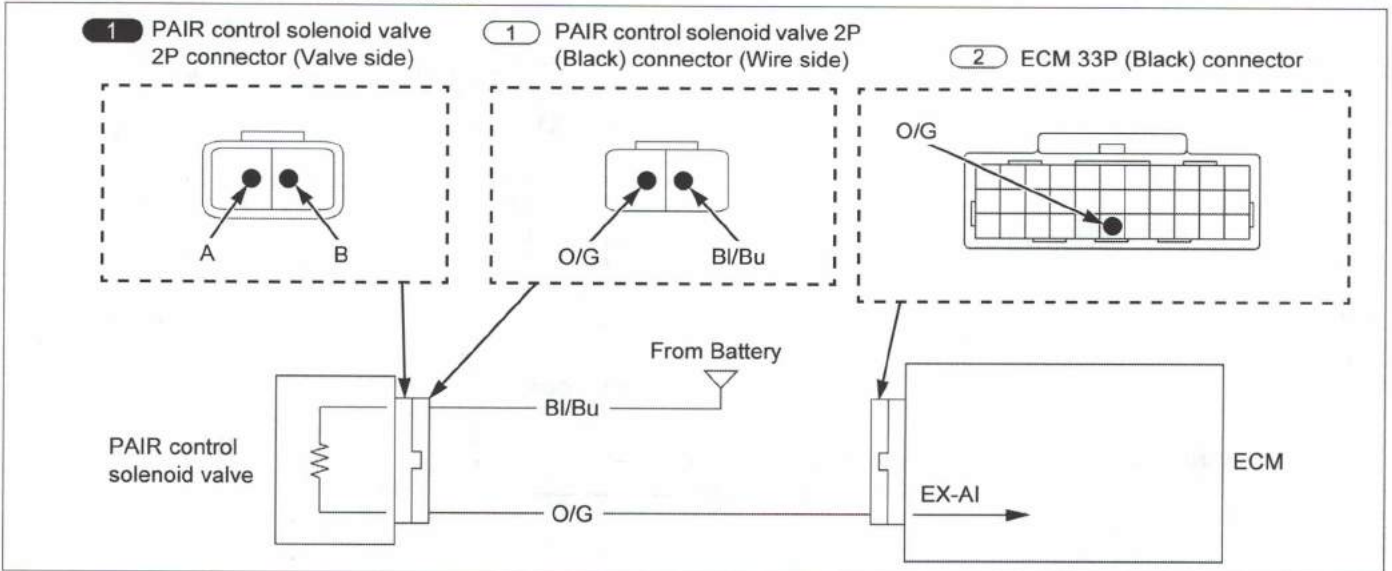

1. PAIR Control Solenoid Valve System Inspection

- Check the PAIR Control Solenoid Valve with MCS.
- Is the DTC 89-1 indicated?

No
▶

- Intermittent failure
- Loose or poor contact at the connector

Yes ▼

2. PAIR Control Solenoid Valve Input Voltage Inspection

- Connection: BI/Bu (+) – Ground (-)
- Does the battery voltage exist?

No
▶

- Faulty BI/Bu wire

Yes ▼

3. PAIR Control Solenoid Valve Signal Line Inspection

- Check for an open or short circuit in O/G wire.
- Is there open or short circuit?

Yes
▶

- Faulty O/G wire

No ▼

4. PAIR Control Solenoid Valve Resistance Inspection

- Connection: A – B
- Is the resistance within 24 – 28 Ω (20°C)?

No
▶

- Faulty PAIR Control Solenoid Valve

Yes ▼

- Replace the ECM with a new one →4-25, and re-check.



ELECTRICAL SYSTEM

P0351 (IGNITION COIL PRIMARY CIRCUIT)



• Fuel tank shroud →3-13

Ignition Coil Primary Circuit Diagram

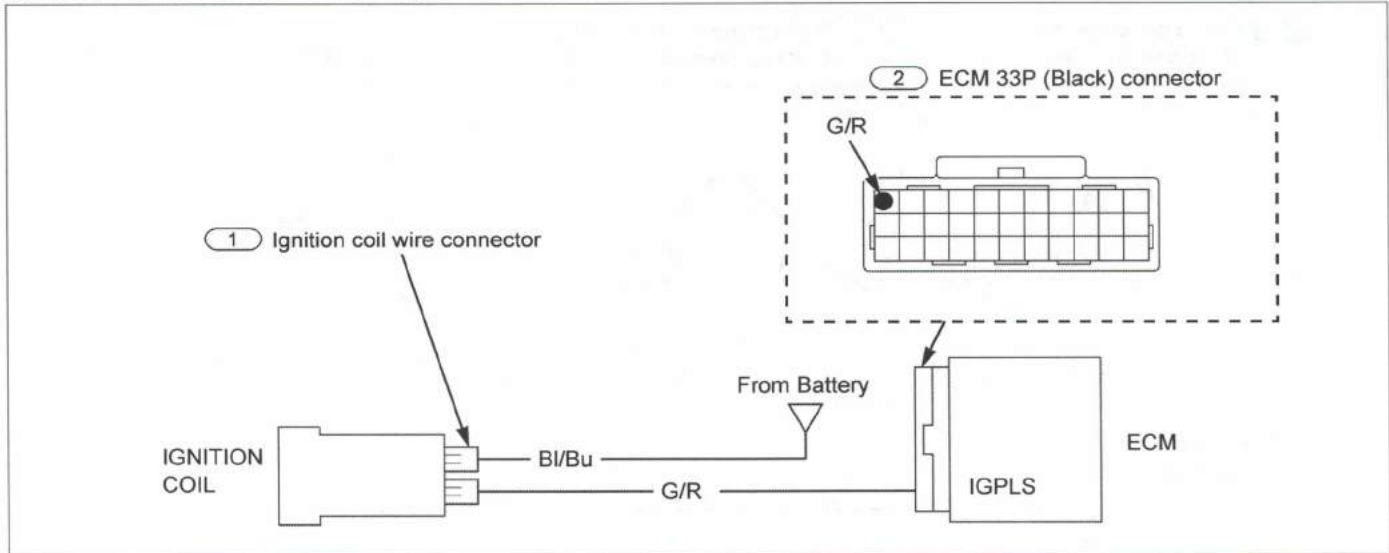

1. Ignition Coil Primary Circuit System Inspection

- Check the Ignition coil with MCS.
- Is the DTC 91-1 indicated?

Yes ▼

No ►

- Intermittent failure
- Loose or poor contact at the connector

2. Ignition Coil Primary Circuit Input Voltage Inspection



- Connection: BI/Bu (+) – Ground (-)
- Does the battery voltage exist?

Yes ▼

No ►

- Faulty BI/Bu wire

3. Ignition Coil Primary Circuit Signal Line Inspection

- Check for an open or short circuit in G/R wire
- Is there open or short circuit?

No ▼

Yes ►

- Faulty G/R wire

4. Ignition Coil Inspection

- Replace the ignition coil with a new one
- Erase the DTC's.
- Test-ride the vehicle and check the ignition coil with MCS.
- If DTC 91-1 is indicated, replace the ECM with a new one →4-25, and recheck.

ECM

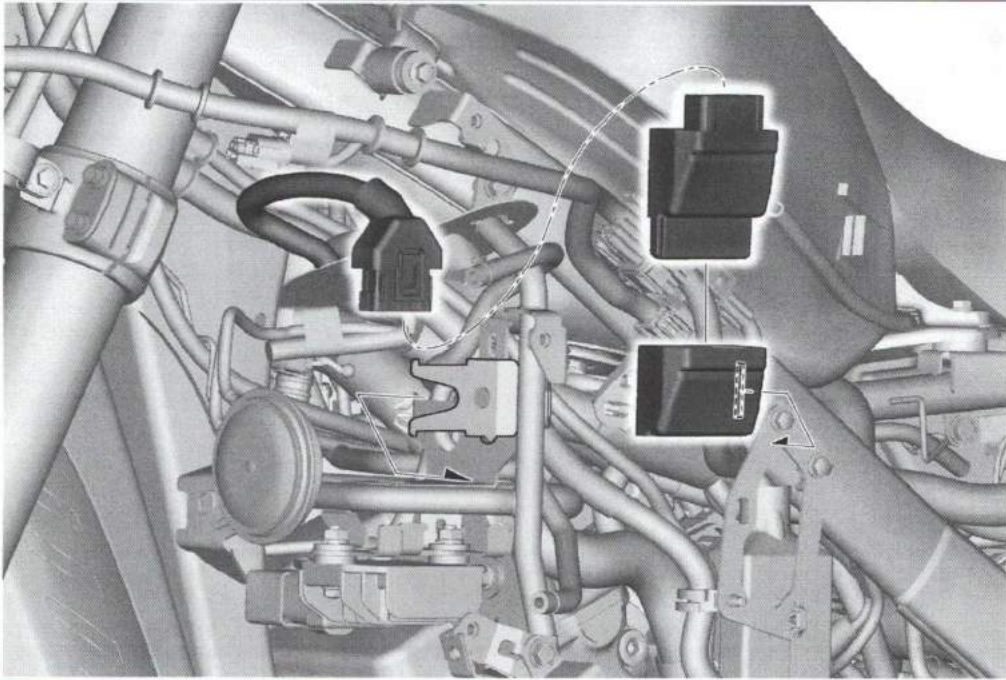

• Left fuel tank shroud →3-13



• ECM power circuit and ground circuit inspection

ECT SENSOR

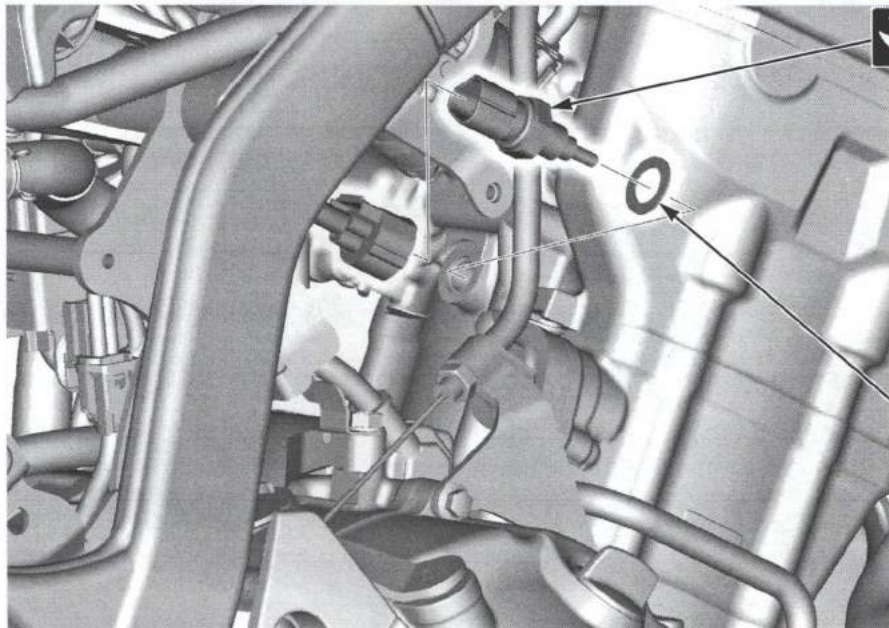

• Right fuel tank shroud →3-13



• ECT sensor inspection



O₂ SENSOR

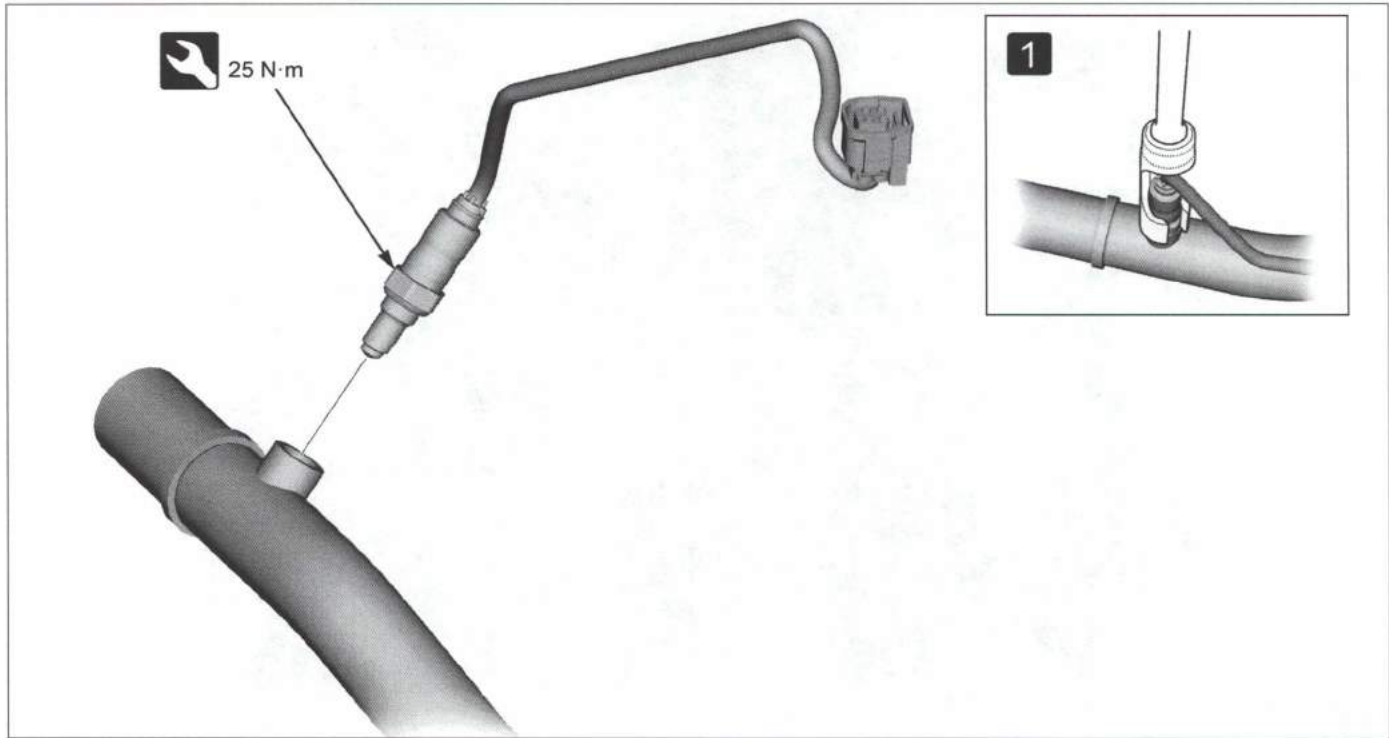

- Exhaust pipe → 3-24
- 1 Remove the O₂ sensor.
Flare nut socket: FRXM17 (Snap on) or equivalent

BANK ANGLE SENSOR

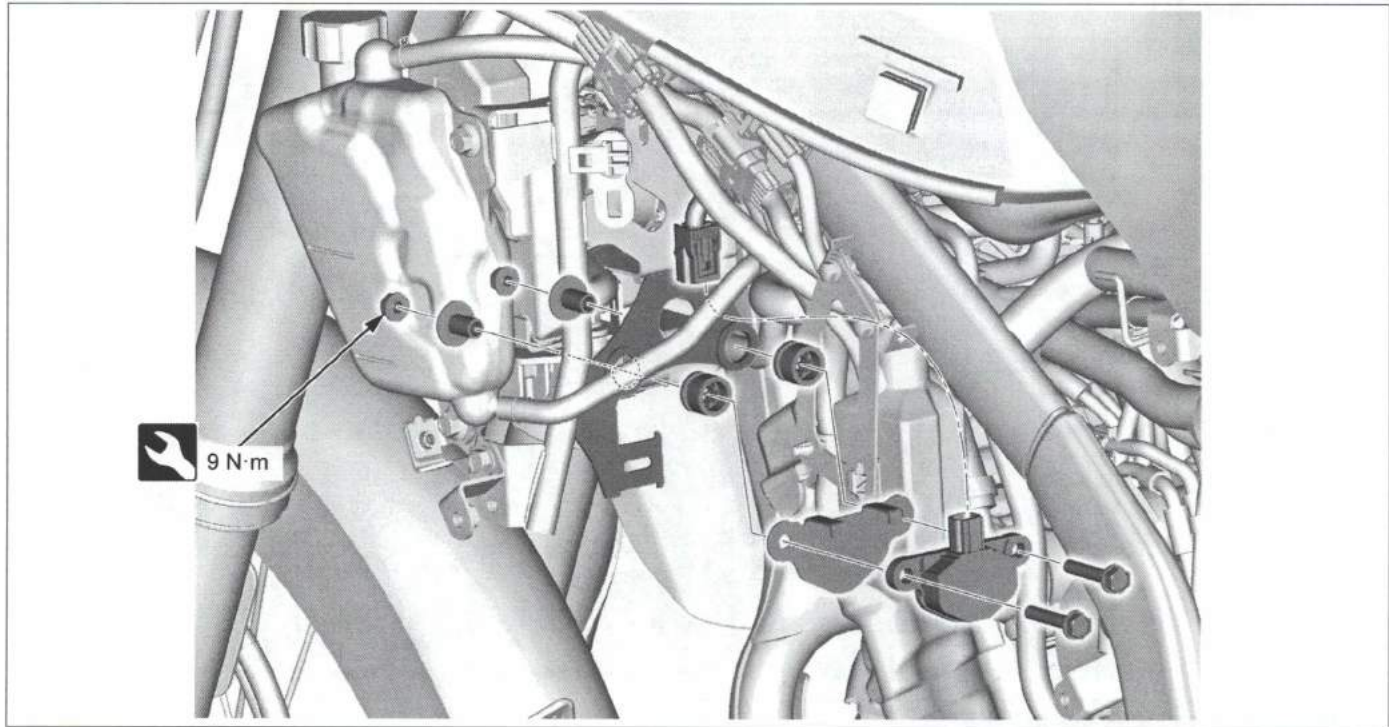

- Left fuel tank shroud → 3-13
- Bank angle sensor inspection





IGNITION SYSTEM

IGNITION SYSTEM LOCATION

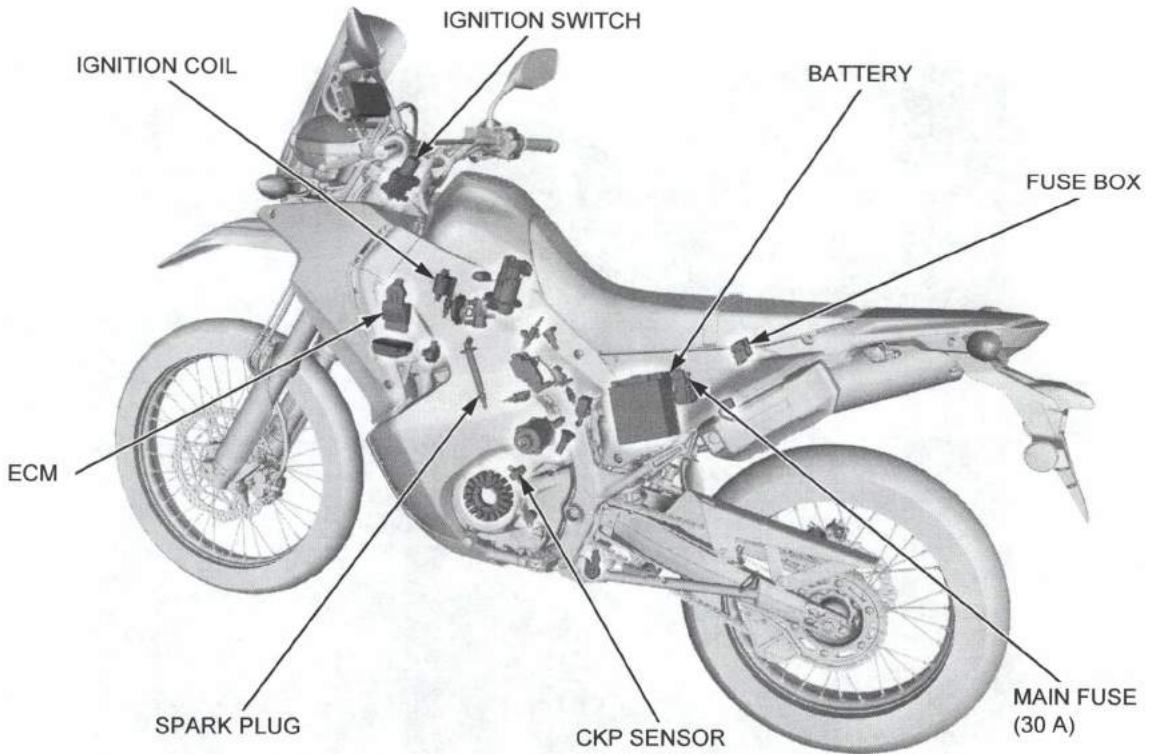

IGNITION SYSTEM DIAGRAM

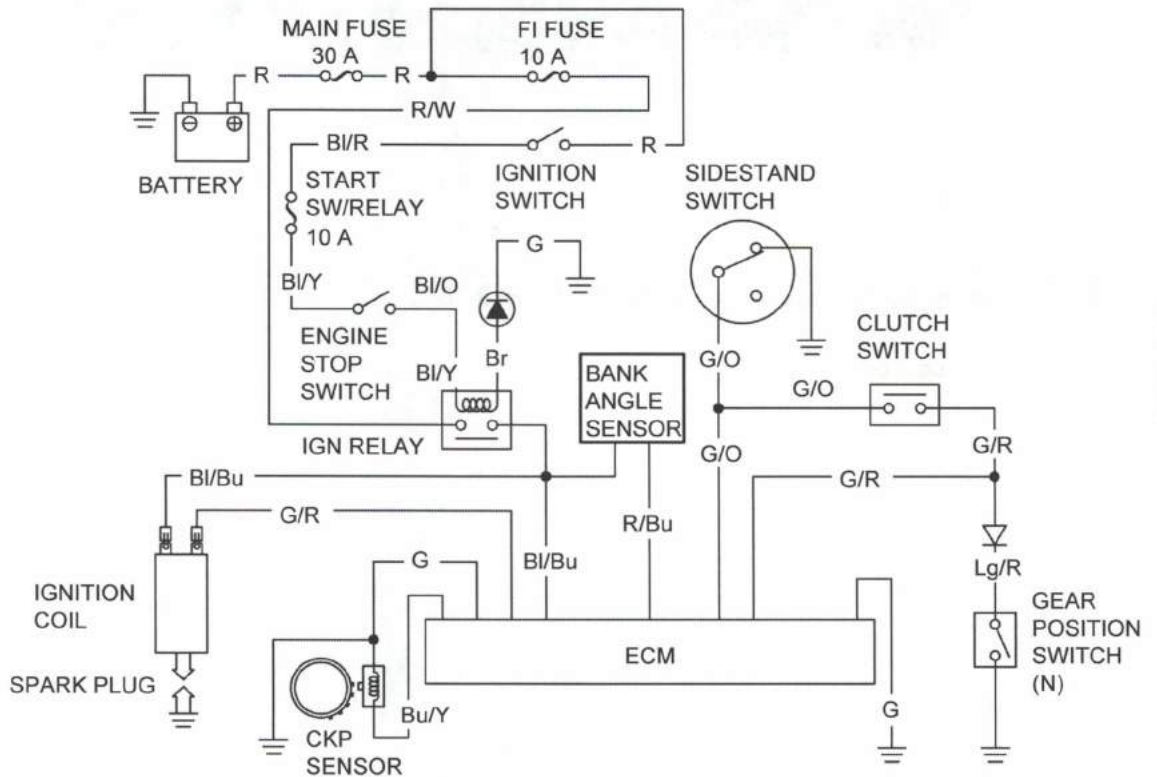



SPARK PLUG REPLACEMENT

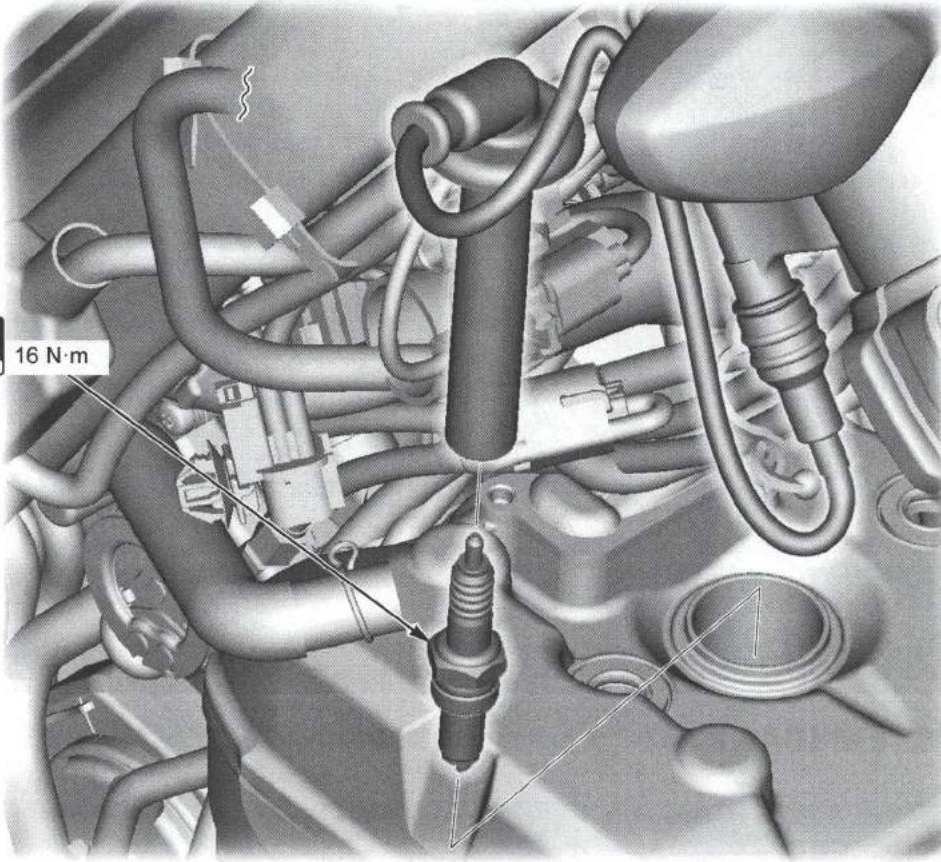

 16 N·m



• Radiator with its hoses connected and cooling fan →2-18



• Spark plug inspection



INSPECTION

IGNITION COIL PRIMARY PEAK VOLTAGE

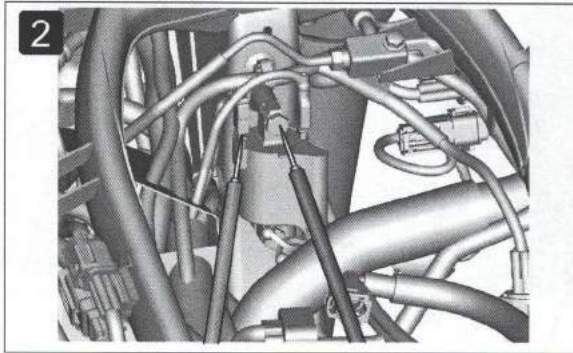
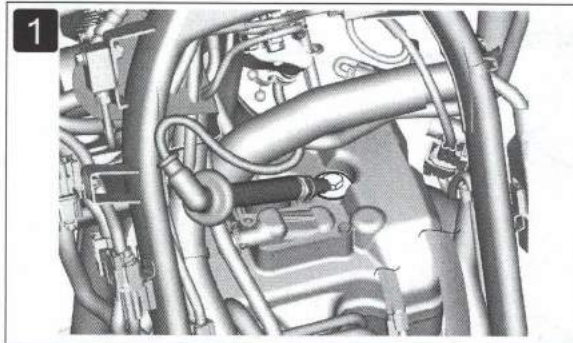

- Refer to "Basic Shop Manual" for the detail information of ignition coil primary peak voltage inspection.

- Fuel tank →2-6

- **1** Connect a known-good spark plug to the spark plug cap and ground it to the cylinder head bolt as done in a spark test.

- **2** With the ignition coil primary wires connected, connect the peak voltage adaptor probes to the ignition coil primary terminal and ground.

CONNECTION: G/R (+) – Ground (-)



- Check the initial voltage at this time.

STANDARD VOLTAGE: Battery voltage

- Shift the transmission into neutral.

- Crank the engine with the starter and measure the ignition coil primary peak voltage.

PEAK VOLTAGE: 100 V minimum

IGNITION TIMING

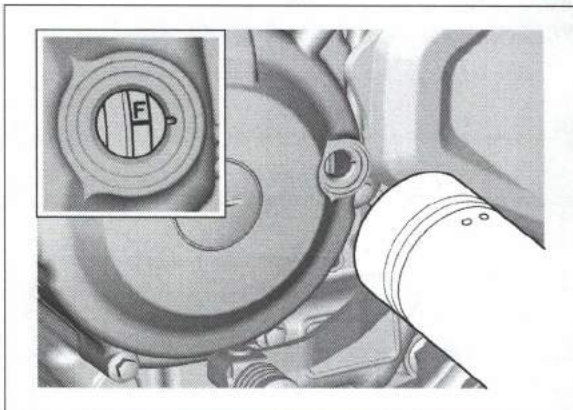

- Warm up the engine normal operating temperature.

- Timing hole cap →2-22

- Connect the timing light to the spark plug wire.

- Start the engine and let it idle

IDLE SPEED: 1,450 ± 100 rpm

- The ignition timing is correct if the "F" mark on the flywheel aligns with the index notch on the left crankcase cover.



ELECTRICAL STARTER

ELECTRICAL STARTER SYSTEM LOCATION

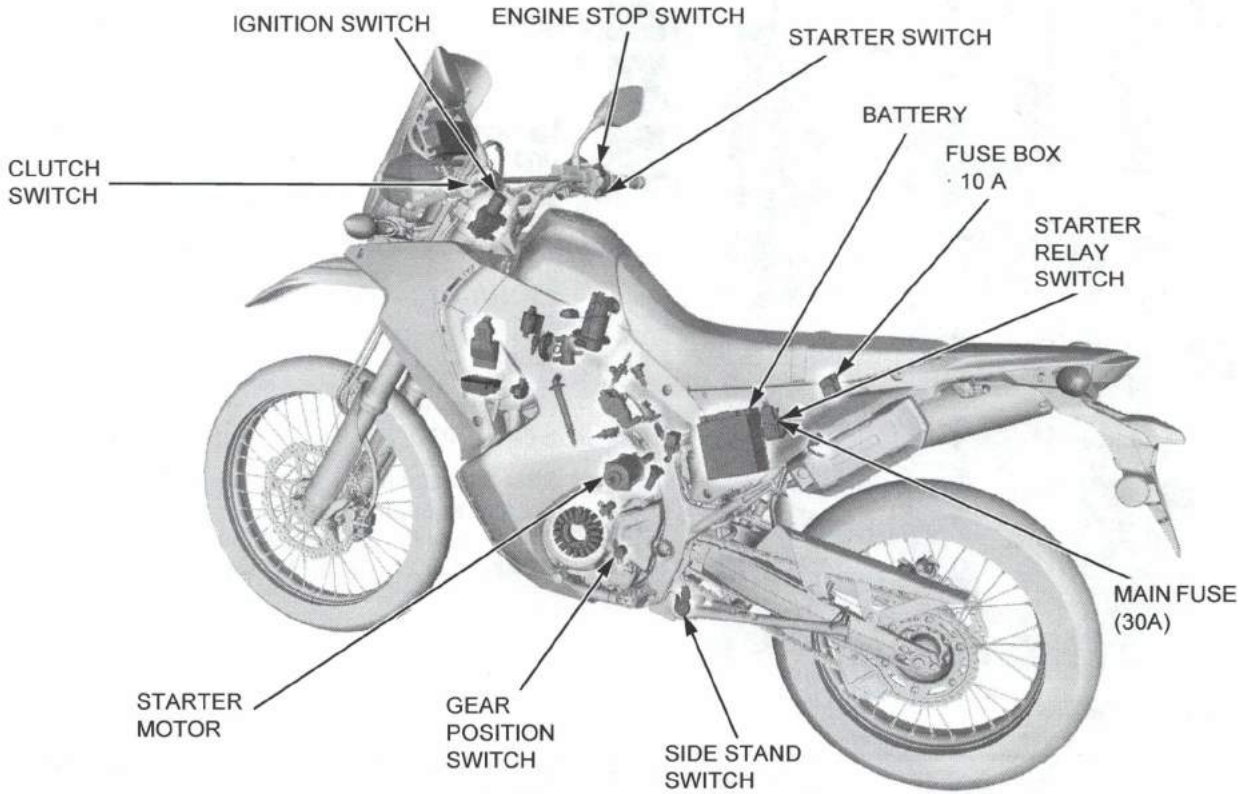

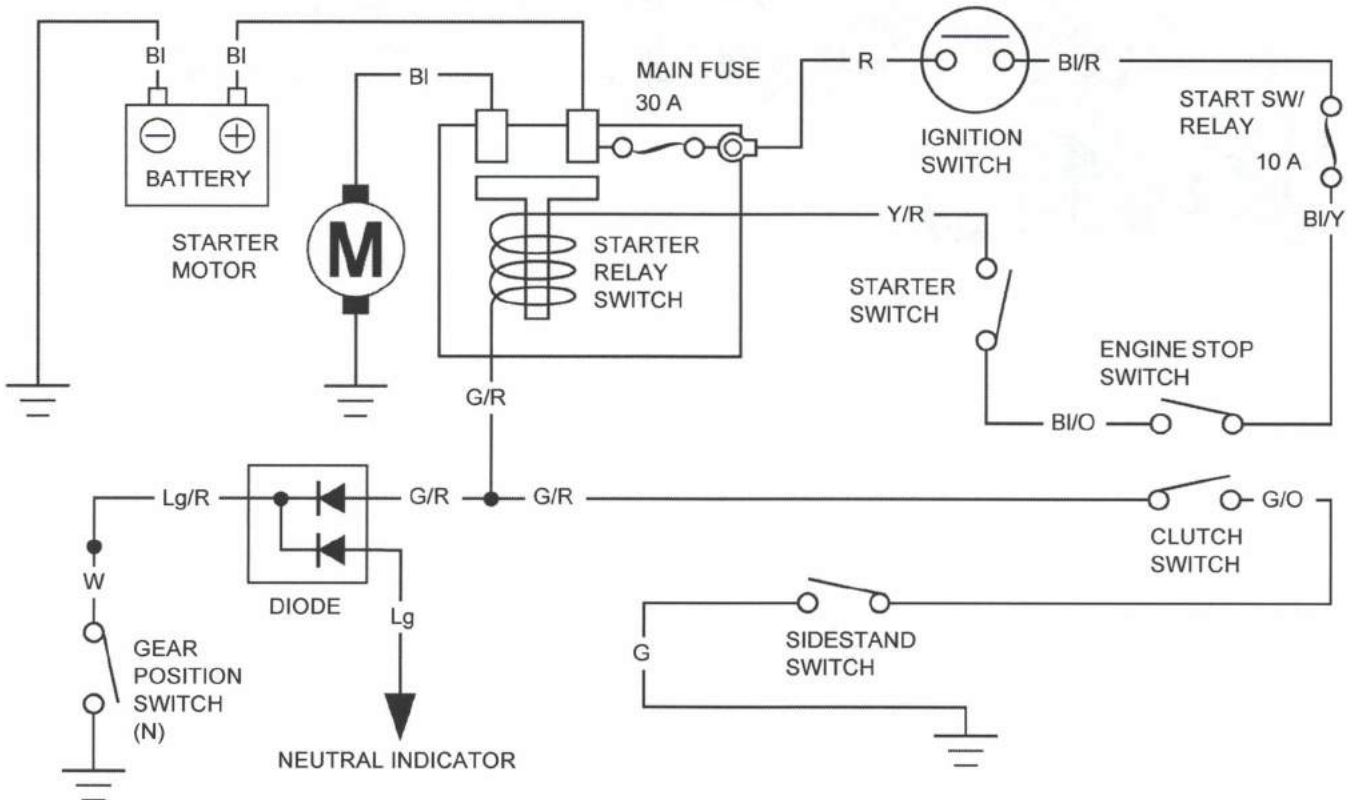

ELECTRICAL STARTER SYSTEM DIAGRAM





ELECTRICAL STARTER TROUBLESHOOTING

STARTER MOTOR DOES NOT TURN

-  • Left side cover →3-8
-  • Loose or poor contacts of related terminal/connector
- Battery condition
- Burned fuse

Connector Diagram



1. Starter Relay Coil Input Circuit Inspection



- Connection: Y/R (+) – Ground (-)
- Push and hold the starter switch.
- Does the battery voltage exist?

Yes ▼

No ►

- Inspect the following.
 - Ignition switch
 - Starter switch
 - Engine stop switch
 - Starter relay coil input circuit related circuit

2. Starter Relay Coil Ground Circuit Inspection



- Connection: G/R – Ground
- Squeeze the clutch lever or transmission in neutral position.
- Squeeze the clutch lever and retract the sidestand or shift the transmission in neutral position.
- Is there continuity?

Yes ▼

No ►

- Inspect the following.
 - Diode
 - Clutch switch
 - Neutral switch
 - Sidestand switch
 - Starter relay coil ground circuit related circuit

3. Starter Relay Inspection

- Replace the starter relay with a new one, and recheck.
- Does the starter motor turn?

No ▼

Yes ►

- Faulty original starter relay

- Check for a short or open circuit in starter motor cable.
- If there is no faulty circuit, replace the Starter motor with a new one, and recheck.



STARTER MOTOR

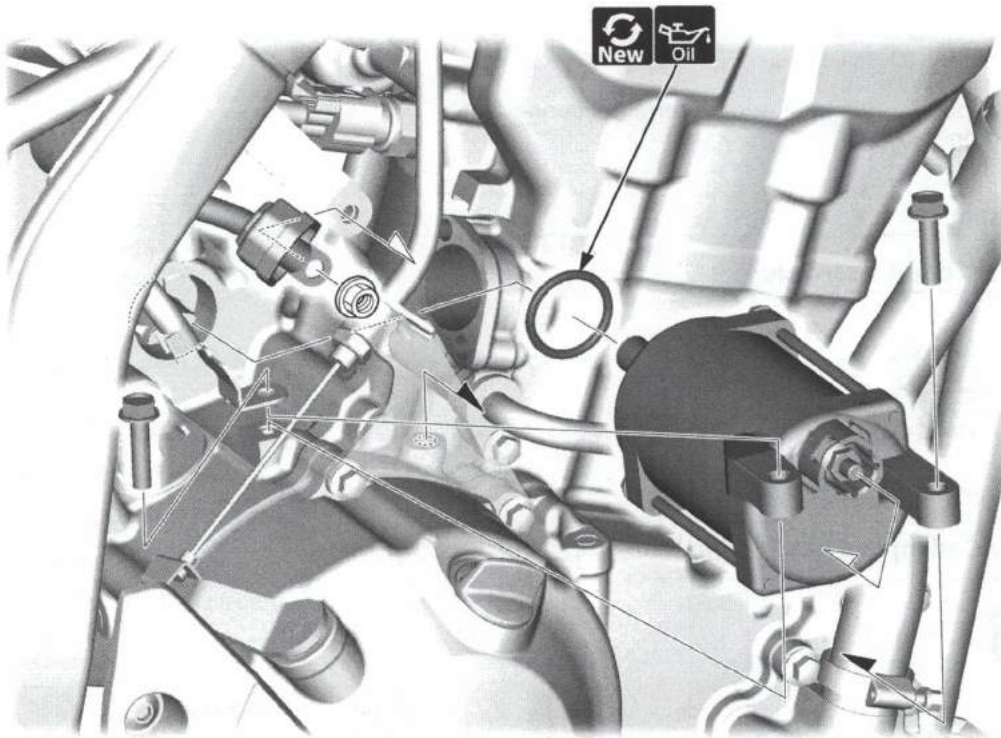

- Exhaust pipe →3-24
- EVAP system (AC type) →2-13
- Cam chain tensioner →2-28



4.9 N·m



3.7 N·m

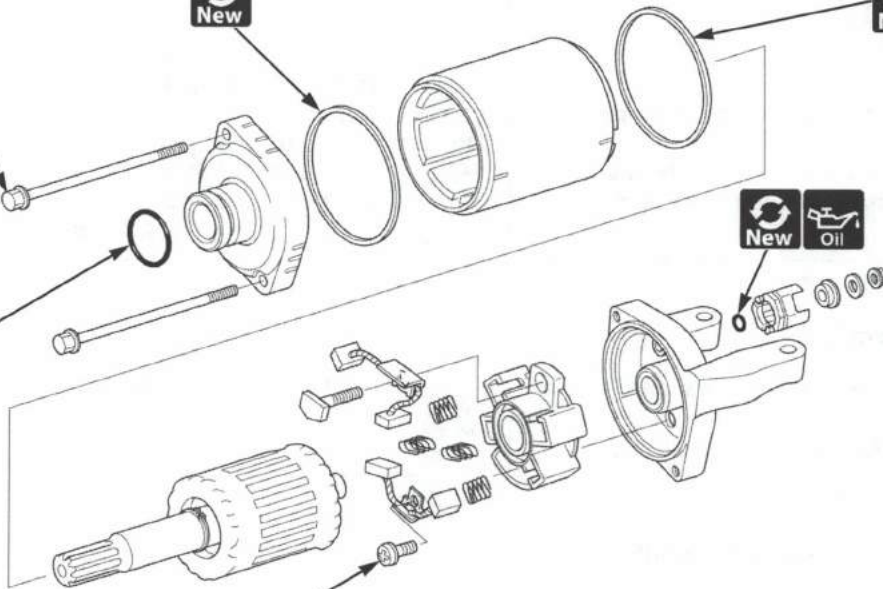

GEAR POSITION SWITCH

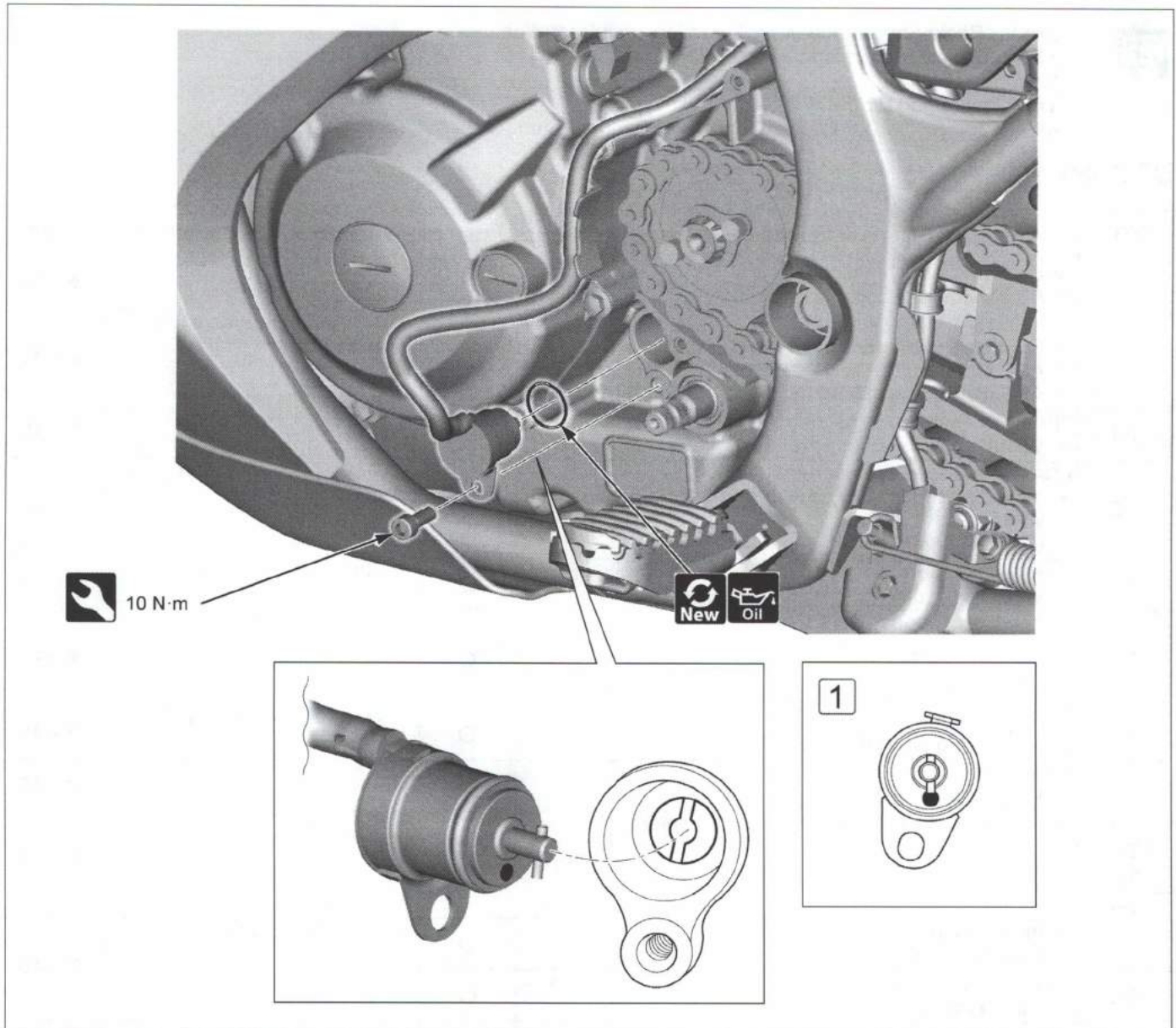

- Engine oil →2-15
- Drive sprocket cover →3-16
- Gear shift pedal →3-16



- ① Set the transmission to neutral and align the switch longer pin with the paint mark.



ELECTRICAL SYSTEM

ABS



- Refer to "Basic Shop manual" for the following information.
 - ABS technical feature and each function.
 - Troubleshooting for the ABS.
 - MCS (Motorcycle Communication System) information.

DTC INDEX

DTC	Function Failure	Detection		Symptom/Fail-safe function	Page
		*A	*B		
-	ABS indicator malfunction <ul style="list-style-type: none"> • ABS modulator voltage input line • Indicator related wires • Combination meter • ABS modulator • ABS MAIN fuse (10 A) 			• ABS indicator never come ON at all	→4-38
				• ABS indicator stays ON	→4-38
1-1	Front wheel speed sensor circuit inspection <ul style="list-style-type: none"> • Wheel speed sensor or related wires 	○	○	• Stops ABS operation	→4-40
1-2	Front wheel speed sensor malfunction <ul style="list-style-type: none"> • Wheel speed sensor, pulser ring or related wires • Electromagnetic interference 		○	• Stops ABS operation	→4-40
1-3	Rear wheel speed sensor circuit malfunction <ul style="list-style-type: none"> • Wheel speed sensor or related wires 	○	○	• Stops ABS operation	→4-41
1-4	Rear wheel speed sensor malfunction <ul style="list-style-type: none"> • Wheel speed sensor, pulser ring or related wires • Electromagnetic interference 		○	• Stops ABS operation	→4-41
2-1	Front pulser ring <ul style="list-style-type: none"> • Pulser ring or related wires 		○	• Stops ABS operation	→4-40
2-3	Rear pulser ring <ul style="list-style-type: none"> • Pulser ring or related wires 		○	• Stops ABS operation	→4-41
3-1	Solenoid valve malfunction (ABS modulator)			• Stops ABS operation	→4-42
3-2					
3-3		○	○		
3-4					
4-1	Front wheel lock <ul style="list-style-type: none"> • Riding condition 		○	• Stops ABS operation	→4-40
4-2	Front wheel lock (Wheelie) <ul style="list-style-type: none"> • Riding condition 		○		
4-3	Rear wheel lock <ul style="list-style-type: none"> • Riding condition 		○	• Stops ABS operation	→4-41
5-1	Pump motor lock <ul style="list-style-type: none"> • Pump motor (ABS modulator) or related wires • MR+B fuse (30 A) 	○	○	• Stops ABS operation	→4-43
5-2	Pump motor stuck off <ul style="list-style-type: none"> • Pump motor (ABS modulator) or related wires • MR+B fuse (30 A) 	○	○	• Stops ABS operation	→4-43
5-3	Pump motor stuck on <ul style="list-style-type: none"> • Pump motor (ABS modulator) or related wires • MR+B fuse (30 A) 	○	○	• Stops ABS operation	→4-43
5-4	Power supply relay malfunction <ul style="list-style-type: none"> • Power supply relay (ABS modulator) or related wires • FSR+B fuse (30 A) 	○	○	• Stops ABS operation	→4-44



DTC	Function Failure	Detection		Symptom/Fail-safe function	Page
		*A	*B		
6-1	Power circuit under voltage <ul style="list-style-type: none"> • Input footage (too low) • ABS MAIN fuse (10 A) 	○	○	• Stops ABS operation	→4-45
6-2	Power circuit over voltage <ul style="list-style-type: none"> • Input voltage (too high) 	○	○	• Stops ABS operation	→4-45
7-1	Tire malfunction <ul style="list-style-type: none"> • Tire size • Incorrect sprocket gear ratio (Sprockets not recommended for the vehicle are installed.) 		○	• Stops ABS operation	→4-46
8-1	ABS control unit <ul style="list-style-type: none"> • ABS control unit malfunction (ABS modulator) 	○	○	• Stops ABS operation	→4-46
8-2	Rear ABS off indicator <ul style="list-style-type: none"> • Rear ABS off indicator or related wire 	○	○	• Rear ABS off mode function does not work	→4-47

*A: Pre-start self-diagnosis

*B: Ordinary self-diagnosis: diagnoses while the vehicle is running (after pre-start self-diagnosis)



ELECTRICAL SYSTEM

How To Erase the DTC Without MCS



- Connect the DLC.
- Squeeze the brake lever.



- The ABS indicator should come on 2 seconds and go off.
- After the ABS indicator is off, release the brake lever immediately.
- After the ABS indicator is on, squeeze the brake lever immediately.
- After the ABS indicator is off, release the brake lever immediately.
 - When code erasure is complete, the ABS indicator blinks 2 times and stay on.
 - If the ABS indicator does not blink, the data has not been erased, so try again.

ABS LOCATION

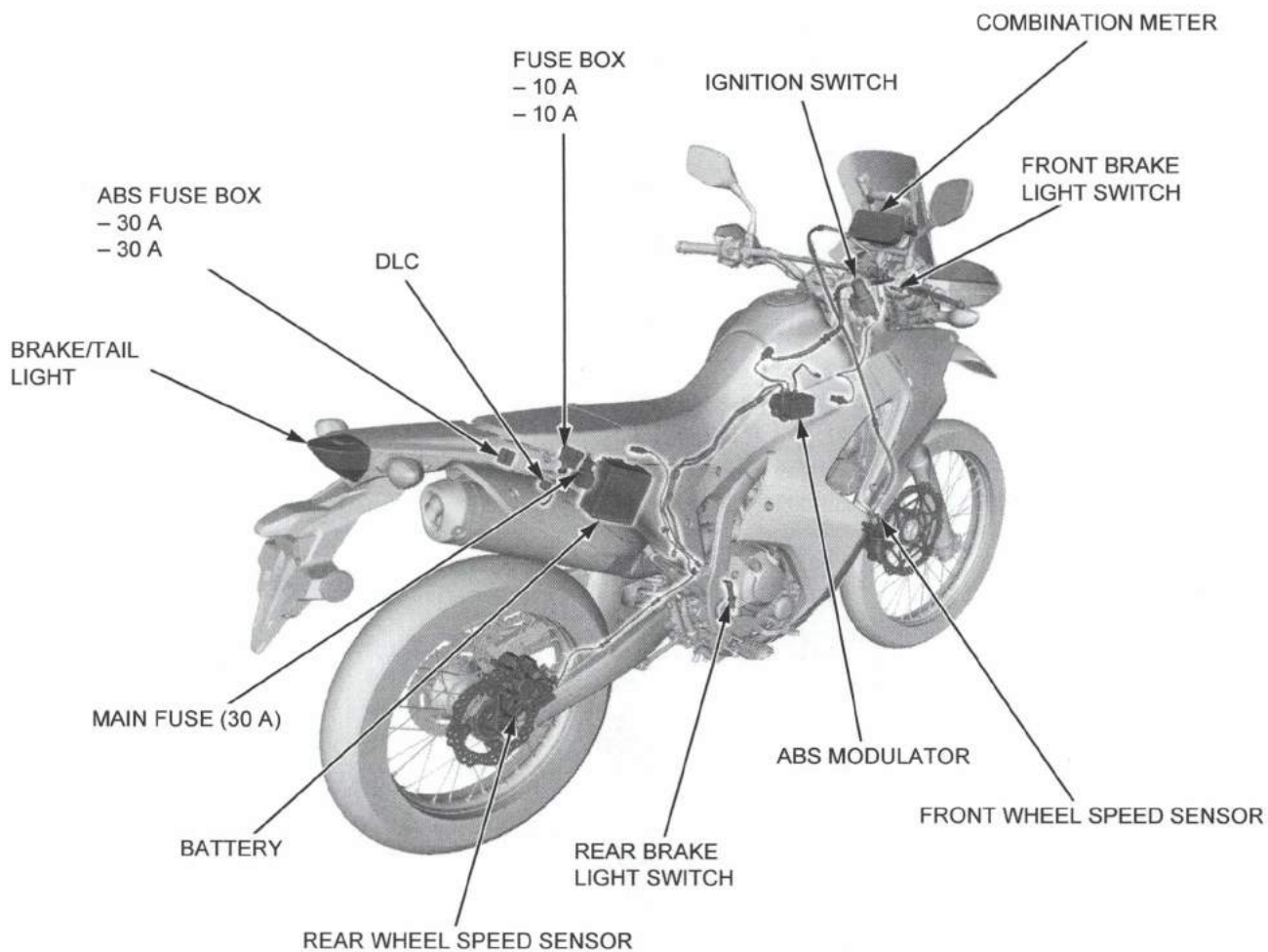



ABS DIAGRAM

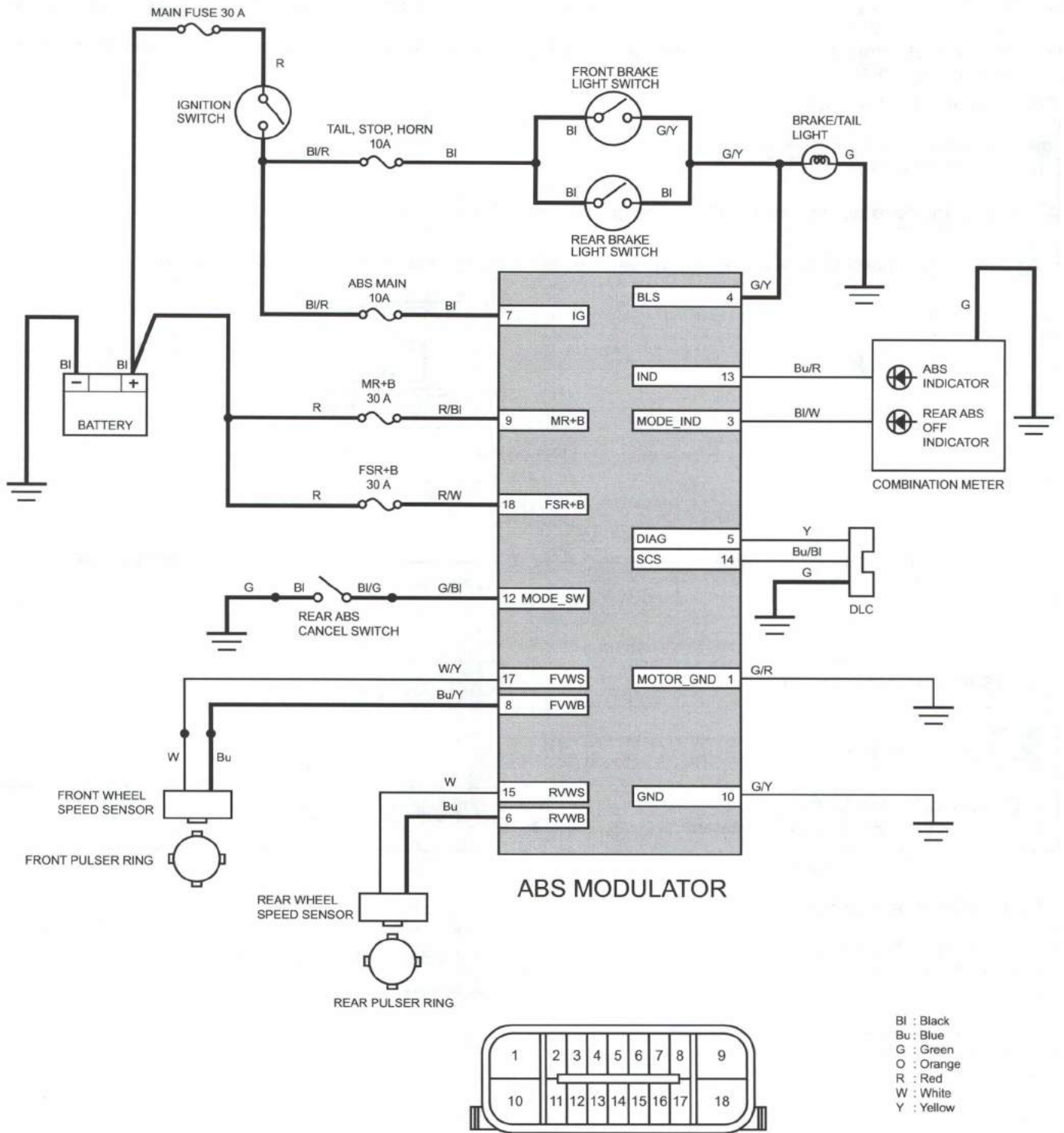

ABS MODULATOR 18P (Black) CONNECTOR (MODULATOR SIDE)



DTC TROUBLESHOOTING

- Before starting this troubleshooting, check the burned fuse and initial function of the combination meter.
- Use a fully charged battery. Do not diagnose with a charger connected to the battery.
- Perform inspection with the ignition switch OFF, unless otherwise specified.
- All connector diagrams in the troubleshooting are viewed from the terminal side.
- When the ABS modulator assembly is detected to be faulty, recheck the wire harness and connector connections closely before replacing it.
- After diagnostic troubleshooting, erase the DTC and test-ride the vehicle to check that the ABS indicator operates normally during pre-start self-diagnosis.

ABS indicator malfunction



- Rally type: Wind screen →3-5
- Standard type: Front visor →3-6

ABS indicator does not come ON (When the ignition switch ON)

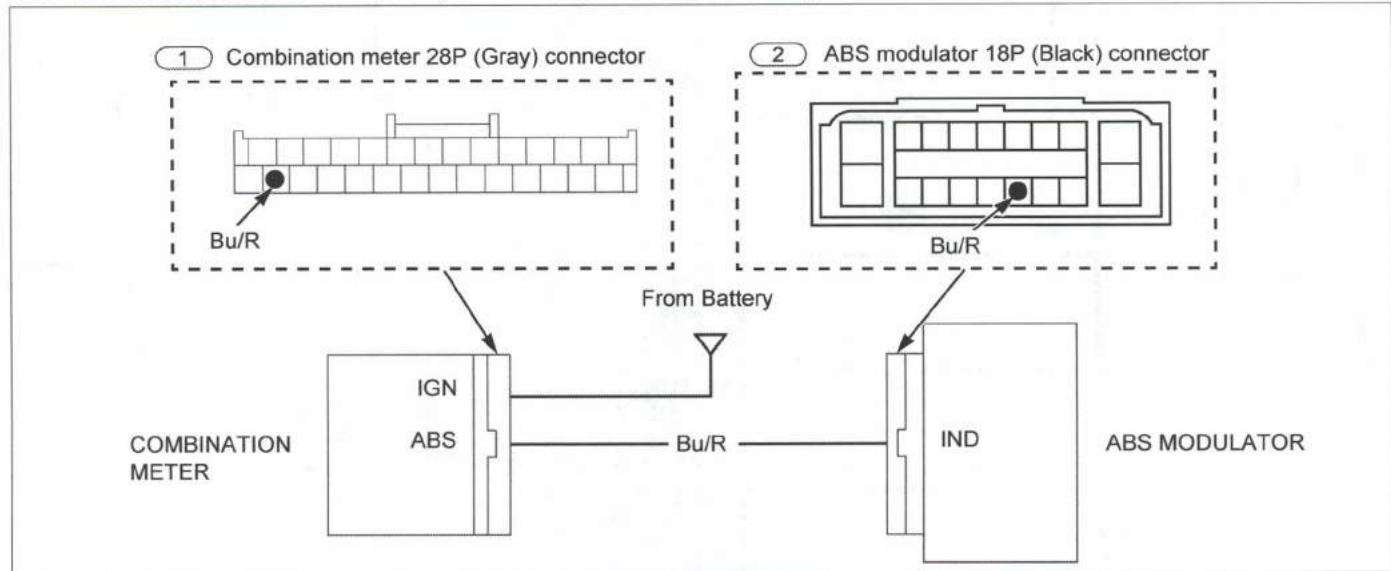

1. ABS Indicator Inspection

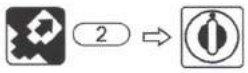

- Check the ABS indicator.
- Does not the ABS indicator come on?

No ▼

Yes ►

- Faulty ABS modulator

2. ABS indicator Line Inspection

- Check for a short circuit in Bu/R wire.
- Is there short circuit?

Yes ▼

No ►

- Faulty combination meter

- Faulty Bu/R wire

ABS indicator stays ON (Indicator does not go off when the motorcycle is running, but DTC is not stored)

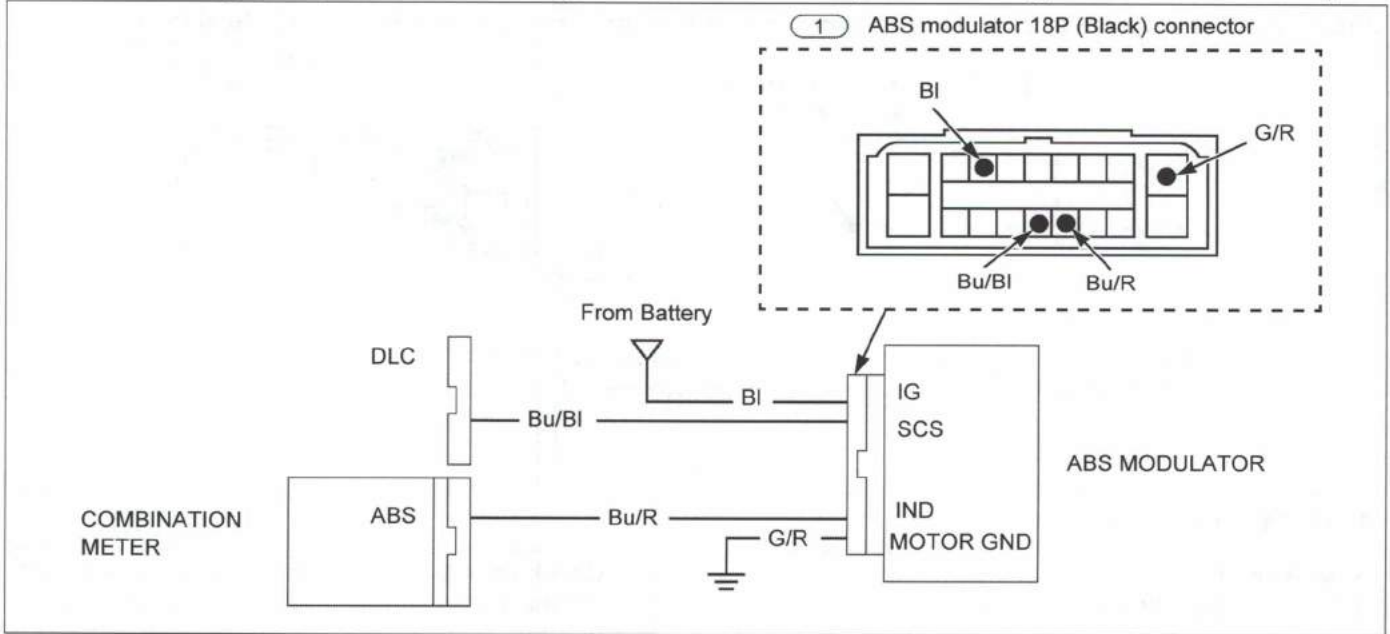

1. Service Check Line Inspection

- Check for a short circuit in Bu/BI wire.
- Is there short circuit?

Yes
▶

- Faulty Bu/BI wire

No ▼

2. ABS Indicator Line Inspection

- Install a jumper wire between the terminal and ground.
- Jumper terminal: Bu/R
- Does the ABS indicator go off?

No
▶

- Faulty Bu/R wire
- If wire is ok, faulty combination meter.

Yes ▼

3. ABS Modulator Ground Line Inspection

- Check for an open circuit in G/R wire.
- Is there open circuit?

Yes
▶

- Faulty G/R wire

No ▼

4. ABS Modulator Power Line Inspection

- Connection: BI (+) – Ground (-)
- Does the battery voltage exist?

No
▶

- Faulty BI wire

Yes ▼

- Faulty ABS modulator



ELECTRICAL SYSTEM

DTC 1-1, 1-2, 2-1, 4-1 or 4-2

(Front wheel speed sensor circuit / Front wheel speed sensor / Front pulser ring / Front wheel lock)

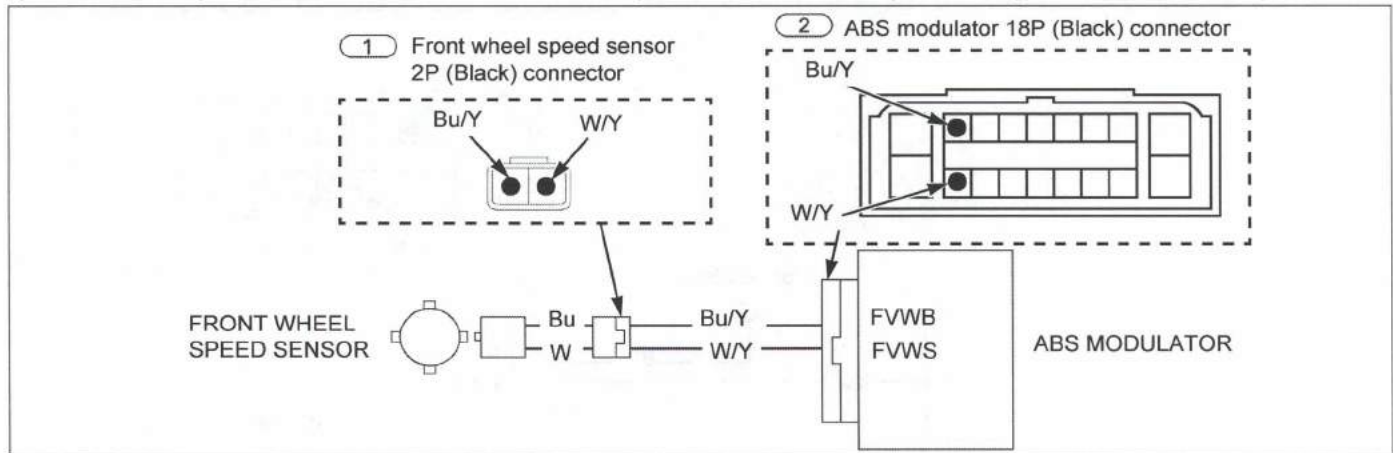

1. Air Gap Inspection

- Measure the air gap.
- Is the air gap correct?

Yes ▼

No ►

- Check each part for deformation, looseness and correct accordingly. Recheck the air gap.

2. Wheel Speed Sensor and Pulser Ring Inspection

- Check the wheel speed sensor and pulser ring.
- Are the sensor and pulser ring in good condition and properly installed?

Yes ▼

No ►

- Remove any deposits.
- Install properly or replace faulty part.

3. Speed Sensor Line Inspection 1



1 2

- Install a jumper wire between the terminals. Jumper terminal: W/Y and Bu/Y
- Check for continuity between the above wires.
- Is there continuity?

Yes ▼

No ►

- Faulty W/Y or Bu/Y wire

4. Speed Sensor Line Inspection 2

- Check for a short circuit in Bu, Bu/Y, W and W/Y wire.
- Is there short circuit?

No ▼

Yes ►

- Faulty Bu, Bu/Y, W or W/Y wire

5. Failure Reproduction

- Replace the speed sensor with a new one. →4-48
- Erase the DTC and test-ride the vehicle above 30 km/h, then recheck the DTC.
- Is the DTC 1-1, 1-2, 2-1, 4-1 or 4-2 indicated?

Yes ▼

No ►

- Faulty original speed sensor

- Faulty ABS modulator



DTC 1-3, 1-4, 2-3 or 4-3

(Rear wheel speed sensor circuit / Rear wheel speed sensor / Rear pulser ring/ Rear wheel lock)

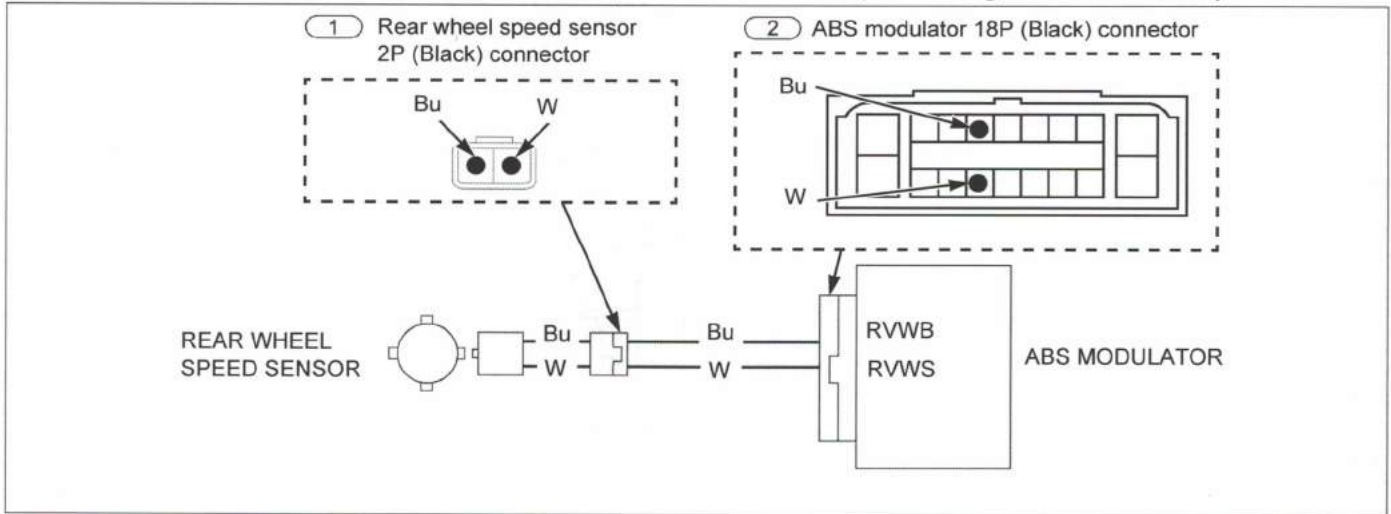

1. Air Gap Inspection

- Measure the air gap.
- Is the air gap correct?

Yes ▼

- No ▶
- Check each part for deformation, looseness and correct accordingly. Recheck the air gap.

2. Speed Sensor and Pulser Ring Inspection

- Check the speed sensor and pulser ring.
- Are the sensor and pulser ring in good condition and properly installed?

Yes ▼

- No ▶
- Remove any deposits.
 - Install properly or replace faulty part.

3. Speed Sensor Line Inspection 1

- 
- 1 2
- Install a jumper wire between the terminals. Jumper terminal: W and Bu
 - Check for continuity between the above wires.
 - Is there continuity?

Yes ▼

- No ▶
- Faulty W or Bu wire

4. Speed Sensor Line Inspection 2

- Check for a short circuit in Bu and W wire.
- Is there short circuit?

No ▼

- Yes ▶
- Faulty Bu or W wire

5. Failure Reproduction

- Replace the speed sensor with a new one. →4-48
- Erase the DTC and test-ride the vehicle above 30 km/h, then recheck the DTC.
- Is the DTC 1-3, 1-4, 2-3 or 4-3 indicated?

Yes ▼

- No ▶
- Faulty original speed sensor

- Faulty ABS modulator



ELECTRICAL SYSTEM

DTC 3-1, 3-2, 3-3 or 3-4

(Solenoid Valve malfunction)

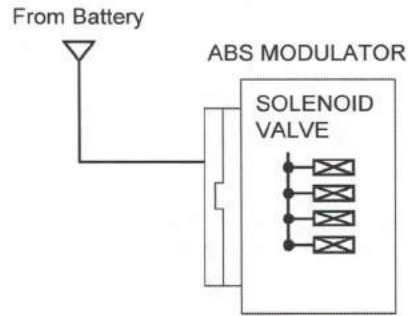

1. Failure Reproduction

- Erase the DTC and test-ride the vehicle above 30 km/h, then recheck the DTC.
- Is the DTC 3-1, 3-2, 3-3 or 3-4 indicated?

No
▶

- Intermittent failure

Yes ▼

- Faulty ABS modulator



DTC 5-1, 5-2 or 5-3

(Pump Motor Lock / Pump motor stuck off / Pump motor stuck on)

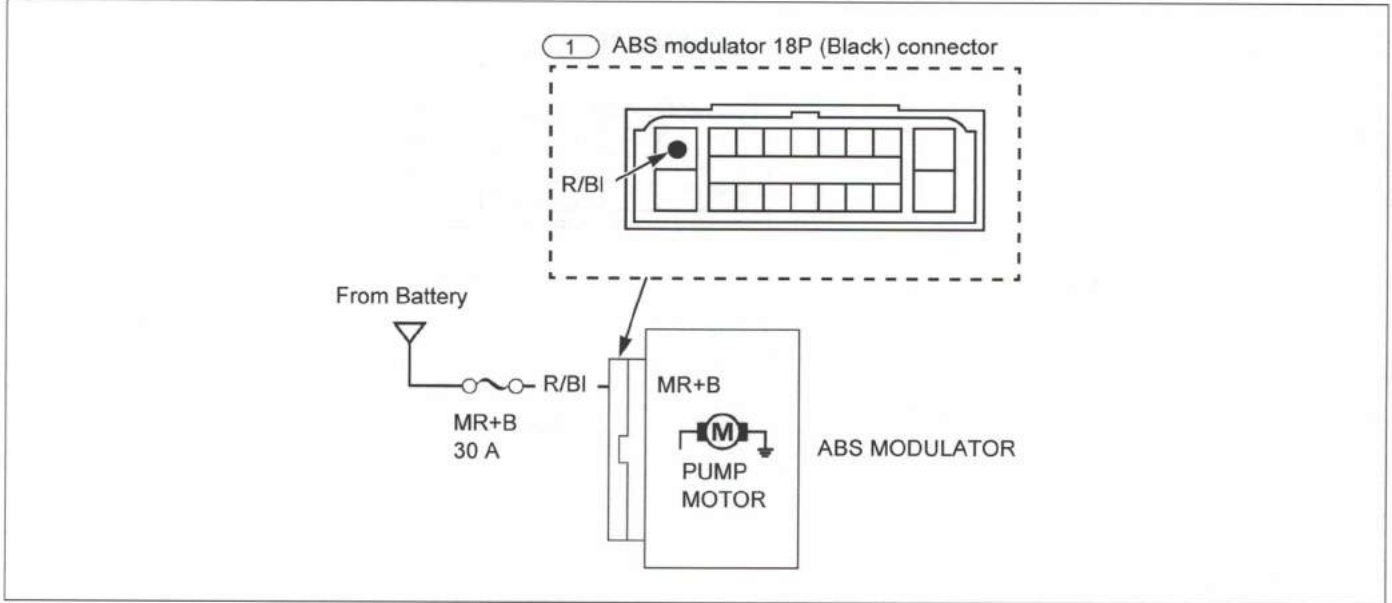

1. ABS Modulator Power Line Inspection 1

- Connection: R/BI (+) – Ground
- Does the battery voltage exist?

Yes ▼

No

▶ • Faulty R/BI wire

2. ABS Modulator Power Line Inspection 2

- Check for a short circuit in R/BI wire.
- Is there short circuit?

No ▼

Yes

▶ • Faulty R/BI wire

3. Failure Reproduction

- Erase the DTC and test-ride the vehicle above 30 km/h, then recheck the DTC.
- Is the DTC 5-1, 5-2 or 5-3 indicated?

Yes ▼

No

▶ • Intermittent failure

• Faulty ABS modulator



DTC 5-4

(Power Supply Relay malfunction)

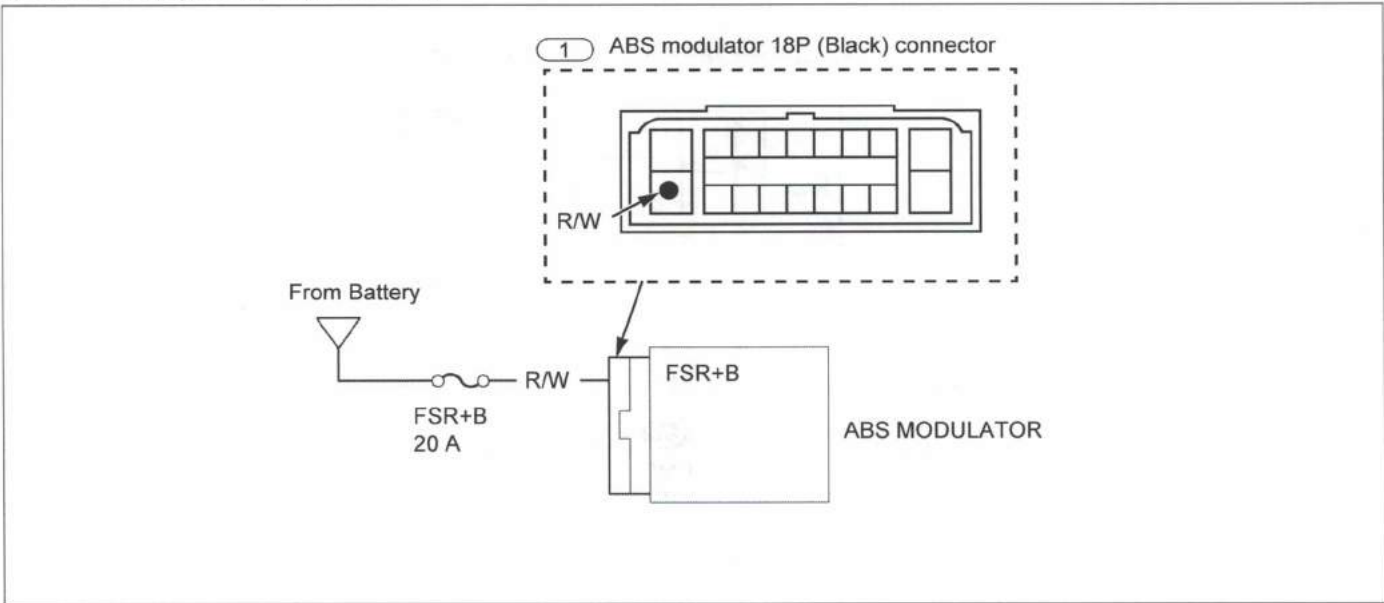

1. ABS Modulator Power Line Inspection 1



- Connection: R/W (+) – Ground
- Does the battery voltage exist?

Yes ▼

No
▶

- Faulty R/W wire

2. ABS Modulator Power Line Inspection 2

- Check for a short circuit in R/W wire.
- Is there short circuit?

No ▼

Yes
▶

- Faulty R/W wire

3. Failure Reproduction

- Erase the DTC and test-ride the vehicle above 30 km/h, then recheck the DTC.
- Is the DTC 5-4 indicated?

Yes ▼

No
▶

- Intermittent failure

- Faulty ABS modulator



DTC 6-1 or 6-2

(Power Circuit)

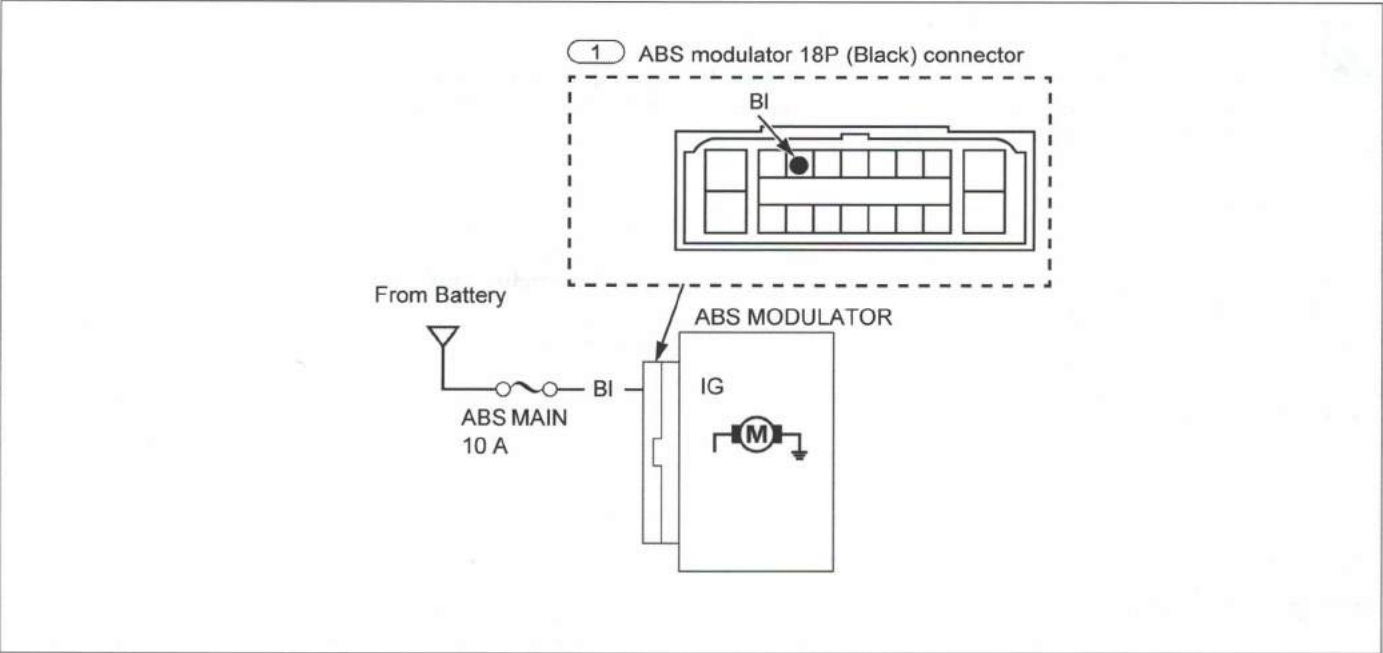

1. ABS Modulator Power Line Inspection 1

- Connection: BI (+) – Ground
- Does the battery voltage exist?

Yes ▼

No ▶

- Faulty BI wire

2. ABS Modulator Power Line Inspection 2

- Check for a short circuit in BI wire.
- Is there short circuit?

No ▼

Yes ▶

- Faulty BI wire

3. Failure Reproduction

- Erase the DTC and test-ride the vehicle above 30 km/h, then recheck the DTC.
- Is the DTC 6-1 or 6-2 indicated?

Yes ▼

No ▶

- Intermittent failure

- Faulty ABS modulator



ELECTRICAL SYSTEM

DTC 7-1

(Tire Size)



- Check the following and correct the faulty part.
- Incorrect tire pressure
- Tires not recommended for the vehicle were installed (incorrect tire size).
- Sprockets not recommended for the vehicle were installed (incorrect sprocket gear ratio).
- Deformation of the wheel or tire.

1. Failure Reproduction

- Erase the DTC and test-ride the vehicle above 30 km/h, then recheck the DTC.
- Is the DTC 7-1 indicated?

Yes ▼

- Faulty ABS modulator

No
▶

- Intermittent failure

DTC 8-1

(ABS Control Unit)

1. Failure Reproduction

- Erase the DTC and test-ride the vehicle above 30 km/h, then recheck the DTC.
- Is the DTC 8-1 indicated?

Yes ▼

- Faulty ABS modulator

No
▶

- Intermittent failure



DTC 8-2

(Rear ABS Off Indicator)

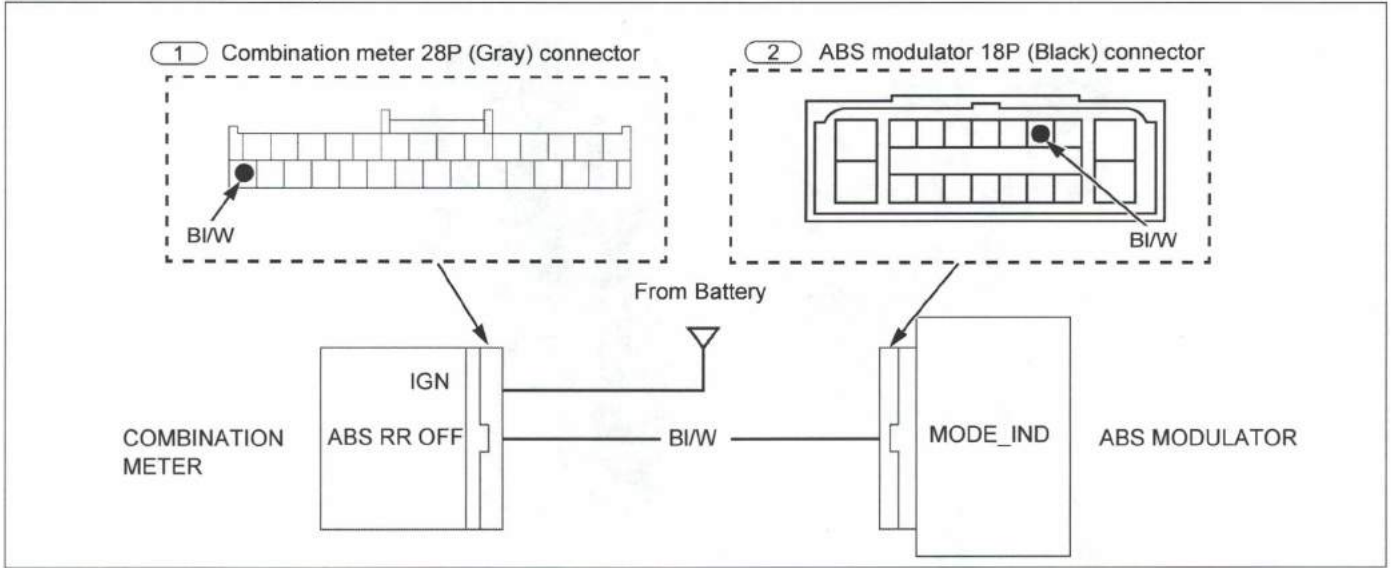

1. ABS Indicator Inspection

2 ⇒

- Check the ABS indicator.
- Does not the ABS indicator come on?

Yes ▶

- Faulty ABS modulator

No ▼

2. ABS indicator Line Inspection

- Check for a short circuit in BI/W wire.
- Is there short circuit?

No ▶

- Faulty combination meter

Yes ▼

- Faulty BI/W wire



WHEEL SPEED SENSOR

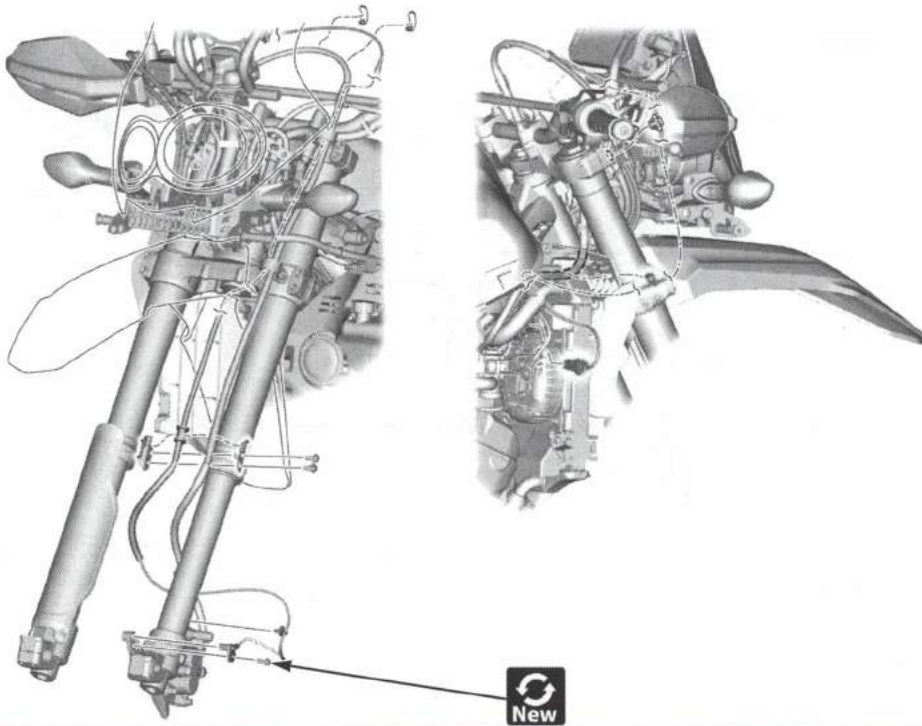

- Front wheel →3-26
- Fuel tank shroud →3-13
- Wheel speed sensor inspection



Basic

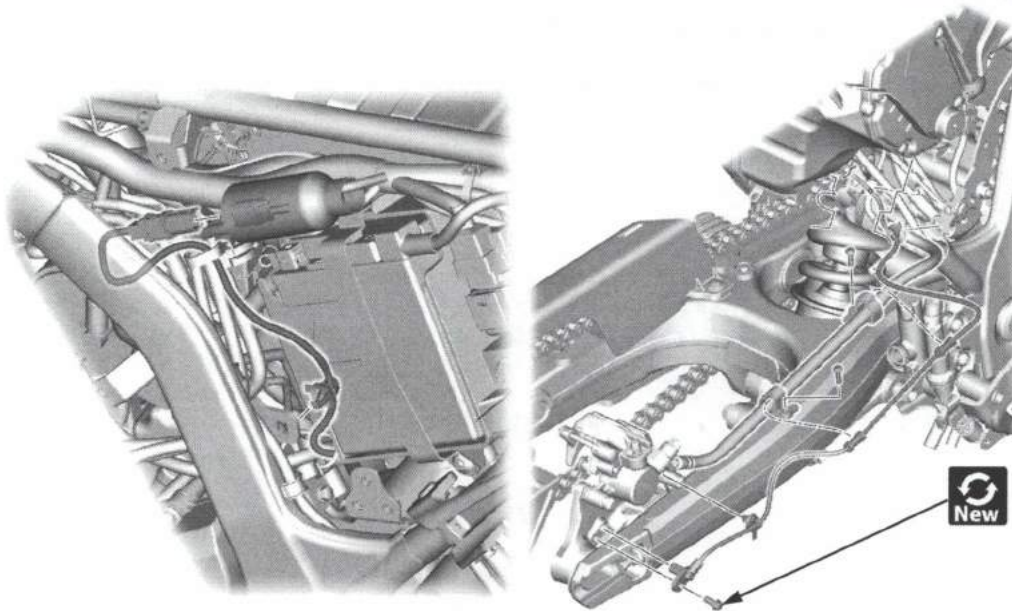

- Rear wheel →3-34
- Left side cover →3-8
- Wheel speed sensor inspection



Basic

ABS MODULATOR

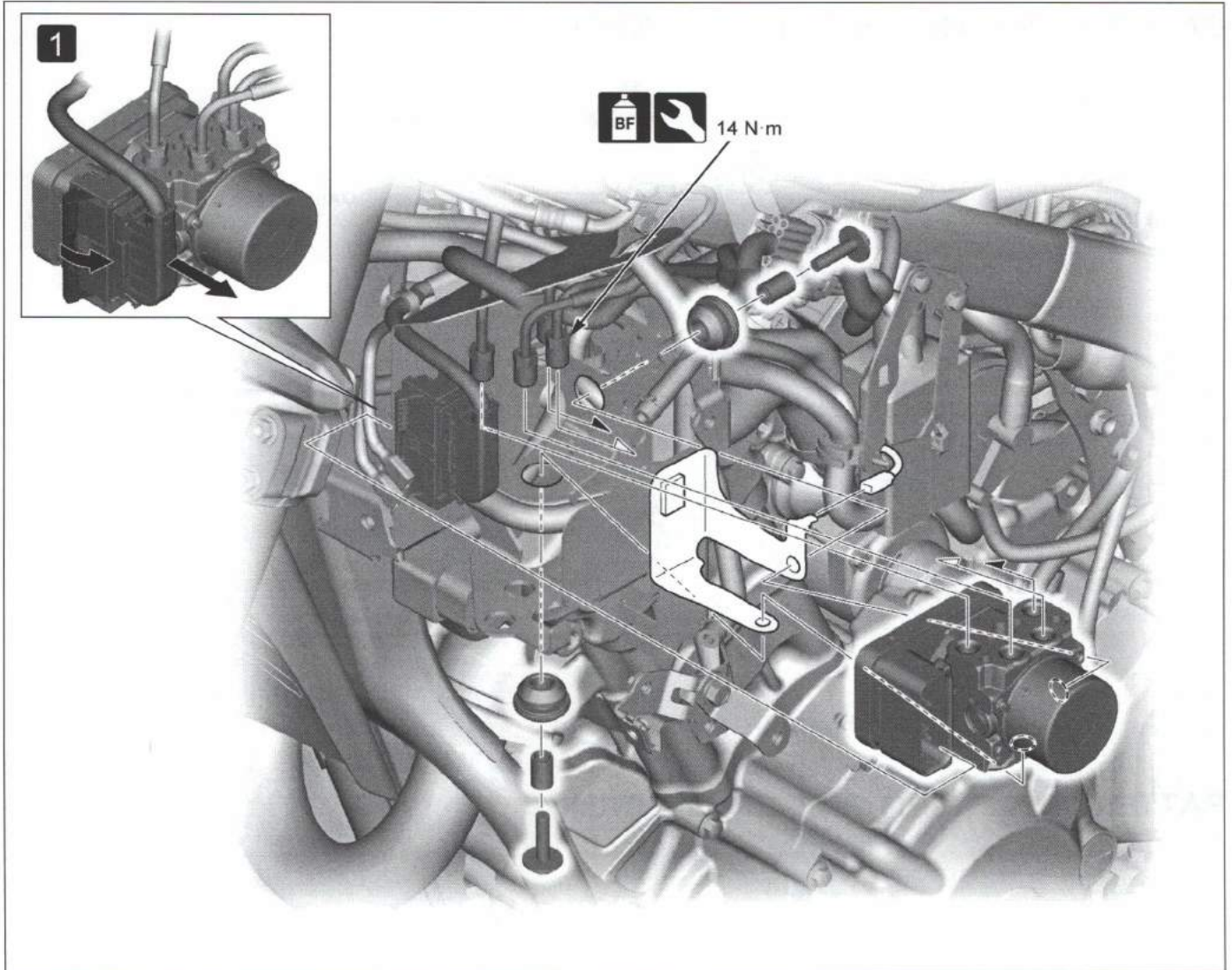

- Regulator/rectifier → 4-51
- Horn → 4-64
- **1** Pull up the lock lever and disconnect the ABS modulator 18P connector.



BATTERY/CHARGING SYSTEM

BATTERY/CHARGING SYSTEM LOCATION

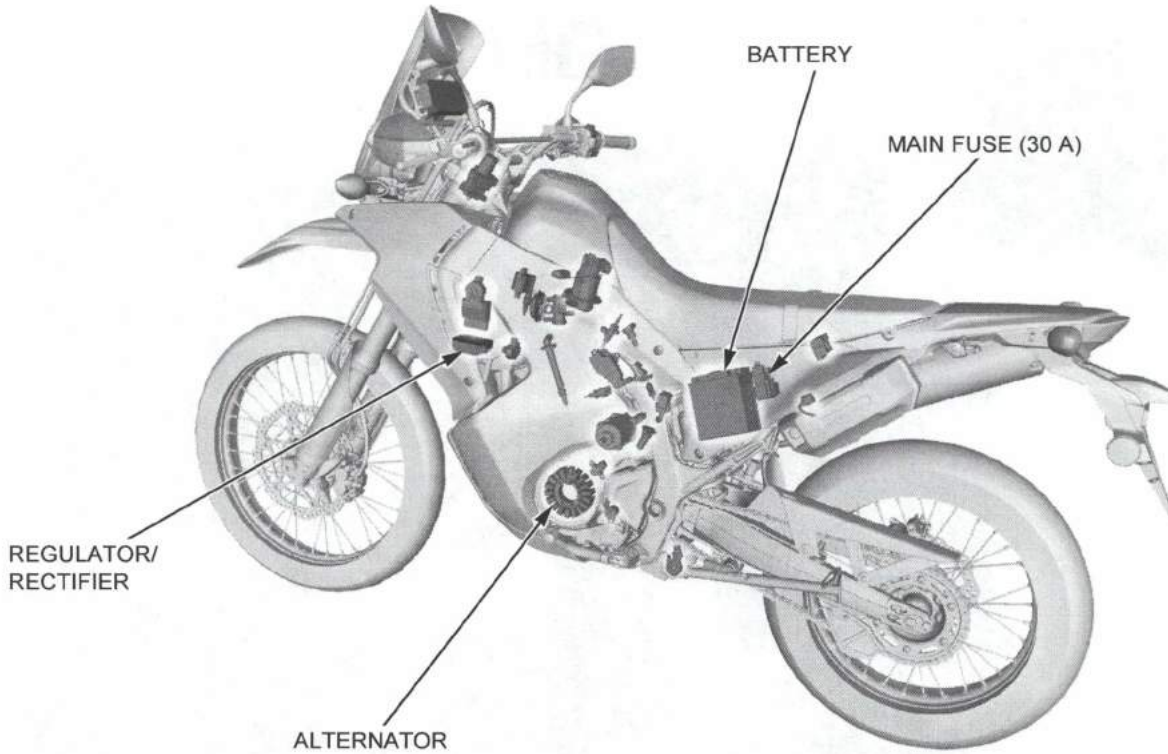

BATTERY/CHARGING SYSTEM DIAGRAM

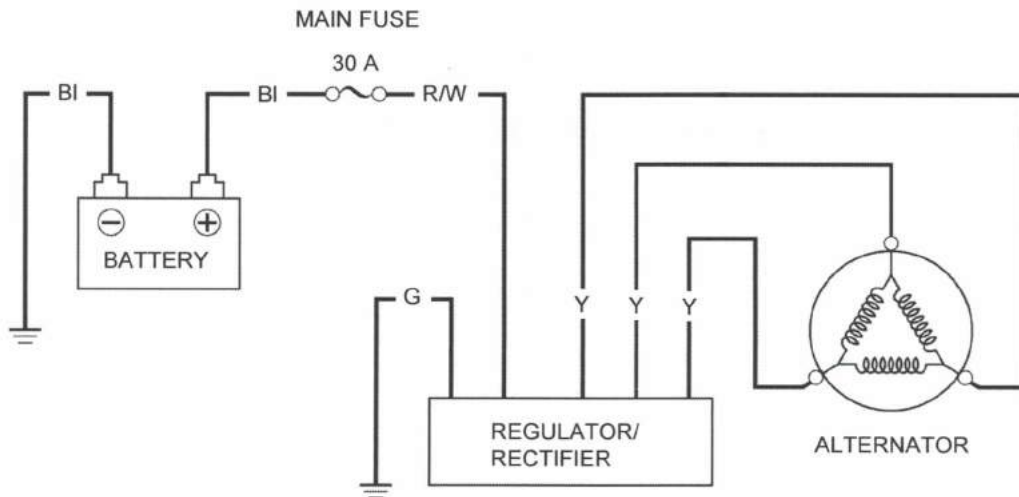

• Battery/charging system information, troubleshooting and inspection

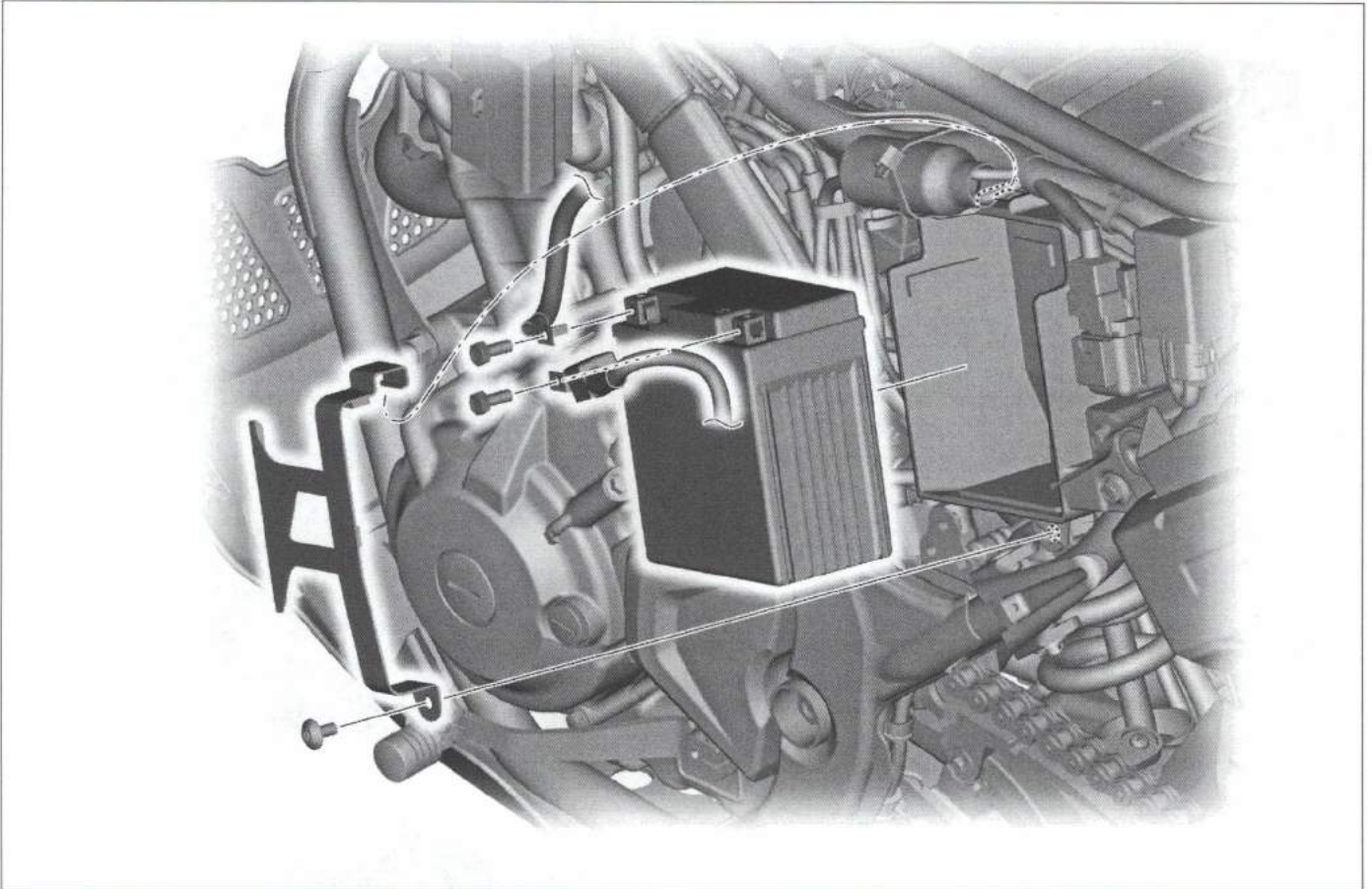
BATTERY

- Left fuel tank shroud →3-13
- Left side cover →3-8

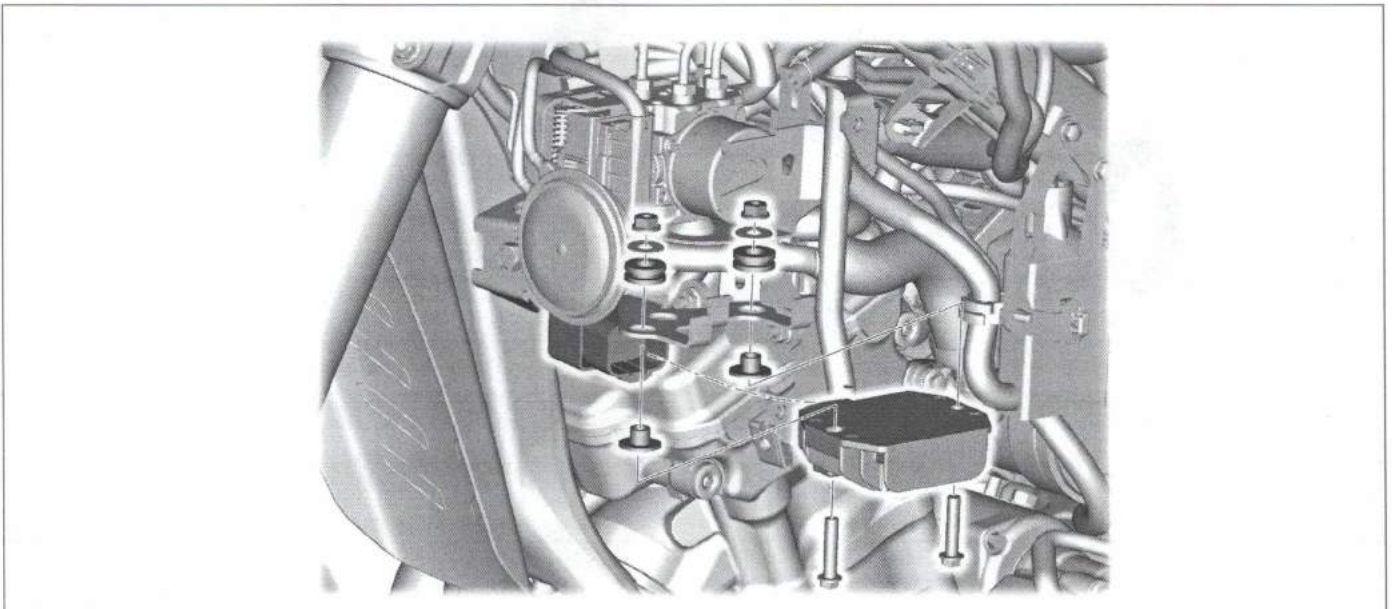
REGULATOR/RECTIFIER

- Radiator reserve tank →2-19



LIGHTING SYSTEM

Rally type:



8.5 N·m

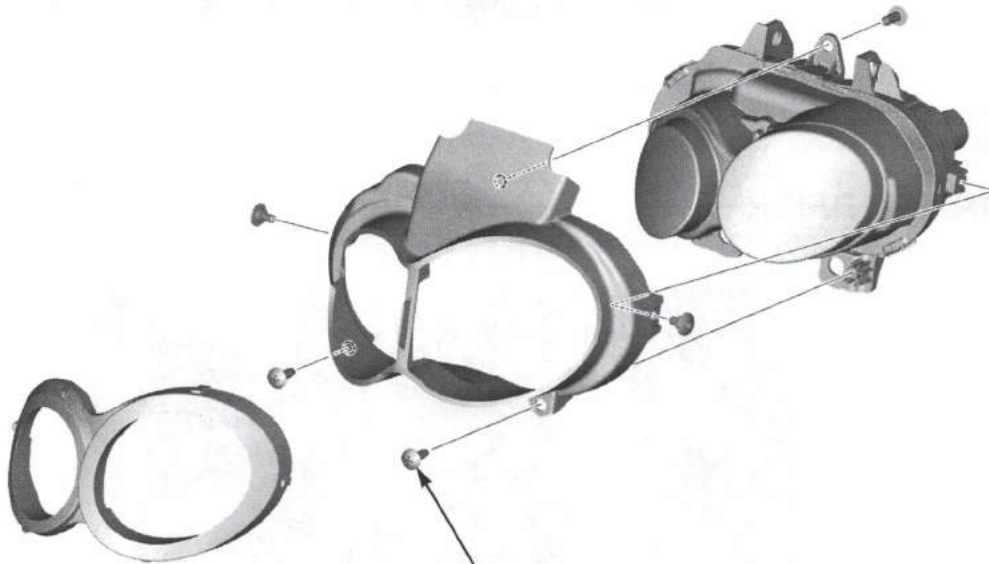
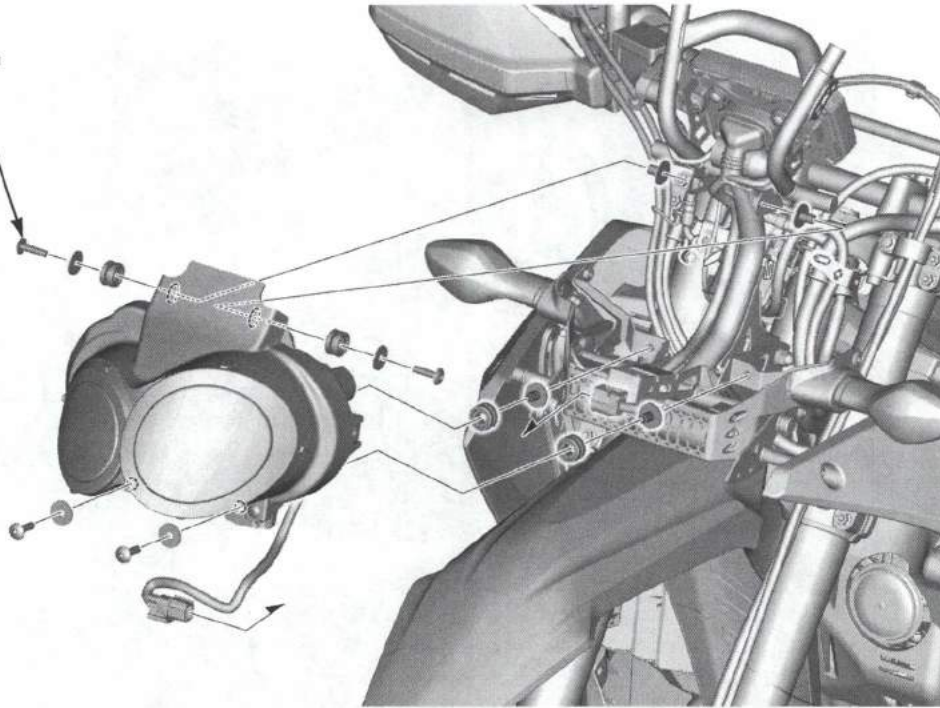

1.2 N·m

Rally type:

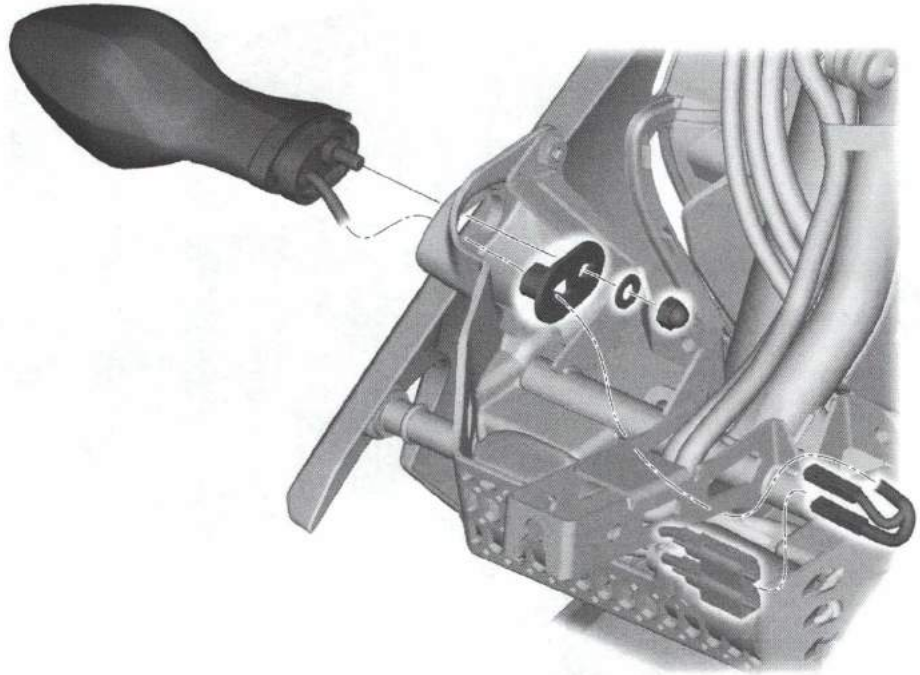

• Windscreen → 3-5



• Headlight → 4-52

Standard type:

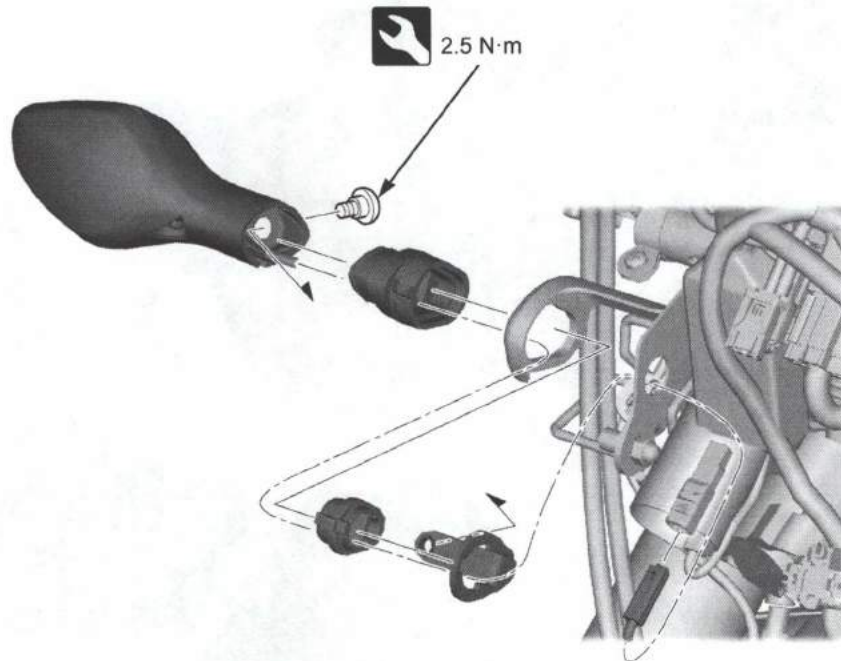

• Front visor → 3-6

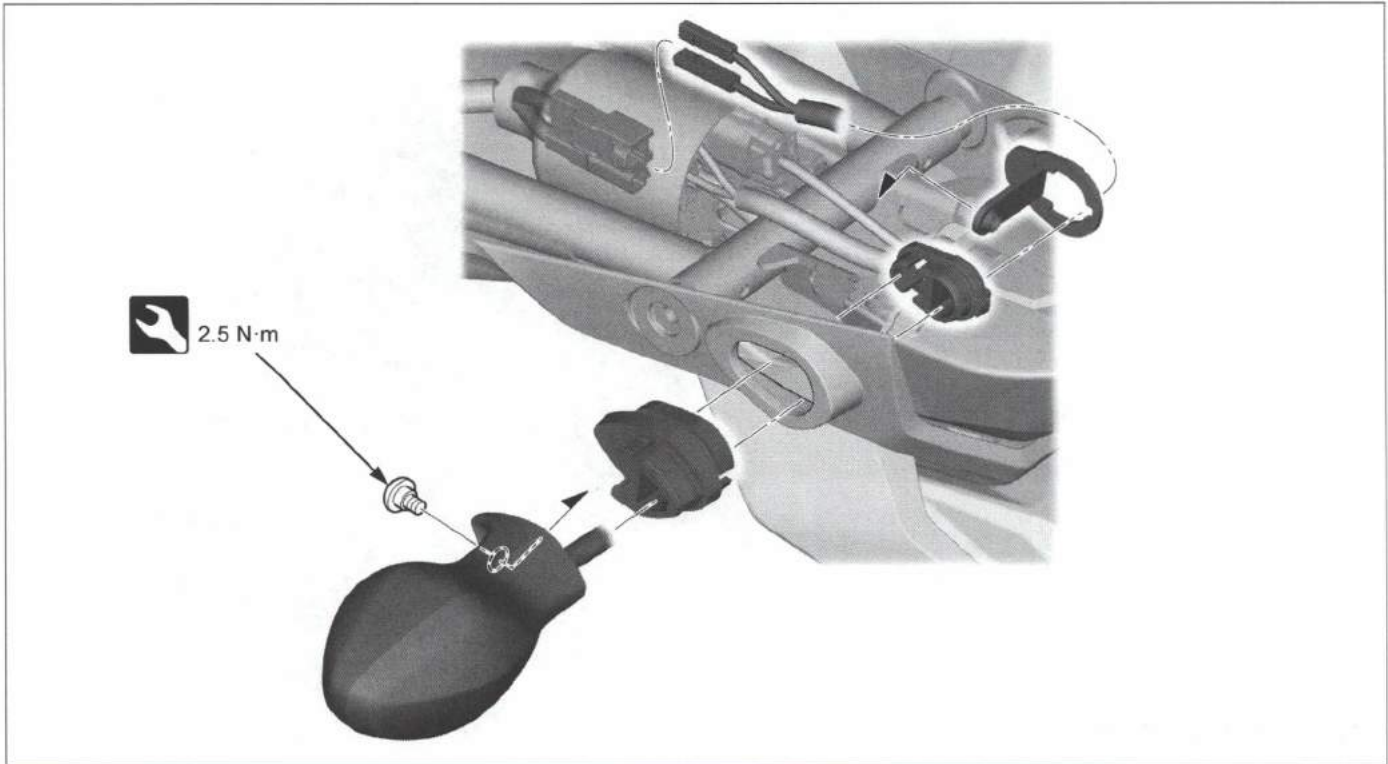

• Rear fender →3-8

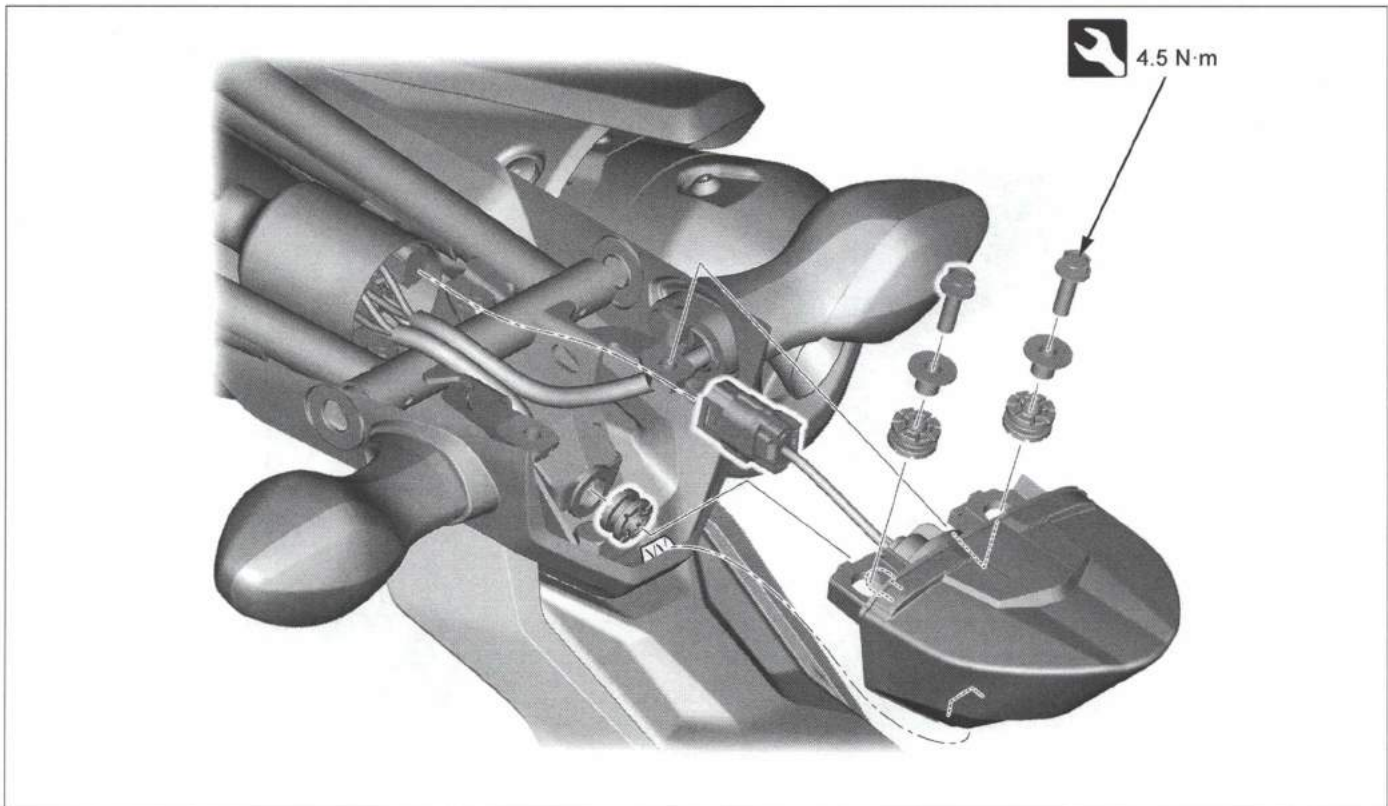

• Rear fender →3-8

BULB REPLACEMENT

Standard type:

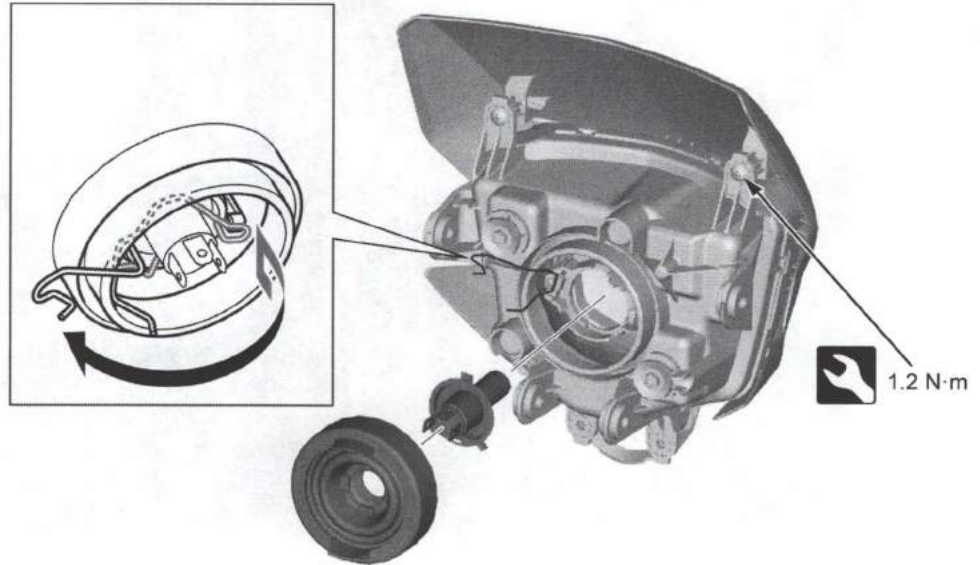

• Front visor → 3-6

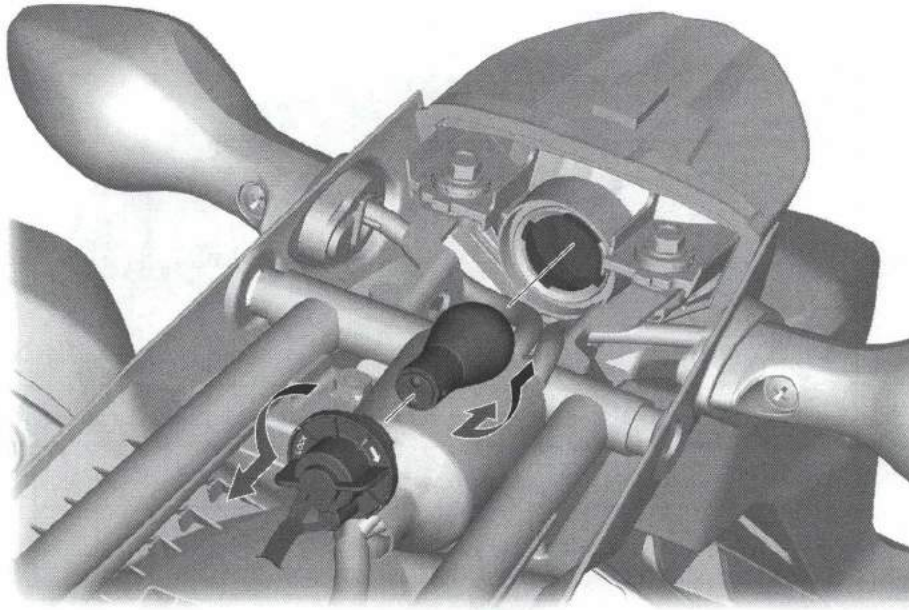

• Rear fender →3-8

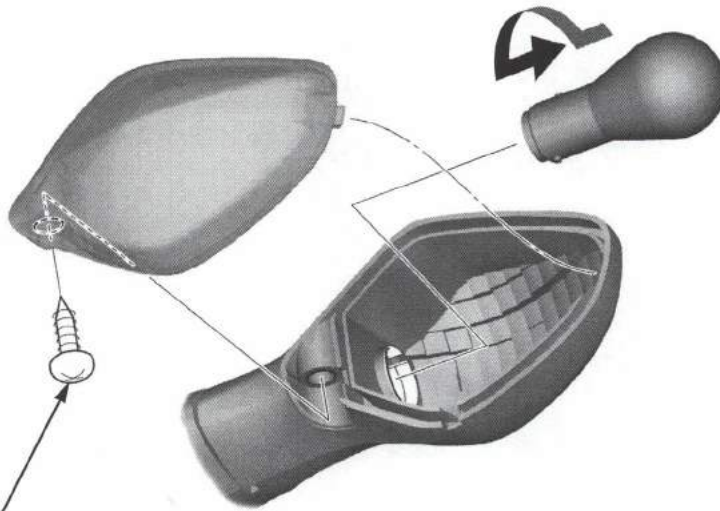

1.5 N·m

HEADLIGHT AIM

Rally type

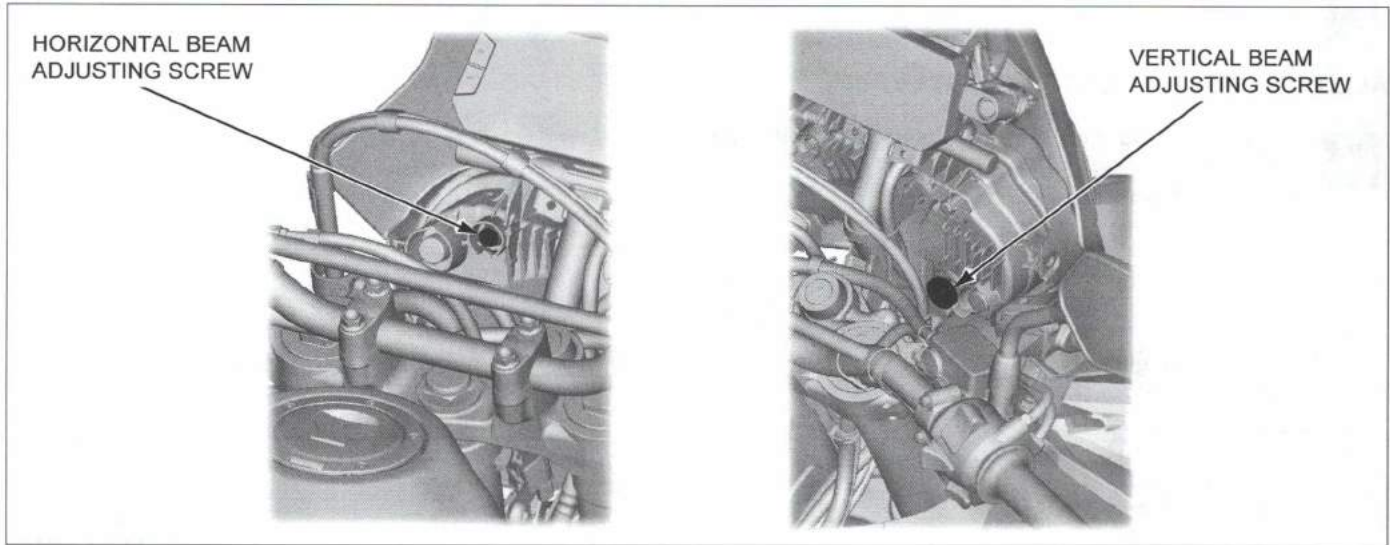

Standard bulb type

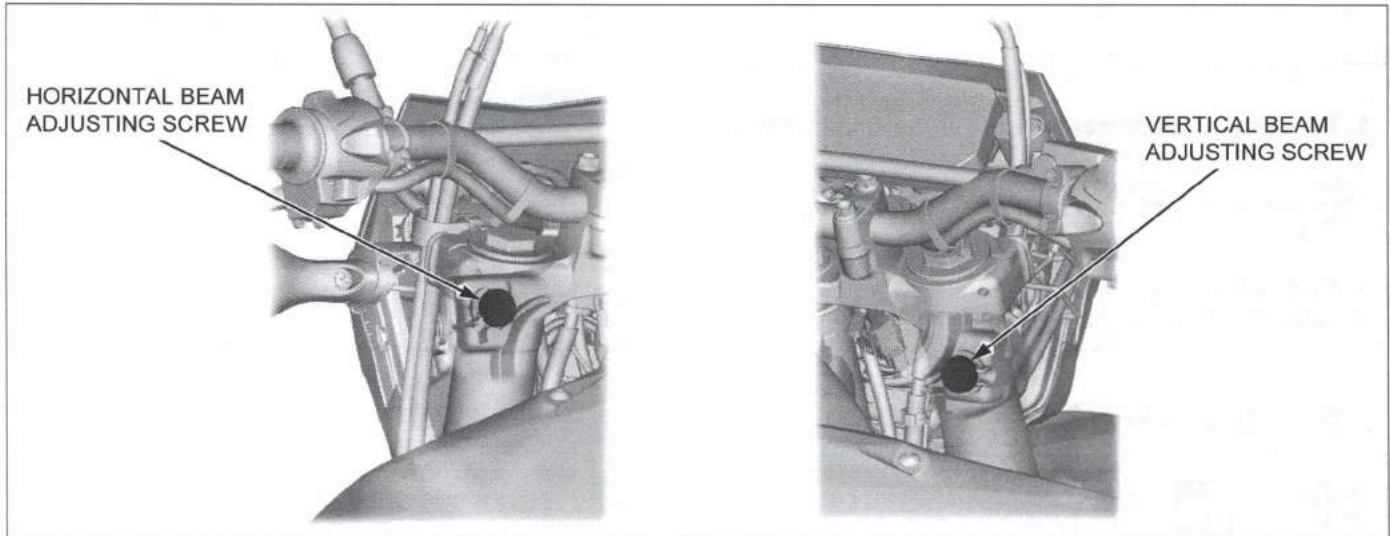



ELECTRICAL SYSTEM

TURN SIGNAL LIGHT TROUBLESHOOTING



- When all turn signal lights blink faster than usual, replace the turn signal light relay with a known good one, and recheck.

ALL TURN SIGNAL LIGHTS DO NOT LIGHT



- Loose or poor contacts of related terminal/connector
- Battery condition
- Burned fuse

1 Turn signal light relay 3P (Black) connector

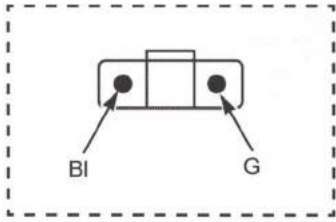

2 Left handlebar switch 14P connector

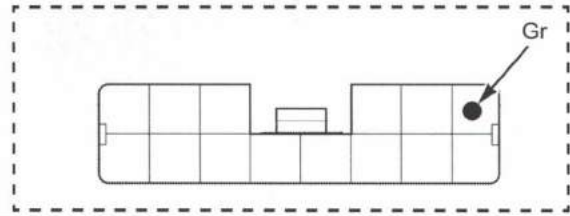

1. Turn Signal Light Relay Input Voltage Inspection



- Connection: BI (+) – G (-)
- Does the battery voltage exist?

Yes ▼

No ►

- Faulty BI or G wire

2. Turn Signal Light Relay Inspection

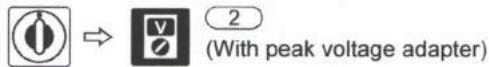

- Connection: Gr (+) – Ground (-)
(Connector connected)
- Peak voltage adapter: 07HGJ-0020100 or commercially available digital multimeter (impedance 10M)
- Battery voltage – Measured voltage = 1.5 V max.?

Yes ▼

No ►

- Replace the turn signal light relay with a new one, and recheck.

- Check for an open or short circuit in O or Lb wire.
- If there is no faulty circuit, replace the left handlebar switch with a new one →3-31, and recheck.

COMBINATION METER

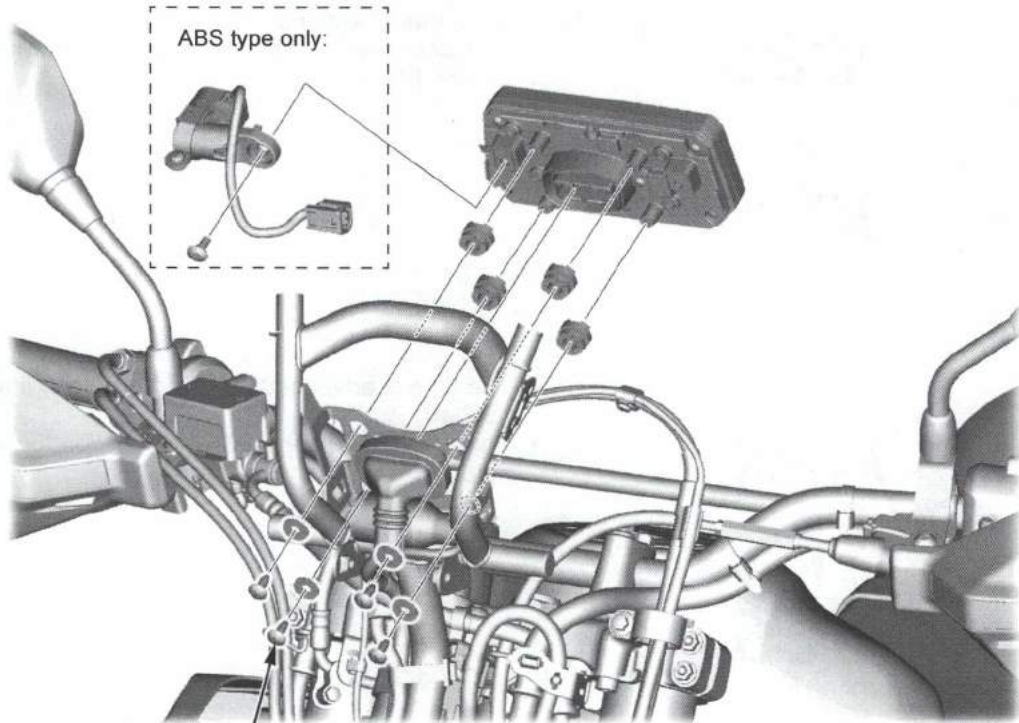

 1.0 N·m

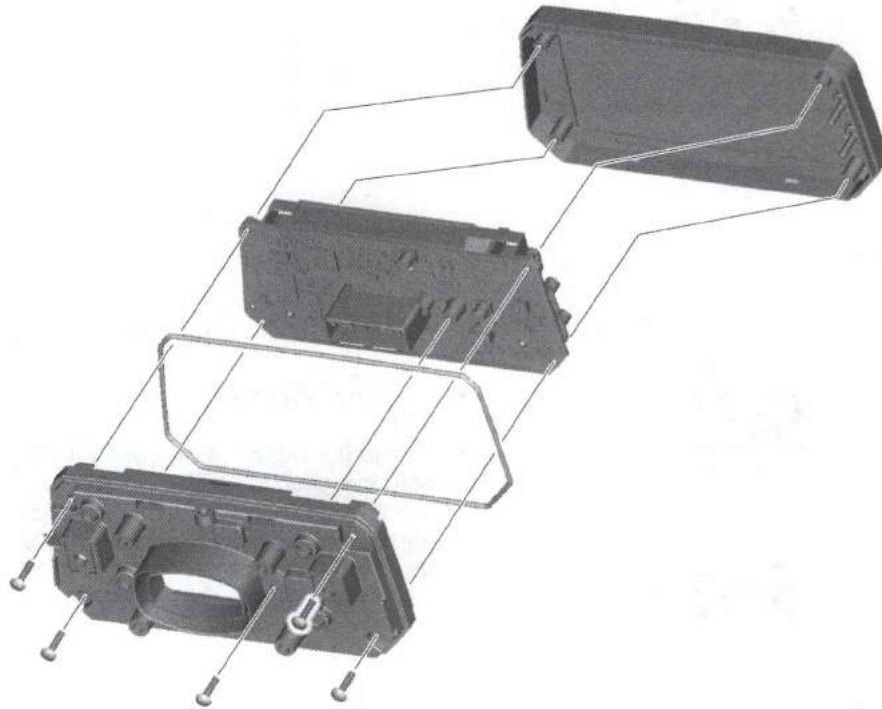

- Rally type: Headlight → 4-52
- Standard type: Front visor → 3-6



ELECTRICAL SYSTEM

CLOCK ADJUST

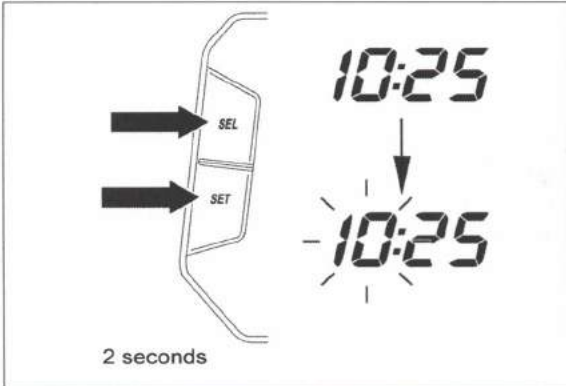

- Push and hold both the SEL button and SET button for more than 2 seconds.
- The clock will be set in the adjust mode with the hour display flashing.

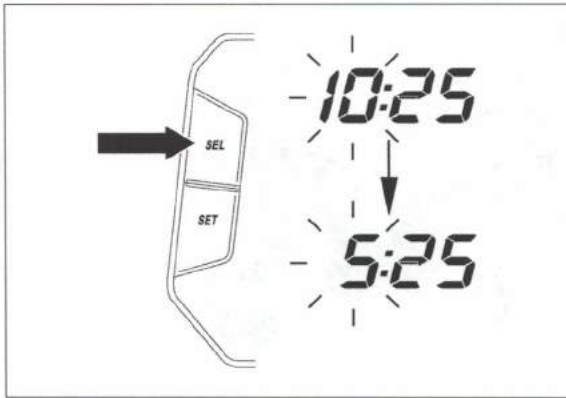

- The time is advanced by one hour, each time the button is pushed.
- The time advances fast when the button is pushed and held.

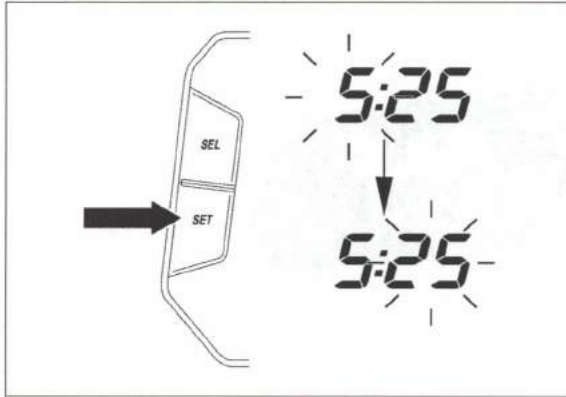



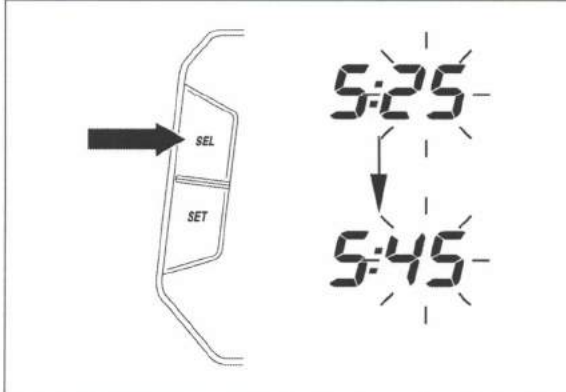

- Push the SET button.
- The minute display will start flashing.

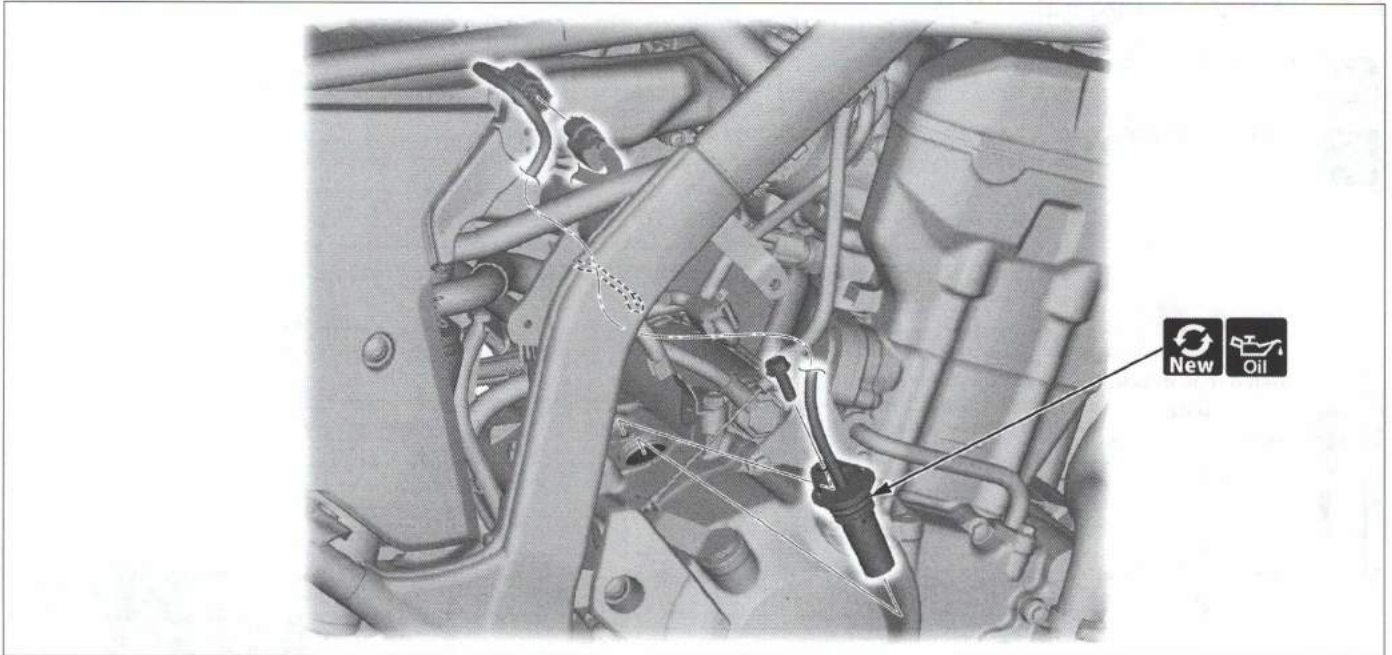

- The time advances by one minute, each time the button is pushed.
- The time advances fast when the button is pushed and held.
- To end the adjustment, push the SET button or turn the ignition switch to OFF.
- The display will stop flashing automatically and the adjustment will be cancelled if the button is not pushed for about 30 seconds.

VS SENSOR



-  • Fuel tank shroud →3-13
-  • EVAP system (AC type) →2-13
-  • VS sensor inspection

FUEL LEVEL SENSOR

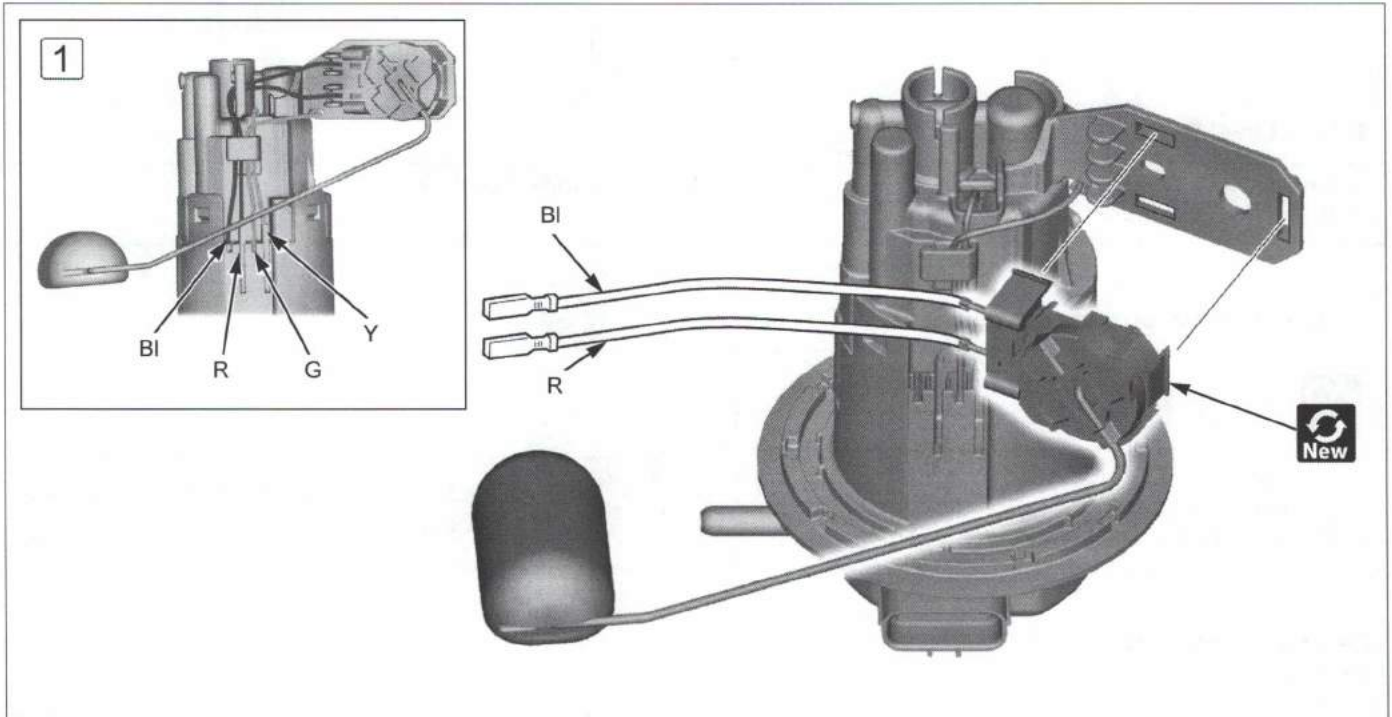

-  • Fuel pump unit →2-4
-  • ① Route the fuel level sensor wires to the guide and terminals properly.



ELECTRICAL SYSTEM

FUEL METER TROUBLESHOOTING

FUEL GAUGE FAILURE INDICATION



• Fuel pump unit →2-4



• Loose or poor contacts of related terminal/connector

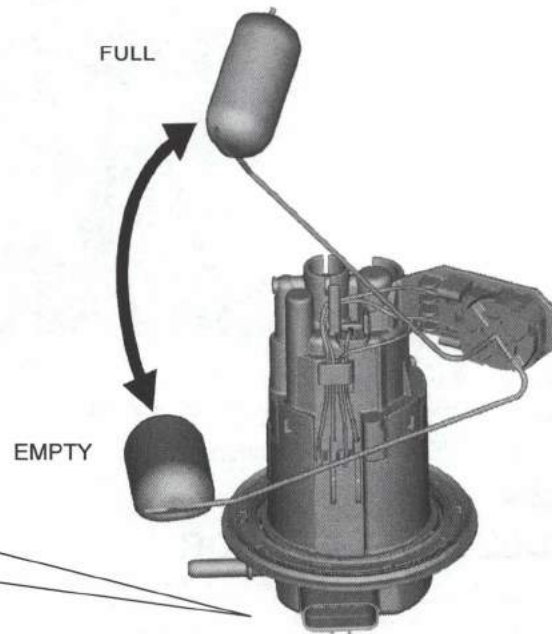
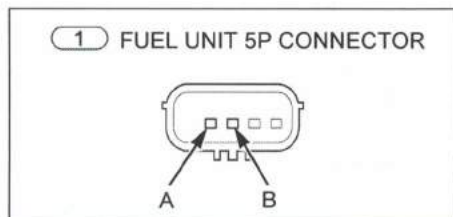
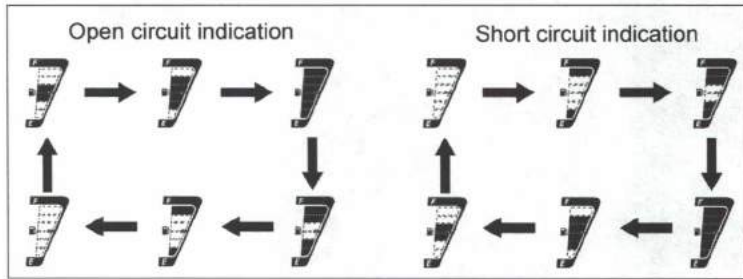

1. Fuel Level Sensor Circuit Inspection

- Check the Y, G wire.
- Is there no open or short circuit?

Yes ▼

No

- Faulty Y or G wire

2. Fuel Level Sensor Inspection



- Connection: A – B
- Standard: FULL 6 – 10 Ω, EMPTY 380 – 400 Ω
- Does the Standard resistance exist?

Yes ▼

No

- Replace the fuel level sensor with a new one →4-61, and recheck.

Replace the combination meter with a new one →4-59, and recheck.

ELECTRICAL COMPONENT

IGNITION SWITCH

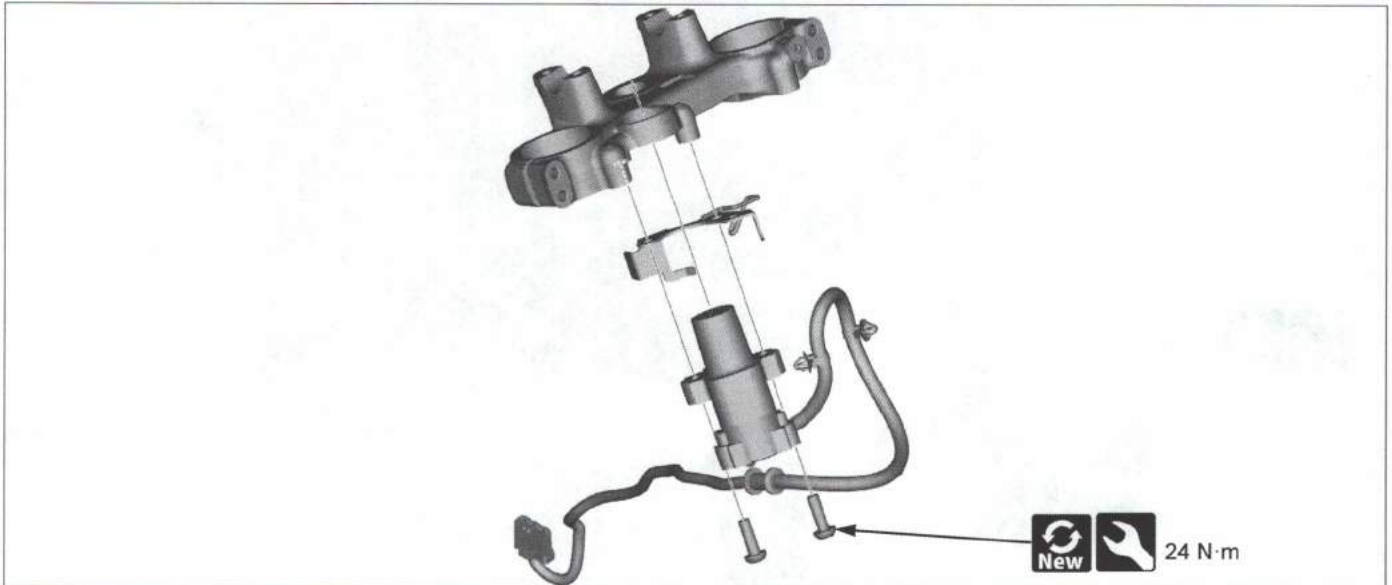

- Top bridge →3-32

IGNITION SWITCH INSPECTION



- Fuel tank shroud →3-13

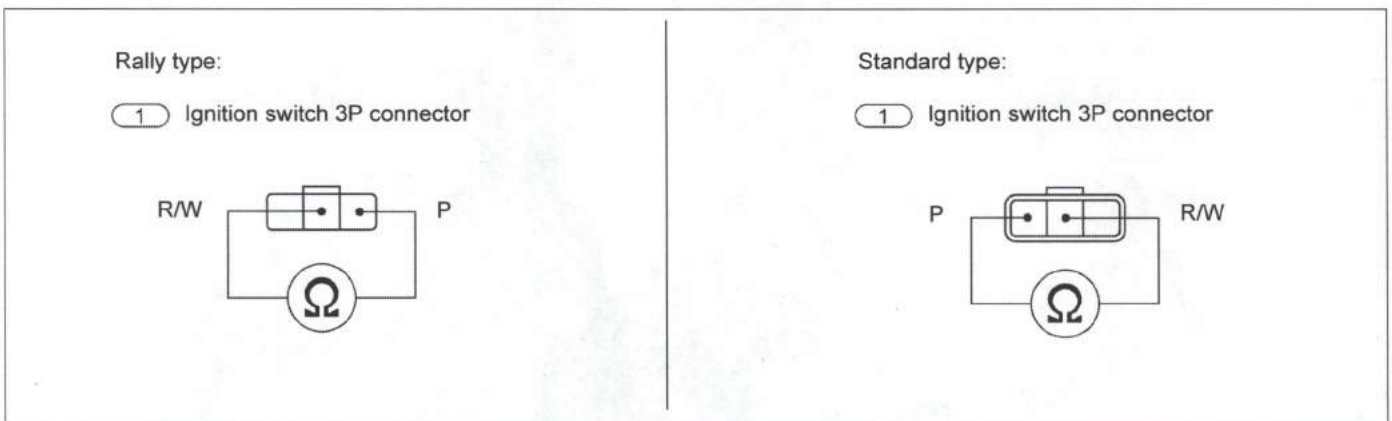

①

Check for continuity at the ignition switch 3P connector of the ignition switch side.

Connection: Red/white (+) – Pink (–)
Red/white (–) – Pink (+)

It is normal if there is continuity in one direction.

- It is faulty of the ignition switch if there is continuity in both directions.



SIDESTAND SWITCH

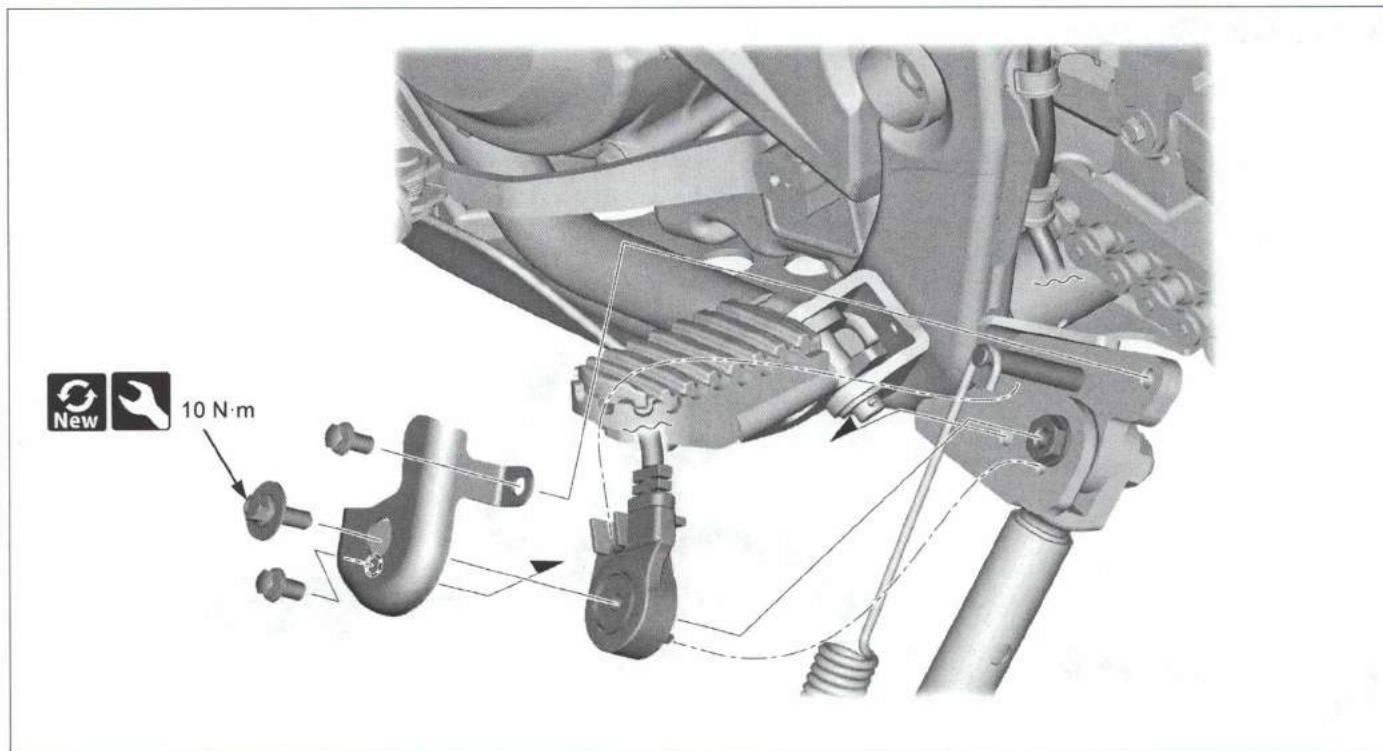

HORN

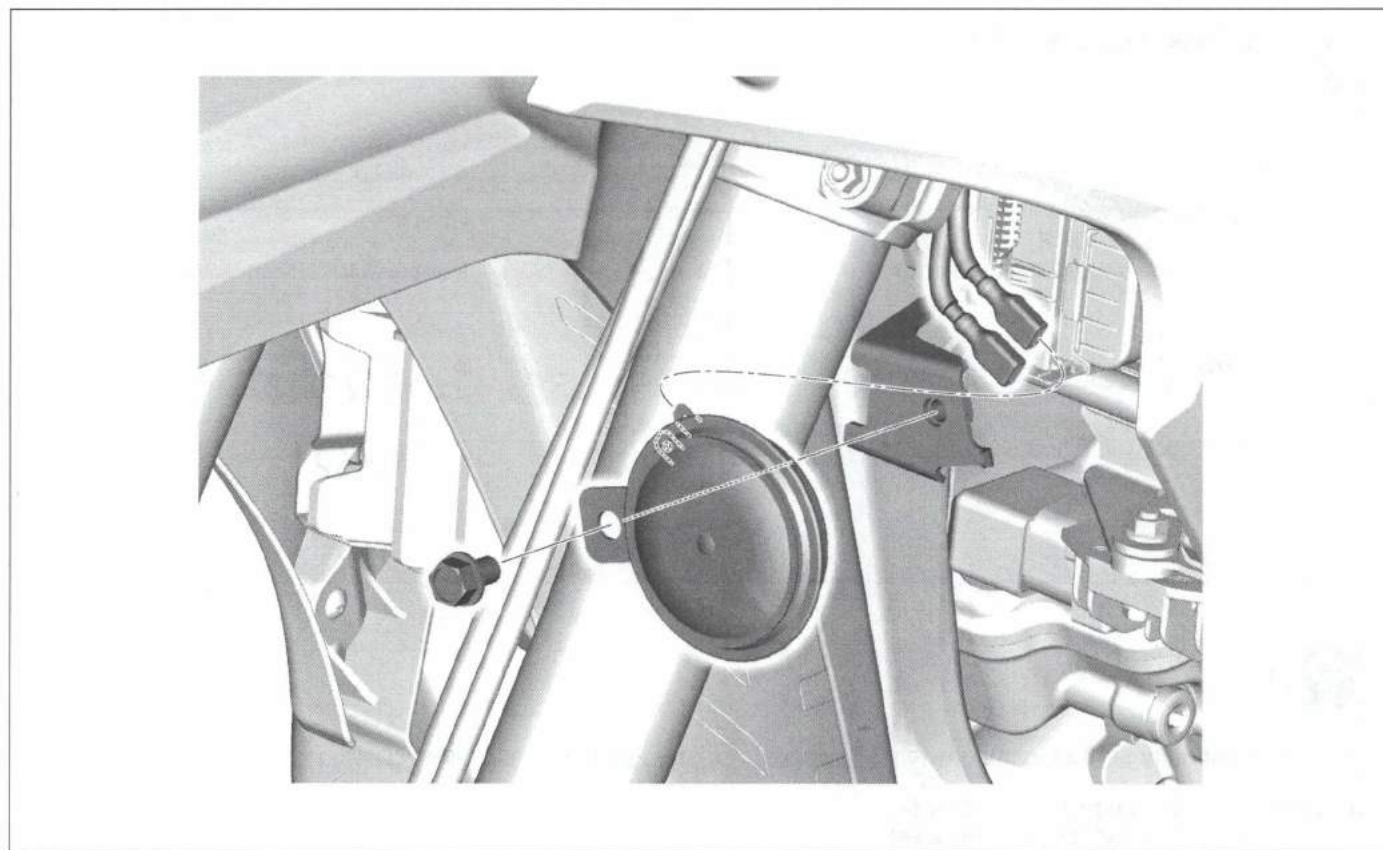

INDE

A Few Words About Safety	1-2	FUEL LINE	2-2
ABS	4-34	FUEL PUMP UNIT	2-4
AIR CLEANER	2-7	FUEL TANK	2-6
ALTERNATOR/STARTER CLUTCH	2-33	HANDLEBAR	3-31
BATTERY/CHARGING SYSTEM	4-50	HORN	4-64
BODY PANELS	3-2	How To Use This Manual	1-3
BRAKE FLUID REPLACEMENT	3-37	IGNITION SYSTEM	4-27
BULB REPLACEMENT	4-55	INJECTOR	2-11
CABLE & HARNESS ROUTING	1-22	LIGHTING SYSTEM	4-52
CLUTCH/GEARSHIFT LINKAGE	2-30	LUBRICATION SYSTEM	2-14
COMBINATION METER	4-59	MAINTENANCE SCHEDULE	1-68
COOLANT REPLACEMENT	2-17	MODEL IDENTIFICATION	1-5
COOLING SYSTEM	2-17	PGM-FI SYSTEM	4-2
CRANKCASE/CRANKSHAFT/BALANCER	2-35	RADIATOR/COOLING FAN	2-18
CYLINDER HEAD	2-22	REAR BRAKE	3-40
CYLINDER/PISTON	2-29	REAR SUSPENSION	3-36
ELECTRICAL COMPONENT	4-63	REAR WHEEL	3-34
ELECTRICAL STARTER	4-30	SECONDARY AIR SUPPLY SYSTEM	2-12
EMISSION CONTROL SYSTEMS	1-65	SIDESTAND	3-23
ENGINE OIL CHANGE	2-15	SPARK PLUG REPLACEMENT	4-28
ENGINE OIL FILTER CHANGE	2-15	SPECIAL TOOL LIST	1-21
ENGINE OIL LEVEL CHECK	2-14	SPECIFICATIONS	1-8
ENGINE OIL STRAINER SCREEN/OIL PUMP	2-16	STEERING STEM	3-32
ENGINE UNIT	2-40	THROTTLE BODY	2-8
EXHAUST PIPE/MUFFLER	3-24	TORQUE VALUE	1-16
FORK	3-28	TP SENSOR RESET PROCEDURE	2-10
FRONT BRAKE	3-37	TRANSMISSION	2-39
FRONT WHEEL	3-26	VALVE CLEARANCE	2-22
FUEL LEVEL SENSOR	4-61	WATER PUMP/THERMOSTAT	2-20



61K1T00

© Honda Motor Co., Ltd. Tokyo, Japan - All Rights Reserved
PRINTED IN U.S.A.